

Neousys Technology Inc.

POC-600 Series

User Manual

Revision 1.1

Table of Contents

Table of Contents	2
Legal Information	4
Contact Information	5
Declaration of Conformity	5
Copyright Notice	6
Safety Precautions	7
Service and Maintenance	8
ESD Precautions	8
About This Manual	9
1 Introduction	
1.1 Specification of POC-600	11
1.2 Specification of POC-610	13
1.3 Dimension	15
1.3.1 Superior View	15
1.3.2 Front Panel View	15
1.3.3 COM Port Panel View	16
1.3.4 Bottom View	16
1.4 POC-600 Series Mounting Options	17
1.4.1 DIN-Rail Mount Clip	17
1.4.2 Wall Mount (Optional)	18
1.4.3 Vertical Wall Mount (Optional)	19
2 System Overview	
2.1 Unpacking the System	20
2.2 POC-600 Series Front Panel	21
2.2.1 USB3.2 Gen1 Port	22
2.2.2 2.5G Ethernet Port	23
2.2.3 IEEE 802.3at Power over Ethernet Port (POC-600 only)	24
2.2.4 System Status LED	25
2.2.5 USB3.2 Gen2 Port	26
2.2.6 HDMI™ Port	27
2.2.7 3-Pin Terminal Block	28
2.3 POC-600 Series COM Port Panel	29
2.3.1 Power Button	30
2.3.2 Reset Button	30
2.3.3 COM Port (COM1)	31
2.3.4 COM Ports (COM2/ COM3/ COM4)	32
2.3.5 3.5mm Microphone-in/ Speaker-out Jack	33
2.3.6 SMA Antennae Opening	33
2.4 POC-600 Series Internal I/O	34
2.4.1 SO-DIMM Memory Socket	34
2.4.2 M.2 2280 M Key	35
2.5 MeziO® Interface	37
2.5.1 MeziO® Interface Pin Definition	38
2.5.2 MeziO® Modules for POC-600 Series	39
3 System Installation	
3.1 Disassembling the System Enclosure	41
3.2 Installing Internal Components	44
3.2.1 SO-DIMM Installation	44
3.2.2 M.2 2280 M Key Module Installation	46
3.2.3 MeziO® Module Installation	48
3.3 Installing the System Enclosure	51
3.4 DIN Rail Installation	53

3.5	Wall Mount Installation (Optional Accessory)	55
3.5.1	Standard Wall Mount (Optional Accessory)	55
3.5.2	Vertical Wall Mount (Optional Accessory)	57
3.6	Powering On the System	58
3.6.1	Powering On Using the Power Button.....	58
3.6.2	Powering On Using An External Non-Latched Switch.....	59
3.6.3	Powering On Using Wake-on-LAN.....	60
4	BIOS Settings	
4.1	COM1 Port Configuration	63
4.1.1	COM Port High Speed Mode	64
4.1.2	COM Port Slew Rate.....	65
4.2	COM2/ 3/ 4 Port Configuration	66
4.3	TPM Availability	67
4.4	C-States	68
4.5	Power over Ethernet (POE-600 Only)	69
4.6	Wake-on-LAN	71
4.7	Power On after Power Failure	72
4.8	Boot Menu	73
4.9	Position New Boot Device	75
4.10	Watchdog Timer	76
5	OS Support and Driver Installation	
5.1	Operating System Compatibility	77
5.2	Driver Installation	78
5.3	Driver for Watchdog Timer and DIO	78
Appendix A Using WDT & DIO		
WDT and DIO Library Installation	80	
WDT Function Reference	82	
InitWDT	82	
SetWDT	82	
StartWDT.....	83	
ResetWDT.....	83	
StopWDT	83	
DIO Functions	84	
InitDIO	84	
DReadLine	84	
DReadPort	84	
DWriteLine.....	85	
DWritePort.....	85	
Appendix B PoE On/ Off Control	86	
PoE On/ Off Control Function Reference	86	
GetStatusPoEPort	86	
EnablePoEPort.....	87	
DisablePoEPort.....	88	

Legal Information

All Neosys Technology Inc. products shall be subject to the latest Standard Warranty Policy

Neosys Technology Inc. may modify, update or upgrade the software, firmware or any accompanying user documentation without any prior notice. Neosys Technology Inc. will provide access to these new software, firmware or documentation releases from download sections of our website or through our service partners.

Before installing any software, applications or components provided by a third party, customer should ensure that they are compatible and interoperable with Neosys Technology Inc. product by checking in advance with Neosys Technology Inc. Customer is solely responsible for ensuring the compatibility and interoperability of the third party's products. Customer is further solely responsible for ensuring its systems, software, and data are adequately backed up as a precaution against possible failures, alternation, or loss.

For questions in regards to hardware/ software compatibility, customers should contact Neosys Technology Inc. sales representative or technical support.

To the extent permitted by applicable laws, Neosys Technology Inc. shall NOT be responsible for any interoperability or compatibility issues that may arise when (1) products, software, or options not certified and supported; (2) configurations not certified and supported are used; (3) parts intended for one system is installed in another system of different make or model.

Contact Information

Headquarters
(Taipei, Taiwan) **Neosys Technology Inc.**
15F, No.868-3, Zhongzheng Rd., Zhonghe Dist., New Taipei City, 23586, Taiwan
Tel: +886-2-2223-6182 Fax: +886-2-2223-6183 [Email](#), [Website](#)

Americas
(Illinois, USA) **Neosys Technology America Inc.**
3384 Commercial Avenue, Northbrook, IL 60062, USA
Tel: +1-847-656-3298 [Email](#), [Website](#)

China **Neosys Technology (China) Ltd.**
Room 612, Building 32, Guiping Road 680, Shanghai
Tel: +86-2161155366 [Email](#), [Website](#)

Declaration of Conformity

FCC This equipment has been tested and found to comply with the limits for a Class A digital device, pursuant to part 15 of the FCC Rules. These limits are designed to provide reasonable protection against harmful interference when the equipment is operated in a commercial environment. This equipment generates, uses, and can radiate radio frequency energy and, if not installed and used in accordance with the instruction manual, may cause harmful interference to radio communications. Operation of this equipment in a residential area is likely to cause harmful interference in which case the user will be required to correct the interference at own expense.

CE The product(s) described in this manual complies with all applicable European Union (CE) directives if it has a CE marking. For computer systems to remain CE compliant, only CE-compliant parts may be used. Maintaining CE compliance also requires proper cable and cabling techniques.

Copyright Notice

All rights reserved. This publication may not be reproduced, transmitted, transcribed, stored in a retrieval system, or translated into any language or computer language, in any form or by any means, electronic, mechanical, magnetic, optical, chemical, manual or otherwise, without the prior written consent of Neosys Technology, Inc.

Disclaimer

This manual is intended to be used as an informative guide only and is subject to change without prior notice. It does not represent commitment from Neosys Technology Inc. Neosys Technology Inc. shall not be liable for any direct, indirect, special, incidental, or consequential damages arising from the use of the product or documentation, nor for any infringement on third party rights.

Patents and Trademarks

Neosys, the Neosys logo, Expansion Cassette, MezIO™ are registered patents and trademarks of Neosys Technology, Inc.

Windows is a registered trademark of Microsoft Corporation.

Intel®, Core™ are registered trademarks of Intel Corporation

NVIDIA®, GeForce® are registered trademarks of NVIDIA Corporation

All other names, brands, products or services are trademarks or registered trademarks of their respective owners.

Safety Precautions

- Read these instructions carefully before you install, operate, or transport the system.
- Install the system or DIN rail associated with, at a sturdy location
- Install the power socket outlet near the system where it is easily accessible
- Secure each system module(s) using its retaining screws
- Place power cords and other connection cables away from foot traffic. Do not place items over power cords and make sure they do not rest against data cables
- Shutdown, disconnect all cables from the system and ground yourself before touching internal modules
- Ensure that the correct power range is being used before powering the device
- Should a module fail, arrange for a replacement as soon as possible to minimize down-time
- By means of a power cord connected to a socket-outlet with earthing connection
- This product is intended to be supplied by a Listed Power Adapter or DC power source, rated 8-35Vdc, 16A, Tma 70 degree C and 5000m altitude during operation. If further assistance is required, please contact Neosys Technology
- If the system is not going to be used for a long time, disconnect it from mains (power socket) to avoid transient over-voltage

Service and Maintenance

- ONLY qualified personnel should service the system
- Shutdown the system, disconnect the power cord and all other connections before servicing the system
- When replacing/ installing additional components (expansion card, memory module, etc.), insert them as gently as possible while assuring proper connector engagement

ESD Precautions

- Handle add-on module, motherboard by their retention screws or the module's frame/ heat sink. Avoid touching the PCB circuit board or add-on module connector pins
- Use a grounded wrist strap and an anti-static work pad to discharge static electricity when installing or maintaining the system
- Avoid dust, debris, carpets, plastic, vinyl and styrofoam in your work area.
- Do not remove any module or component from its anti-static bag before installation

About This Manual

This manual introduces and demonstrates installation procedures of Neosys POC-600 series systems.

Revision History

Version	Date	Description
1.0	Nov. 2025	Initial release
1.1	Feb. 2026	Updated specifications (audio port)

1 Introduction

POC-600 is Neosys' new ultra-compact fanless embedded computer based on Intel® Atom® x7425E processor. With four efficient cores operating at only 12W TDP and support for up to 16 GB DDR5 memory, it delivers up to 1.5x CPU performance improvement and higher memory bandwidth compared to previous Atom® platforms, making it a reliable solution for next-generation industrial edge deployments.

Despite its small form factor, POC-600 delivers comprehensive connectivity. It integrates three 2.5GbE ports powered by Intel® I226-IT controllers, with an option for two PoE+ ports to power cameras or sensors. The system also provides dual HDMI™ 1.4b outputs supporting 3840 x 2160 resolution, four screw-lock USB3.2 ports for reliable high-speed connections, as well as versatile serial communication with one software-programmable RS-232/422/485 and additional RS-232 or RS-422/485 ports. For storage, POC-600 supports one M.2 2280 SATA device and Neosys' proprietary MezIO® interface for adding application-specific functions such as isolated DIO, ignition control, or wireless modules.

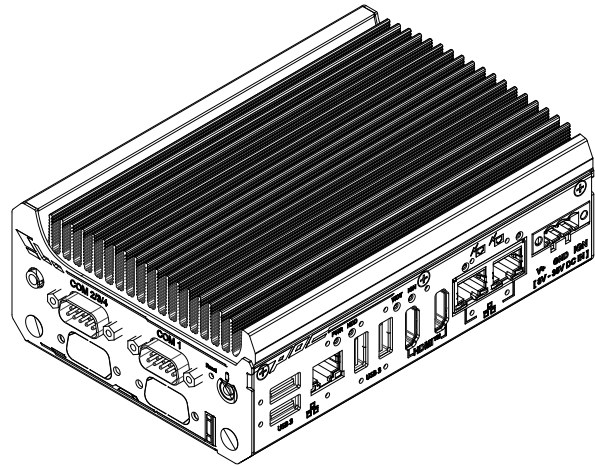

With its balance of performance, low power consumption, and robust I/O capabilities, POC-600 is designed for a wide range of industrial applications. It is ideal for machine vision systems requiring multiple high-speed camera connections and smart transportation that demands reliable PoE+ networking. Sharing the same compact footprint as POC-400 and POC-300, POC-600 allows seamless system upgrades and supports DIN-rail mounting for easy and secure installation in industrial control cabinets or confined spaces, enabling next-generation industrial automation and intelligent edge solutions.

1.1 Specification of POC-600

System Core	
Processor	Intel® Atom® x7425E processor with 4 E-Cores (4C/4T, 1.5/ 3.4GHz, 12W TDP)
Graphics	Integrated Intel® UHD Graphics with 24EUs
Memory	Up to 16GB DDR5-4800 SDRAM (one SODIMM socket)
TPM	Supports dTPM 2.0
Panel I/O Interface	
Ethernet	3x 2.5GBASE-T Ethernet ports by Intel® I226-IT GbE controllers
PoE+	IEEE 802.3at PoE+ on port #2 and #3, 50W total power budget
Video Port	2x HDMI™ 1.4b, supporting 3840 x 2160
Serial Port	1x software-programmable RS-232/422/485 ports (COM1) 3x 3-wire RS-232 ports (COM2/3/4) or 1x RS-422/485 port (COM2)
USB	2x USB3.2 Gen1 with screw-lock 2x USB3.2 Gen2 with screw-lock
Audio	1x 3.5mm jack for microphone-in/ speaker-out
Storage Interface	
M.2 M key	1x M.2 2280 SATA interface
Expandable I/O	
1x MeziO® expansion port for Neosys MeziO® modules	
Power Supply	
DC Input	1x 3-pin pluggable terminal block for 8-35V DC input
Mechanical	
Dimension	56 mm (W) x 108 mm (D) x 153 mm (H)
Weight	0.98kg
Mounting	DIN-rail mount (standard) or Wall-mount (optional)
Environmental	
Operating Temperature	-25°C to 70°C */**
Storage Temperature	-40°C to 85°C*/**
Humidity	10% to 90% , non-condensing
Vibration	MIL-STD-810H, Method 514.8, Category 4
Shock	MIL-STD-810H, Method 516.8, Procedure I
EMC	CE/FCC Class A, according to EN 55032 & EN 55035

** The 100% CPU/GPU loading for high temperature test is applied using Passmark® BurnInTest™ v10.2. For detail testing criteria, please contact Neosys Technology*

*** For sub-zero operating temperature, a wide temperature HDD drive or Solid State Disk (SSD) is required.*

1.2 Specification of POC-610

System Core	
Processor	Intel® Atom® x7425E processor with 4 E-Cores (4C/4T, 1.5/ 3.4GHz, 12W TDP)
Graphics	Integrated Intel® UHD Graphics with 24EUs
Memory	Up to 16GB DDR5-4800 SDRAM (one SODIMM socket)
TPM	Supports dTPM 2.0
Panel I/O Interface	
Ethernet	3x 2.5GBASE-T Ethernet ports by Intel® I226-IT GbE controllers
Video Port	2x HDMI™ 1.4b, supporting 3840 x 2160
Serial Port	1x software-programmable RS-232/422/485 ports (COM1) 3x 3-wire RS-232 ports (COM2/3/4) or 1x RS-422/485 port (COM2)
USB	2x USB3.2 Gen1 with screw-lock 2x USB3.2 Gen2 with screw-lock
Audio	1x 3.5mm jack for microphone-in/ speaker-out
Storage Interface	
M.2 M key	1x M.2 2280 SATA interface
Expandable I/O	
1x MeziO® expansion port for Neousys MeziO® modules	
Power Supply	
DC Input	1x 3-pin pluggable terminal block for 8-35V DC input
Mechanical	
Dimension	56 mm (W) x 108 mm (D) x 153 mm (H)
Weight	0.98kg
Mounting	DIN-rail mount (standard) or Wall-mount (optional)
Environmental	
Operating Temperature	-25°C to 70°C */**
Storage Temperature	-40°C to 85°C*/**
Humidity	10% to 90% , non-condensing
Vibration	MIL-STD-810H, Method 514.8, Category 4
Shock	MIL-STD-810H, Method 516.8, Procedure I
EMC	CE/FCC Class A, according to EN 55032 & EN 55035

** The 100% CPU/GPU loading for high temperature test is applied using Passmark® BurnInTest™ v10.2. For detail testing criteria, please contact Neosys Technology*

*** For sub-zero operating temperature, a wide temperature HDD drive or Solid State Disk (SSD) is required.*

1.3 Dimension

1.3.1 Superior View

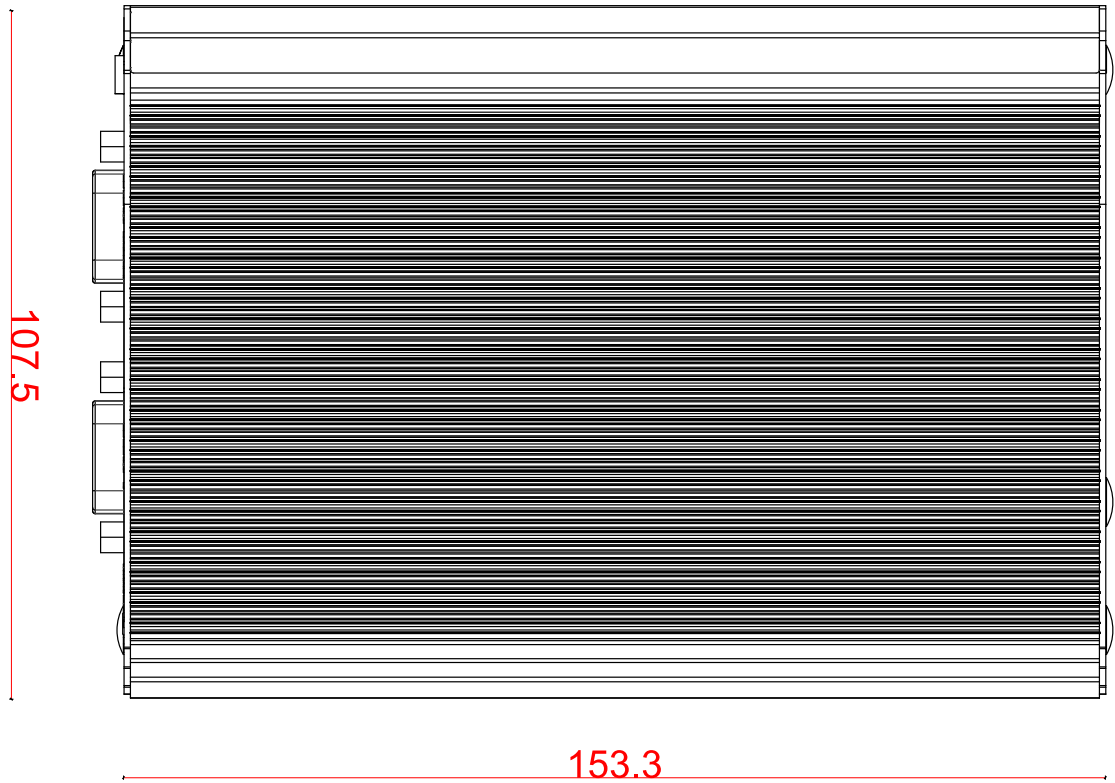

1.3.2 Front Panel View

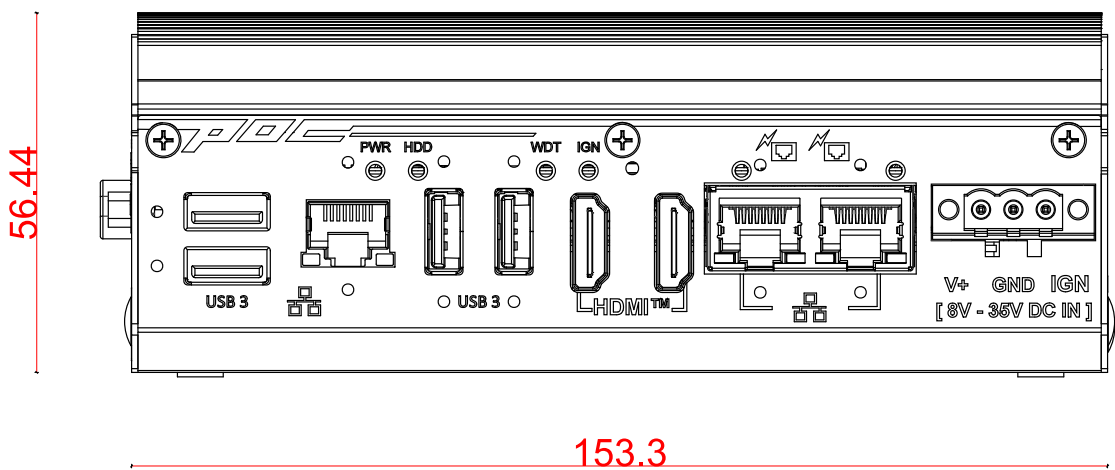

1.3.3 COM Port Panel View

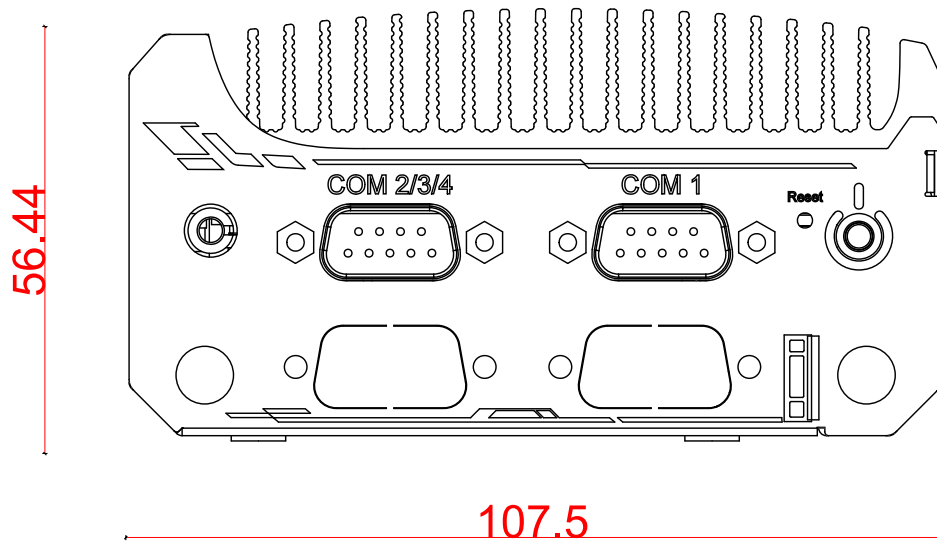

1.3.4 Bottom View

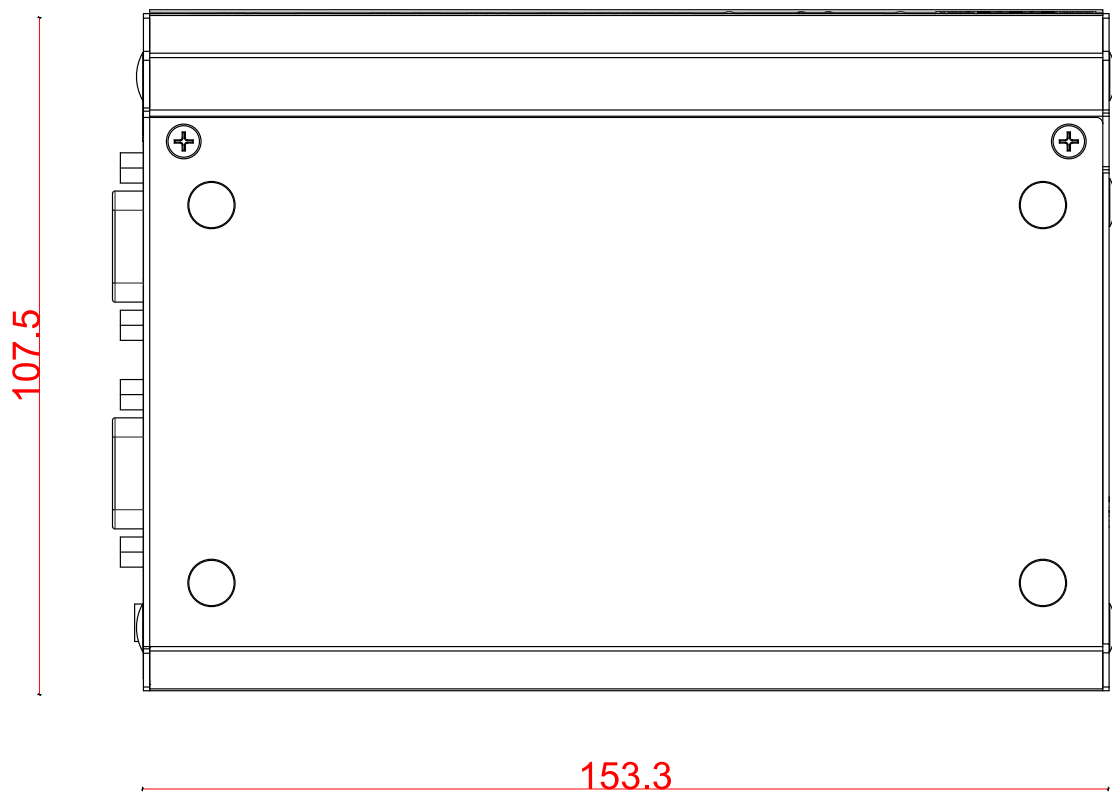

1.4 POC-600 Series Mounting Options

The system comes with various mounting options such as DIN-rail and wall-mount bracket. DIN-rail mount clip is shipped with POC-600 series as standard mounting option, and an optional wall mount (purchased separately).

1.4.1 DIN-Rail Mount Clip

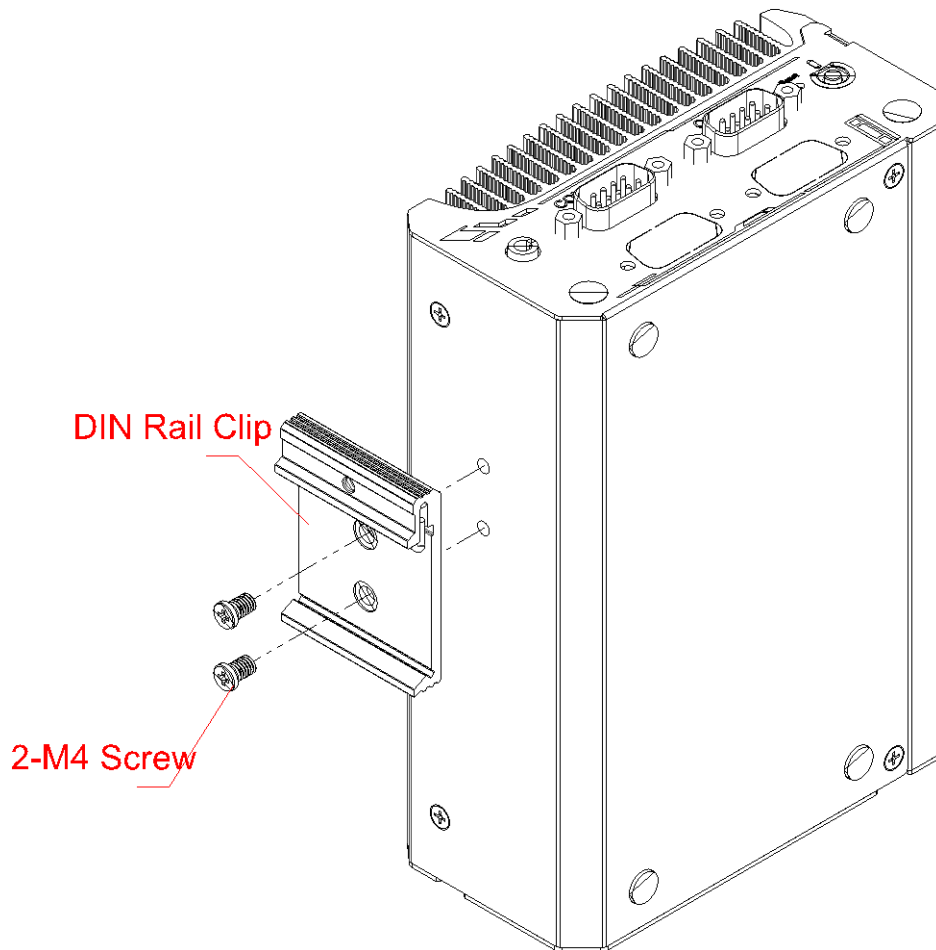

1.4.2 Wall Mount (Optional)

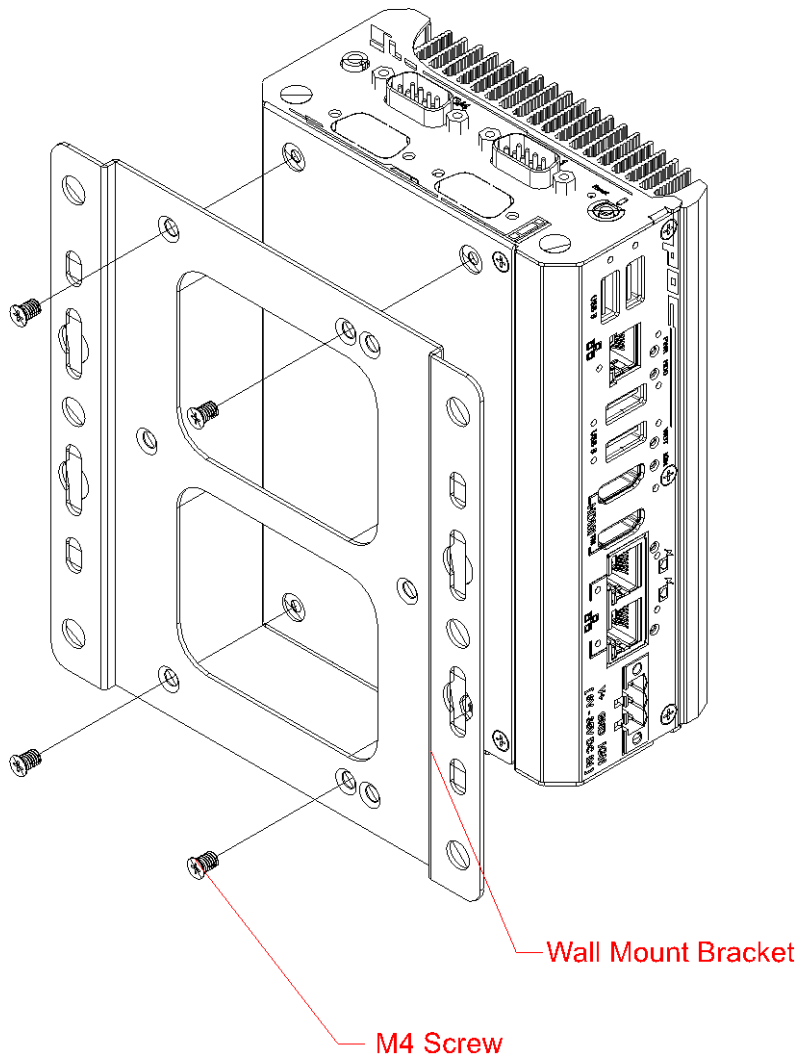

1.4.3 Vertical Wall Mount (Optional)

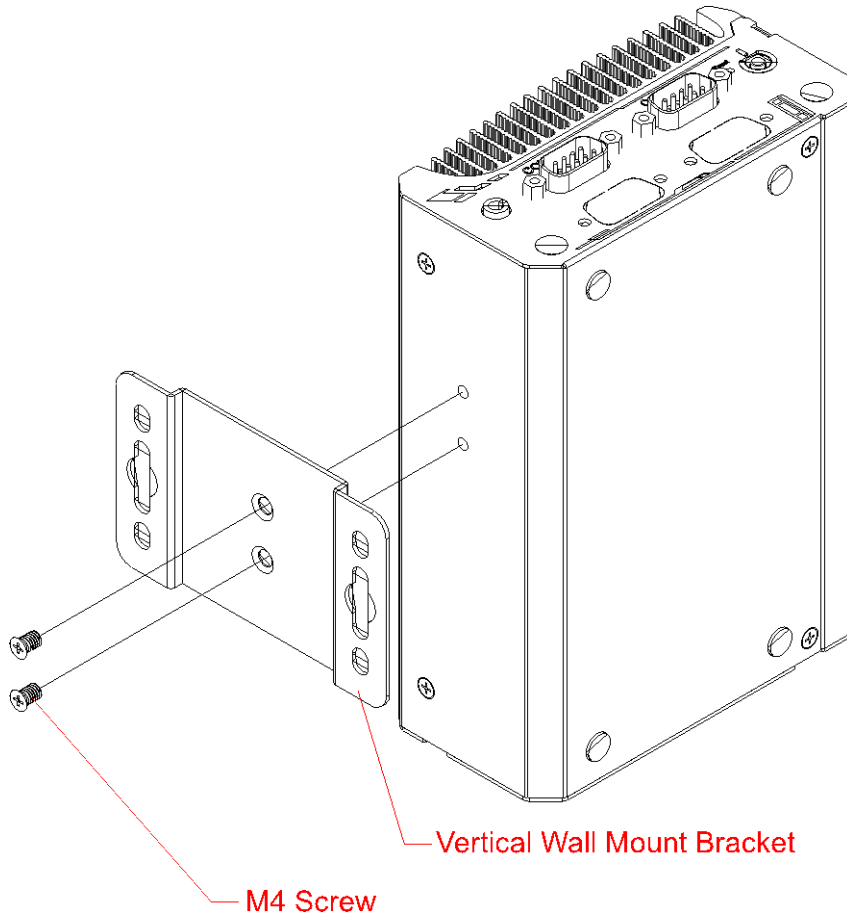

2 System Overview

Upon receiving and unpacking your POC-600 series, please check immediately if the package contains all the items listed in the following table. If any item(s) are missing or damaged, please contact your local dealer or Neosys Technology.

2.1 Unpacking the System

Item	Description	Qty
1	POC-600 ultra-compact fanless computer (Please verify additionally purchased accessories such as memory module, M.2 SSD, MezIO [®] , etc.)	1
2	3-pin pluggable terminal block	1
3	DIN-Rail Mount Clip	1
4	Screw package	1

2.2 POC-600 Series Front Panel

The front panel of POC-600 series features rich I/O ports, it has three 2.5G Ethernet ports (two are PoE+ ports for POC-600), two USB3.2 Gen1 ports, two USB3.2 Gen2 ports, two DisplayPort ports for video output, CMOS reset button and 3-pin terminal block for DC input.

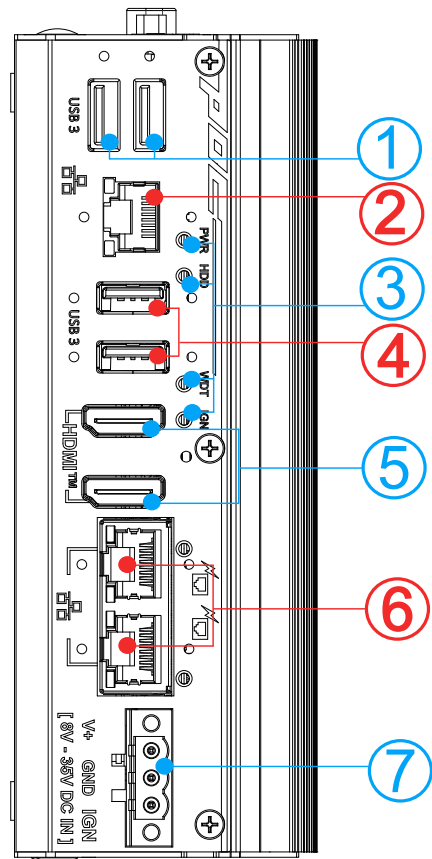

No.	Item	Description
1	USB 3.2 Gen 1 port	The USB 3.2 Gen1 ports support up to 5Gbit/s data transfer bandwidth and are backward compatible with USB 2.0/ 1.1/ 1.0.
2	2.5G Ethernet port	The Ethernet port offers up to 2.5Gb/s transfer bandwidth
3	System status LED	Four system LEDs, Power (PWR), Hard Disk Drive (HDD), Watchdog Timer (WDT) and Ignition control (IGN)
4	USB 3.2 Gen 2 port	USB3.2 Gen 2 port (SuperSpeed+) offers up to 10Gbps, twice the bandwidth over existing SuperSpeed USB3.2 Gen. 1 connection. It is also backwards compatible with USB3.0 and USB2.0.
5	HDMI™ Port	The dual HDMI™ ports can support up to 3840 x 2160 @ 60Hz resolution each.
6	2.5G PoE+ (POC-600) port/ 2.5G Ethernet (POC-610)	POC-600: 2.5Gb/s Power over Ethernet (PoE) port can provide both data and electric power to devices. POC-610: The Ethernet ports offer up to 2.5Gb/s transfer bandwidth per port.
7	3-pin terminal block (DC/ ignition input)	Compatible with DC power input from 8 to 35V, the terminal block can also be used for ignition signal input (with MezIO-V21 installed).

2.2.2 2.5G Ethernet Port

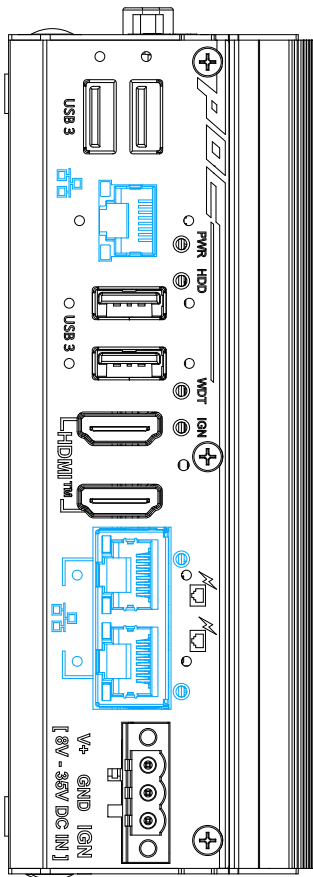

The system offers three 2.5Gb Ethernet ports using Intel® I225 GbE controller. From top to bottom, they are port #1, #2 and #3. When plugged in and connected via the Ethernet cable, the LEDs on the RJ45 connector indicate connection status and speed.

Active/Link LED (Right)

LED Color	Status	Description
Yellow	Off	Ethernet port is disconnected
	On	Ethernet port is connected and no data transmission
	Flashing	Ethernet port is connected and data is transmitting/receiving

Speed LED (Left)

LED Color	Status	Description
Off, Green or Orange	Off	10 Mbps
	Green	100 Mbps
	Orange	1000 Mbps
	Orange	2500 Mbps

2.2.3 IEEE 802.3at Power over Ethernet Port (POC-600 only)

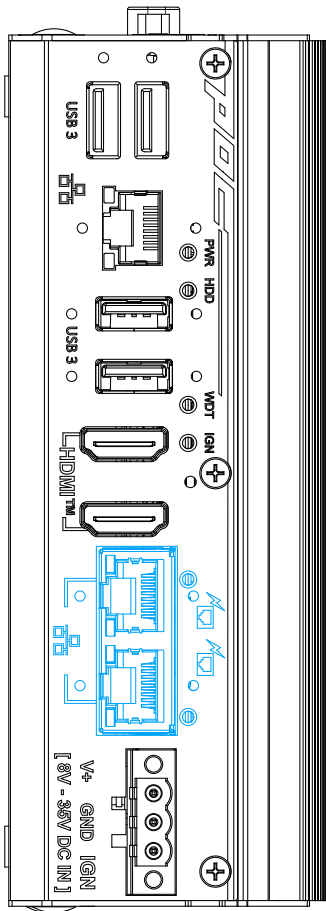

The Gigabit Power over Ethernet (PoE) port supply both power and data on a standard CAT-5/ CAT-6 Ethernet cable. Acting as a PSE (Power Sourcing Equipment), compliant with IEEE 802.3at, each port delivers up to 25W to a Powered Device (PD). PoE automatically detects and determine if the connected device is PoE PD or not before supplying power, making it compatible with standard Ethernet devices as well.

Active/Link LED (Right)

LED Color	Status	Description
Yellow	Off	Ethernet port is disconnected
	On	Ethernet port is connected and no data transmission
	Flashing	Ethernet port is connected and data is transmitting/receiving

Speed LED (Left)

LED Color	Status	Description
Off, Green or Orange	Off	10 Mbps
	Green	100 Mbps
	Orange	1000 Mbps
	Orange	2500 Mbps

2.2.4 System Status LED

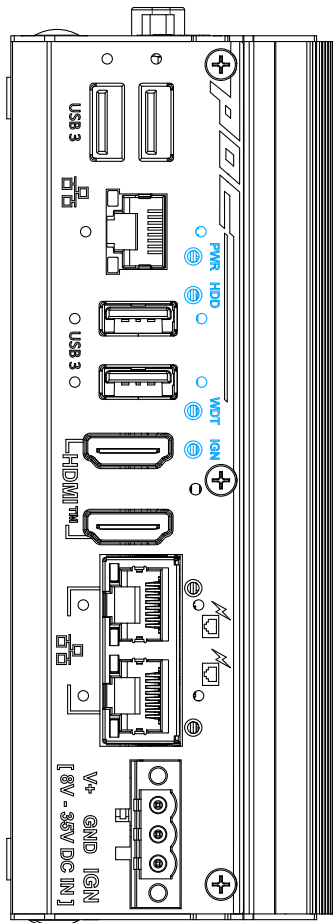

There are four LED indicators on the front panel: PWR, HDD, WDT and IGN. The descriptions of these four LEDs are listed in the following table.

Indicator	Color	Description
PWR	Green	Power indicator, lid when system is on
HDD	Red	Hard drive indicator, flashing when SATA HDD is active
WDT	Yellow	Watchdog timer indicator, flashing when watchdog timer has started
IGN	Yellow	If ignition option (MezIO-V20) is applied, this LED is used to indicate ignition signal status (lid when IGN signal is applied).

2.2.6 HDMI™ Port

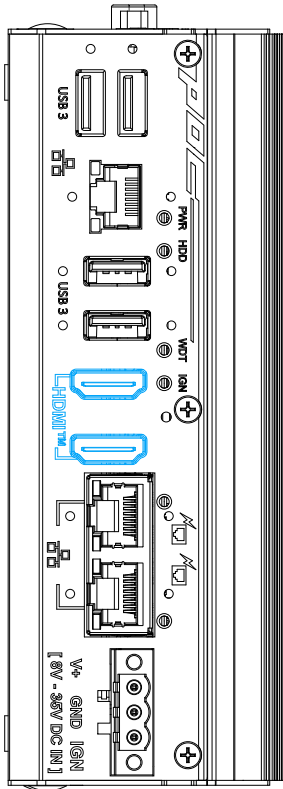

The High-Definition Multimedia Interface (HDMI) port provides uncompressed high-quality digital video and audio transmission between the system and a multimedia display device on a single cable. You can connect to other digital inputs by using a HDMI-to-DVI or HDMI-to-DP cable.



HDMI-to-DP

The system supports dual independent display outputs by connecting display devices DisplayPort connections. To support dual display outputs and achieve best DisplayPort output resolution in Windows, you need to install corresponding graphics drivers. Please refer to section [OS Support and Driver Installation](#) for details.

2.2.7 3-Pin Terminal Block

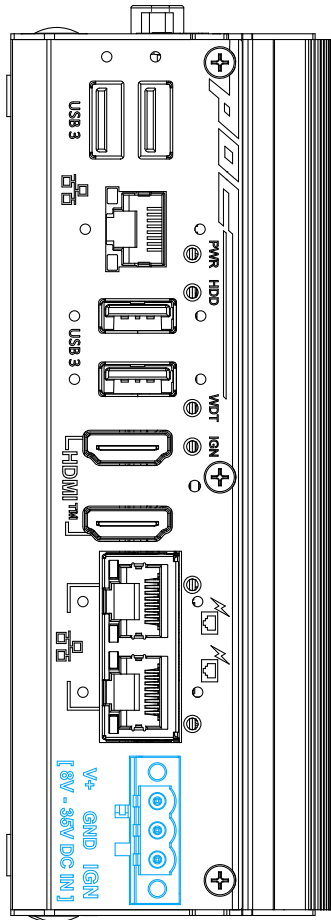

The system accepts a wide range of DC power input from 8 to 35V via a 3-pin pluggable terminal block, which is fit for field usage where DC power is usually provided. The screw clamping mechanism on the terminal block offers connection reliability when wiring DC power.

 **WARNING**

Please make sure the voltage of DC power is correct before you connect it to the system. Supplying a voltage over 35V will damage the system.

2.3 POC-600 Series COM Port Panel

The COM port panel of POC-600 series features additional I/O functions, such as a 3.5mm speaker-out/ microphone-in jack, COM ports and antenna holes for antenna installation.

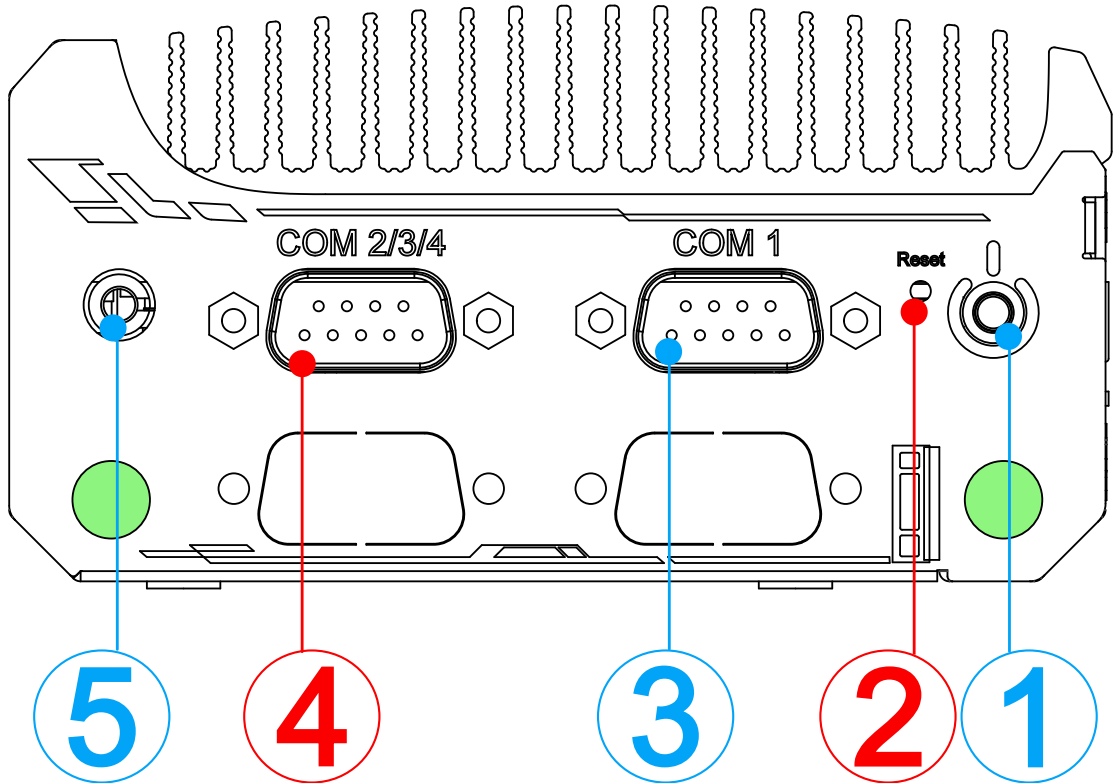

No.	Item	Description
1	Power button	Use this button to turn on or shutdown the system.
2	Reset button	Use this button to manually reset the system.
3	COM port 1	Software programmable RS-232/ 422/ 485 port
4	COM port 2/ 3/ 4	Can be configured as: COM2: single RS-422/ 485 port COM2/ COM3/ COM4: three 3-wire RS-232 ports
5	3.5mm microphone-in/ speaker-out jack	3.5mm jack for speaker-out or microphone-input.
		Opening reserved for SMA antenna installation

2.3.1 Power Button

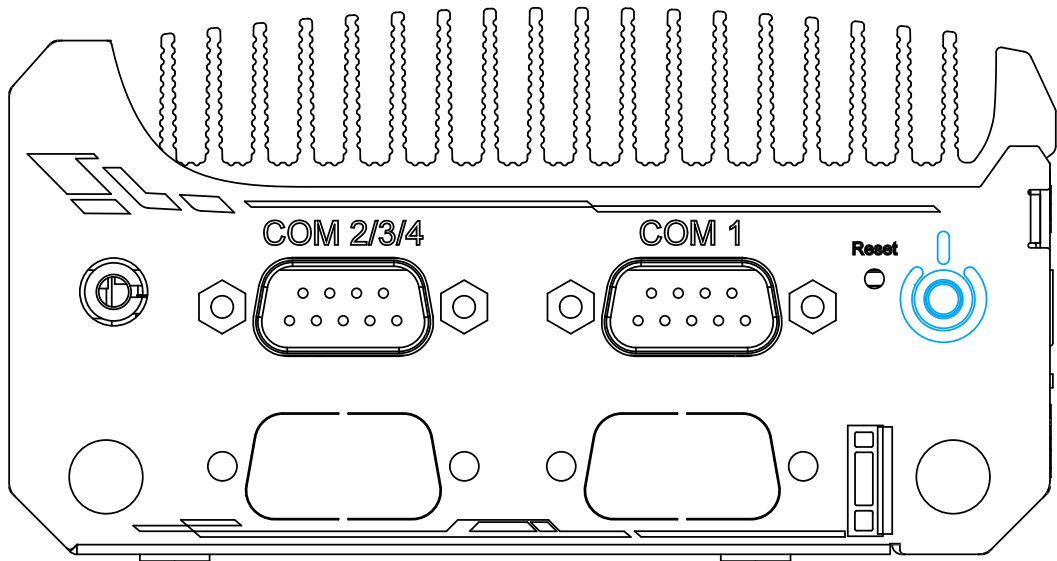

The power button is a non-latched switch for ATX mode on/off operation. Press to turn on the system, PWR LED should light up and to turn off, you can either issue a shutdown command in the OS, or just press the power button. In case of system halts, you can press and hold the power button for 5 seconds to force-shutdown the system. Please note that there is a 5 seconds interval between two on/off operations (i.e. once turning off the system, you will need to wait for 5 seconds to initiate another power-on operation).

2.3.2 Reset Button

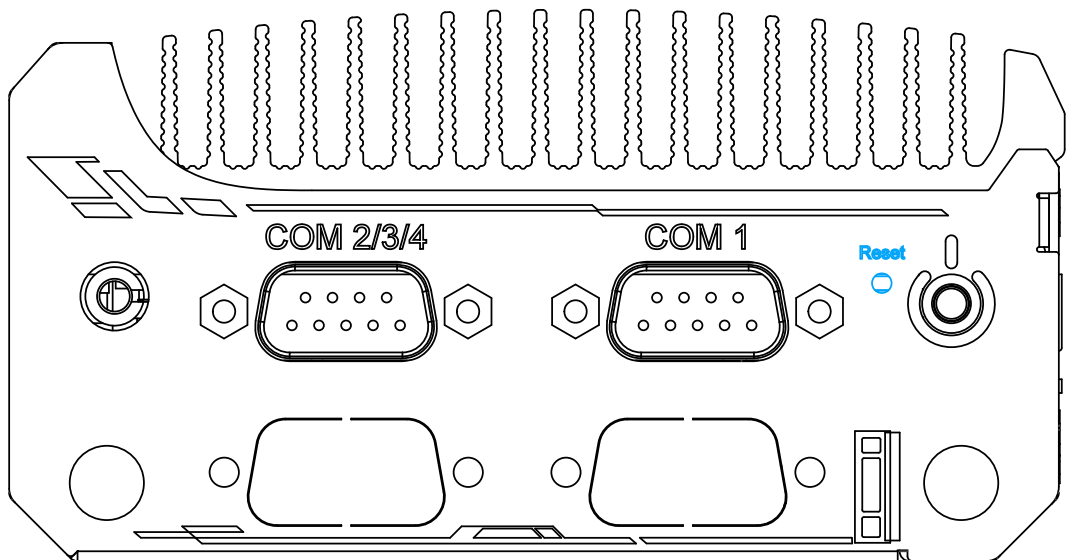

The reset button is used to manually reset the system in case of system halt or malfunction. To avoid unexpected reset, the button is purposely placed behind the panel. To reset, please use a pin-like object (eg. tip of a pen) to access the reset button.

2.3.3 COM Port (COM1)

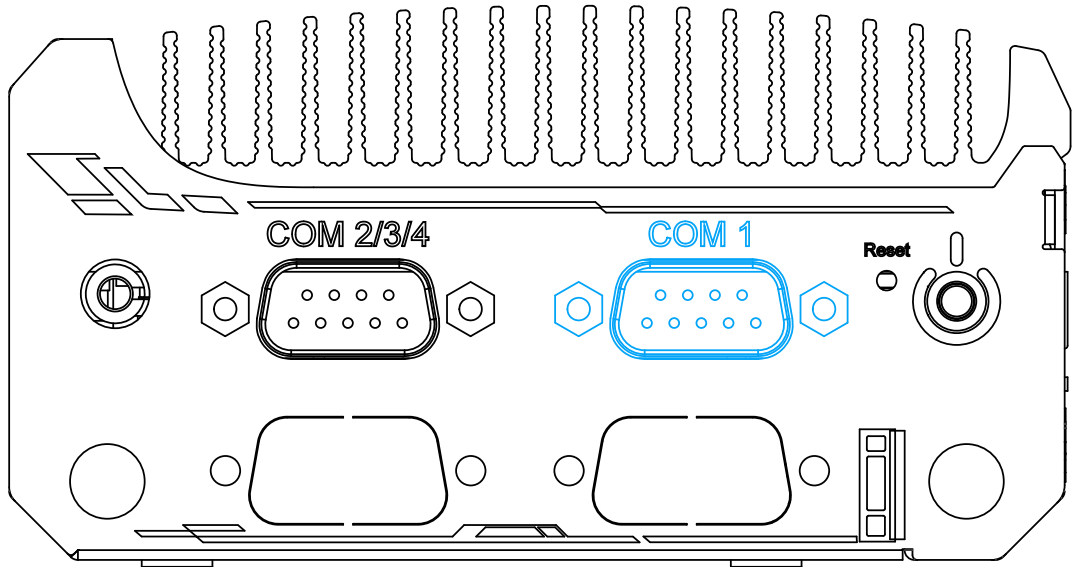

Implemented using industrial-grade ITE8786 Super IO chip (-40 to 85°C) and provide up to 921600 bps baud rate, COM1 is a software-configurable RS-232/422/485 port via 9-pin D-Sub male connector. The operation mode, slew rate and termination of COM1 can be set in BIOS setup utility. The following table describes the pin definition of COM ports.

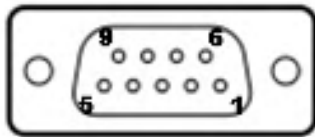

Pin#	COM1		
	RS-232 Mode	RS-422 Mode	RS-485 Mode (Two-wire 485)
1	DCD		
2	RX	422 TXD+	485 TXD+/RXD+
3	TX	422 RXD+	
4	DTR	422 RXD-	
5	GND	GND	GND
6	DSR		
7	RTS		
8	CTS	422 TXD-	485 TXD-/RXD-
9	RI		

2.3.4 COM Ports (COM2/ COM3/ COM4)

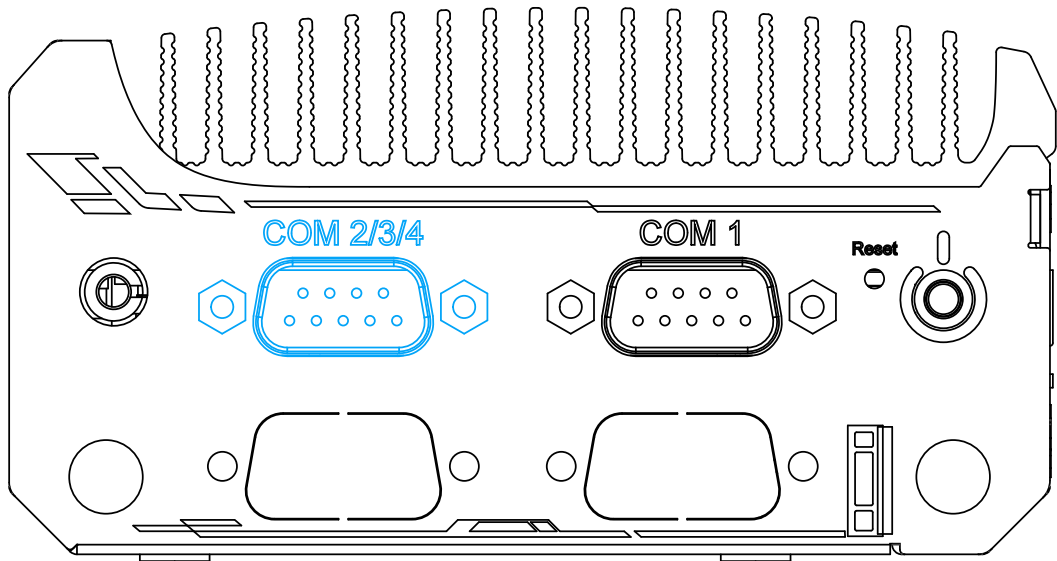

Implemented using industrial-grade ITE8786 Super IO chip (-40 to 85°C) and provide up to 921600 bps baud rate, the second D-Sub male connector (COM2/ 3/ 4) can be configured in BIOS as single RS-422/ 485 port (COM2) or three 3-wire RS-232 ports (COM2/COM3/COM4). Please refer to [COM2/ 3/ 4 Port Configuration](#) for configuring operation mode. An optional 1-to-3 Y-cable is available to connect three RS-232 devices.

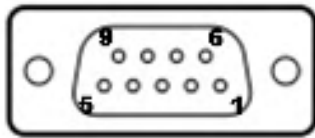

COM2/ 3/ 4 Pin



1-to-3 Y-cable

The following table describes the pin definition of the COM port

	3-port RS-232 COM2/ 3/ 4		
Pin#	COM2	COM3	COM4
1			
2	RX		
3	TX		
4		TX	
5	GND	GND	GND
6		RX	
7			TX
8			RX
9			

	Single port RS-422/ 485	
Pin#	RS-422	RS-485
1		
2	TxD+	TxD+/ RxD+
3	RxD+	
4	RxD-	
5	GND	GND
6		
7		
8	TxD-	TxD-/ RxD-
9		

2.3.5 3.5mm Microphone-in/ Speaker-out Jack

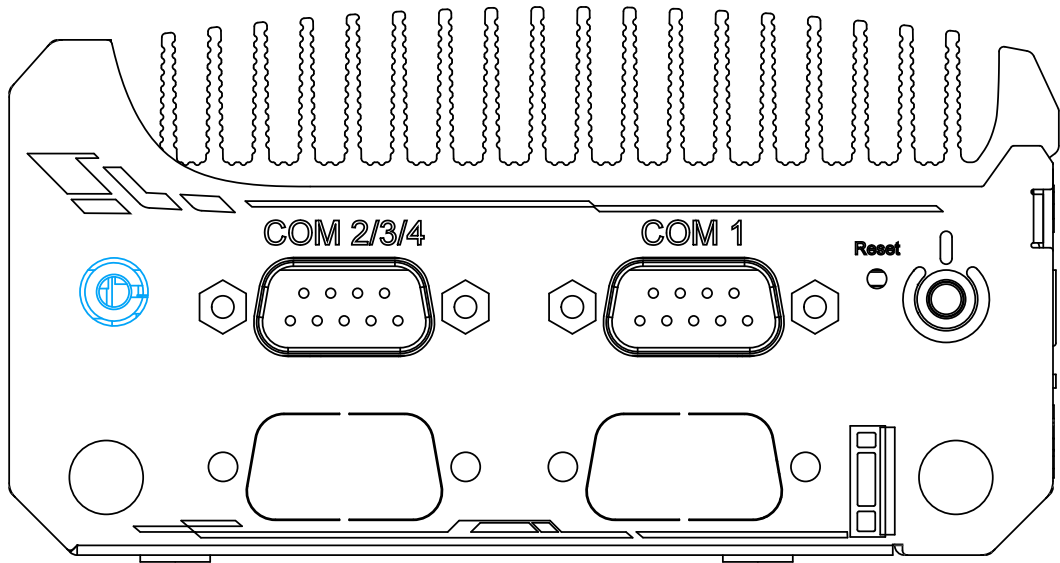

There is a single 3.5mm audio jack on the top panel. The port is used for microphone input as well as speaker output.

2.3.6 SMA Antennae Opening

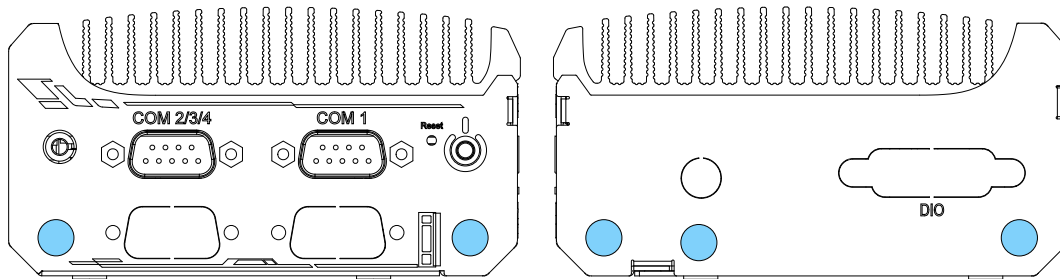

COM port side

DIO reserved port side

The system offers four SMA antenna openings reserved for SMA antenna installations. Users can take advantage of these four openings when installing M.2 E key module for wireless communication reception such as WiFi 5 or WiFi 6.

2.4 POC-600 Series Internal I/O

The system's internal I/O connectors consist of a SO-DIMM socket, M.2 2280 M key SATA interface port, M.2 E key port and a MezIO[®] port for application-oriented expansion purposes.

2.4.1 SO-DIMM Memory Socket

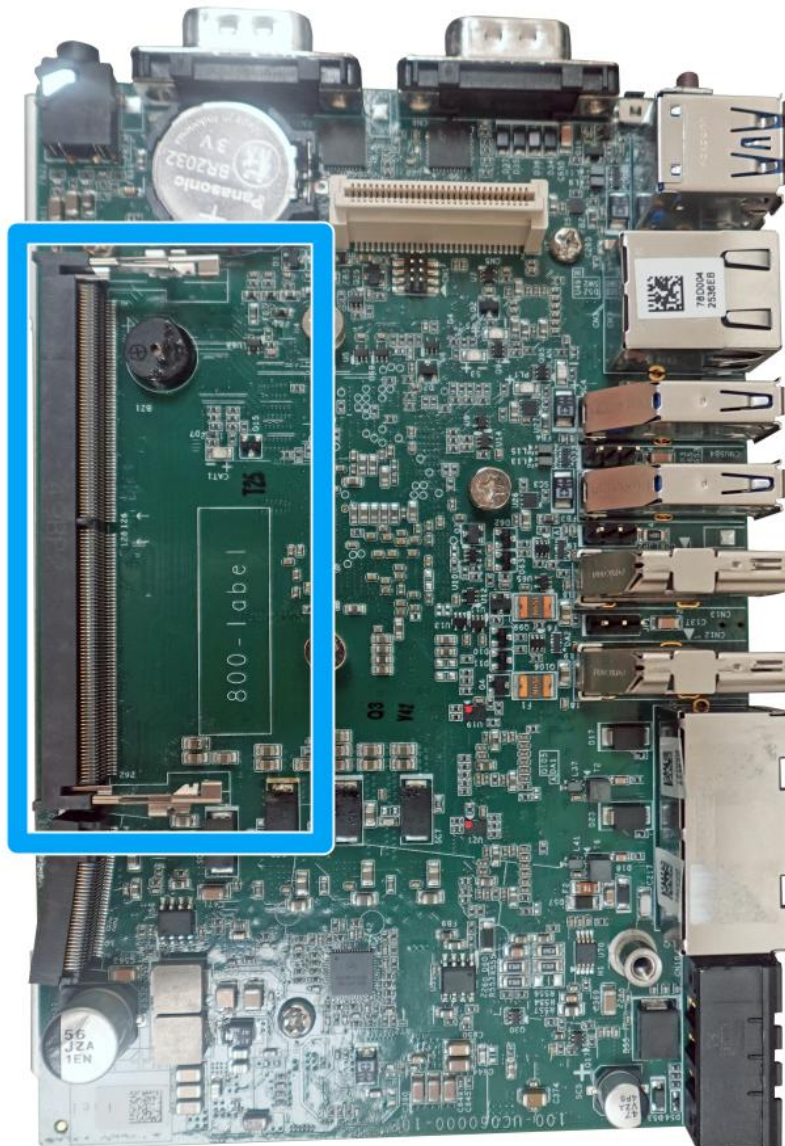

The system has an internal SO-DIMM slot supporting a single DDR5-4800 memory module up to 16GB in capacity.

2.4.2 M.2 2280 M Key



The system has an M.2 2280 slot (SATA signal only) for you to install an M.2 SATA SSD for faster access over traditional hard disk drives.



NOTE

The M.2 slot is only compatible with SATA signal M.2 SSD only.

M.2 2280 M Key Pin Definition

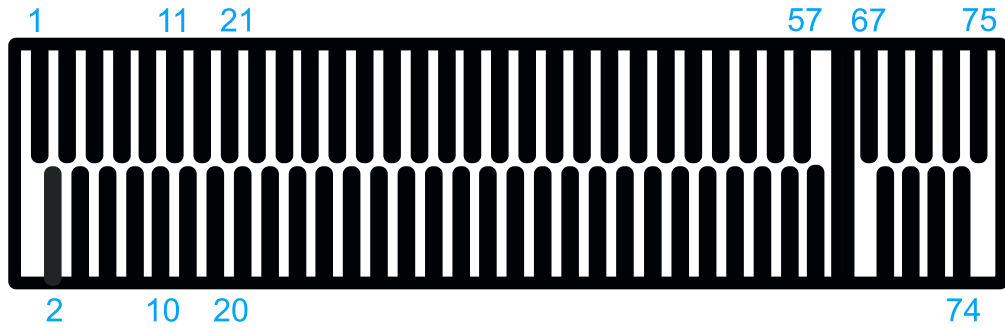

Pin #	Signal	Pin #	Signal
1	GND	2	+3V3
3	GND	4	+3V3
5		6	-
7		8	-
9	GND	10	DAS/DSS N
11		12	+3V3
13		14	+3V3
15	GND	16	+3V3
17		18	+3V3
19		20	-
21	GND	22	-
23		24	-
25		26	-
27	GND	28	-
29		30	-
31		32	-
33	GND	34	-
35		36	DEVSLP
37		38	-
39	GND	40	-
41	SATA-B+	42	-
43	SATA-B-	44	-
45	GND	46	-
47	SATA-A-	48	-
49	SATA-A+	50	PERST N
51	GND	52	-
53		54	-
55		56	-
57	GND	58	-
Mechanical Key			
67	-	68	SUSCLK
69	PEDET	70	+3V3
71	GND	72	+3V3
73	GND	74	+3V3
75	GND		

2.5 MezIO[®] Interface

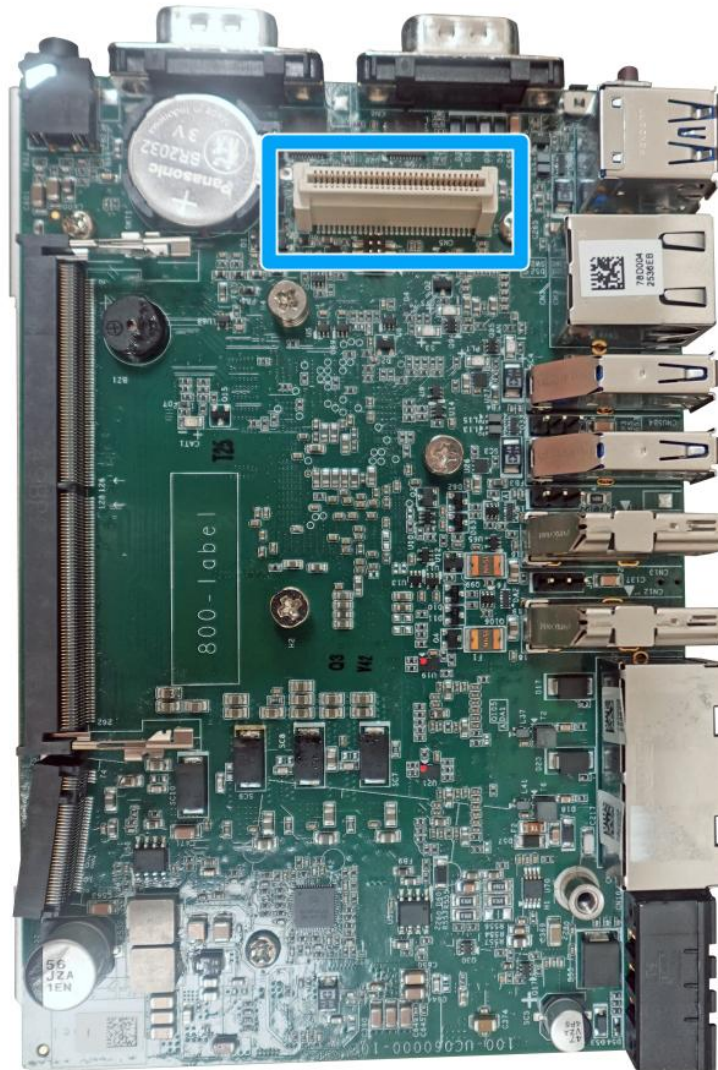

MezIO[®] is an innovative interface designed for integrating application-oriented I/O functions into an embedded system. It offers computer signals, power rails and control signals via a high-speed connector. MezIO[®] is also mechanically reliable benefited from its 3-point mounted mezzanine structure. A MezIO[®] module can leverage these signals to implement comprehensive I/O functions.

POC-600 series incorporates MezIO[®] interface and universal mechanical design to accommodate Neusys' standard MezIO[®] modules. For customers who want to develop their own MezIO[®] module, Neusys provides MezIO[®] design documents on a NDA basis. Please contact Neusys for further information.

2.5.1 MezIO[®] Interface Pin Definition



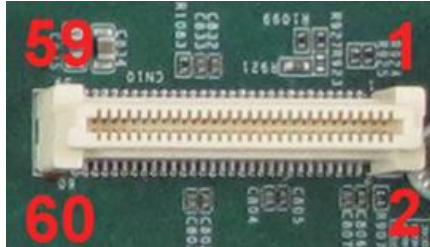





MezIO[®] interface leverages FCI BERGSTAK[®] board-to-board connector to provide interconnectivity of high-speed signals. The receptacle part on the PCBA is FCI 61082-063402LF while the plug part on the MezIO[®] module is FCI 61083-064402LF. Please refer to the following table for signal definition of its 60-pos connector.



Function Description	Signal	Pin#	Pin#	Signal	Function Description
Reserved	Reserved	1	2	PCIE_TXP_0	PCIe data pair
Reserved	Reserved	3	4	PCIE_TXN_0	PCIe data pair
Reserved	Reserved	5	6	GND	Ground
Reserved	Reserved	7	8	PCIE_RXP_0	PCIe data pair
System S4 signal	SLP_S4#	9	10	PCIE_RXN_0	PCIe data pair
Ground	GND	11	12	CLK100_P_0	PCIe clock pair
Reserved	Reserved	13	14	CLK100_N_0	PCIe clock pair
Ground	GND	15	16	GND	Ground
Reserved	UID_LED	17	18	PCIE_TXP_1	PCIe data pair
Platform reset	PLT_RST#	19	20	PCIE_TXN_1	PCIe data pair
USB data pair	USBP5_N	21	22	PCIE_RXP_1	PCIe data pair
USB data pair	USBP5_P	23	24	PCIE_RXN_1	PCIe data pair
Ground	GND	25	26	GND	Ground
SMB bus	SMB_DATA	27	28	CLK100_P_1	PCIe clock pair
SMB bus	SMB_CLK	29	30	CLK100_N_1	PCIe clock pair
N/C	N/C	31	32	GND	Ground
N/C	N/C	33	34	N/C	N/C
Ground	GND	35	36	N/C	N/C
N/C	N/C	37	38	GND	Ground
N/C	N/C	39	40	N/C	N/C
Power button	PWRBTN#	41	42	N/C	N/C
Reserved	Reserved	43	44	RXD4	SIO COM4
PCH GPIO	GPIO_RISE	45	46	TXD4	SIO COM4
PCH GPIO	GPIO_RISE	47	48	RXD5	SIO COM5
PCH GPIO	GPIO_RISE	49	50	TXD5	SIO COM5
Ground	GND	51	52	GND	Ground
3.3V power	P3V3	53	54	P1V8	1.8V power
3.3V power	P3V3	55	56	GND	Ground
5V power	P5V	57	58	P12V	12V power
5V power	P5V	59	60	P12V	12V power

2.5.2 MezIO® Modules for POC-600 Series

Neousys offers MezIO® modules to expand I/O functions for Neousys systems. With the addition of a MezIO® module into your system, it offers extra RS-232/ 422/ 485 ports, isolated digital I/ O, 2.5" HDD/ SSD accommodation, USB or ignition power control.

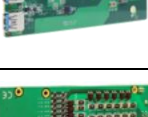
Model	Description	Product Photo
MezIO-R11	SATA port	
MezIO-R12	SATA port + 4x isolated DI/ 4x isolated DO	
MezIO-C180-50	4-port RS-232/422/485 + 4-port RS-232	
MezIO-C181-50	4-port RS-232/422/485 + 4-port RS-422/485	
MezIO-D220-50*	8-CH isolated DI + 8-CH isolated DO	
MezIO-D230-50*	16-CH isolated DI + 16-CH isolated DO	
MezIO-V21	16-mode ignition power control and 1x mini-PCIe socket (USB2.0 + PCIe signal) for in-vehicle usage	
MezIO-U4-30	4x USB3.1 Gen1 ports	
MezIO-D330	16-CH isolated DI 16-CH isolated DO	

3 System Installation

Before disassembling the system enclosure and installing components and modules, please make sure you have done the following:

- It is recommended that only qualified service personnel should install and service this product to avoid injury or damage to the system.
- Please observe all ESD procedures at all times to avoid damaging the equipment.
- Before disassembling your system, please make sure the system has powered off, all cables and antennae (power, video, data, etc.) are disconnected.
- Place the system on a flat and sturdy surface (remove from mounts or out of server cabinets) before proceeding with the installation/ replacement procedure.

3.1 Disassembling the System Enclosure

To install necessary components such as memory module, M.2 modules or MezIO™ module, you need to disassemble the POC-600 system enclosure:

1. To disassemble POC-600, remove the screws on the rear panel.



2. Remove the hex-bolt on COM ports.



3. Unfasten the screws at the bottom of the enclosure.



4. Gently slide the enclosure open.



5. Remove the screws indicated on the I/O panel, and remove the panel.



6. Remove the screw holding the DIO panel, and separate the DIO panel.

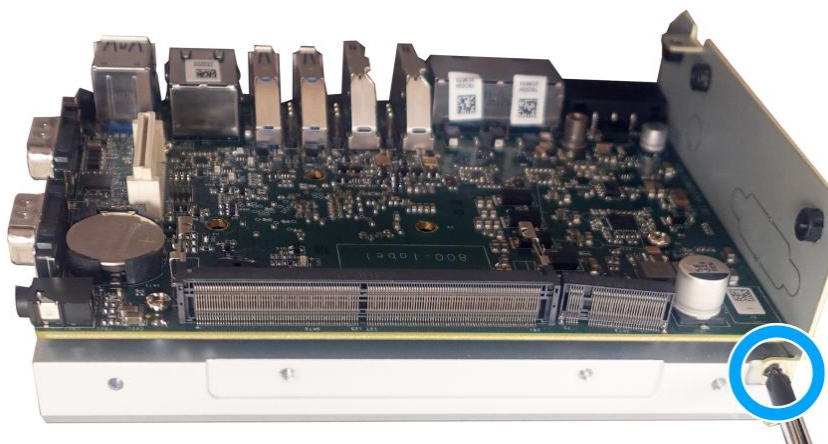

7. Remove the DRAM/ M.2 heatsink by unscrewing the screws indicated to gain access to internal expansion slots.



3.2 Installing Internal Components

3.2.1 SO-DIMM Installation

There is one SO-DIMM memory slot on POC-600 series motherboard. Please follow the procedures below to install the memory module.

1. [Disassemble the system enclosure](#)
2. The SO-DIMM slot can be located once the enclosure and heatsink have been removed.

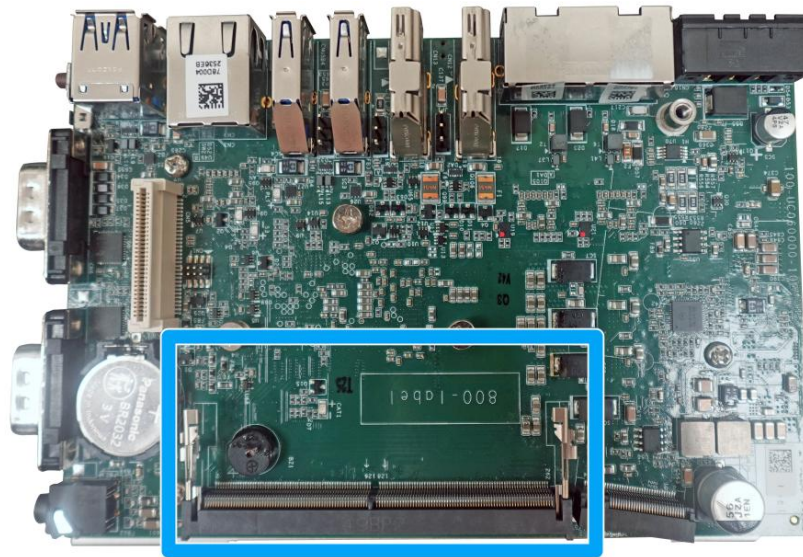

3. **To install**, insert the gold finger end of the SO-DIMM on a 45 degree angle.

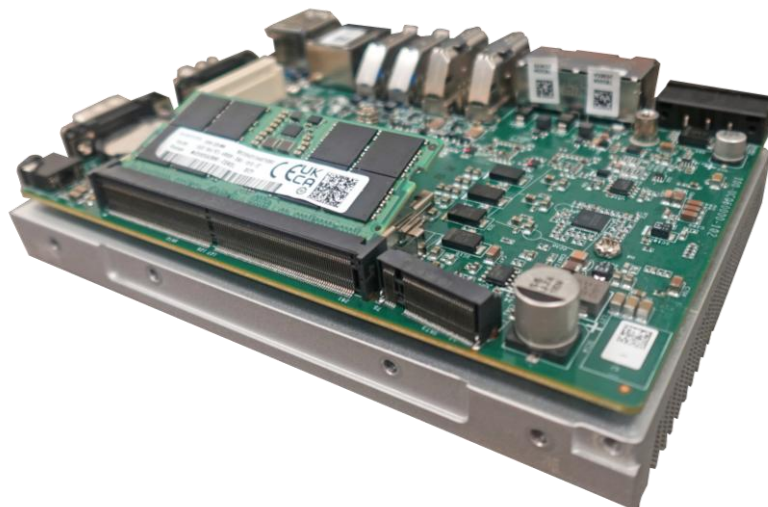

4. Gently push the SO-DIMM down until it clips-in.

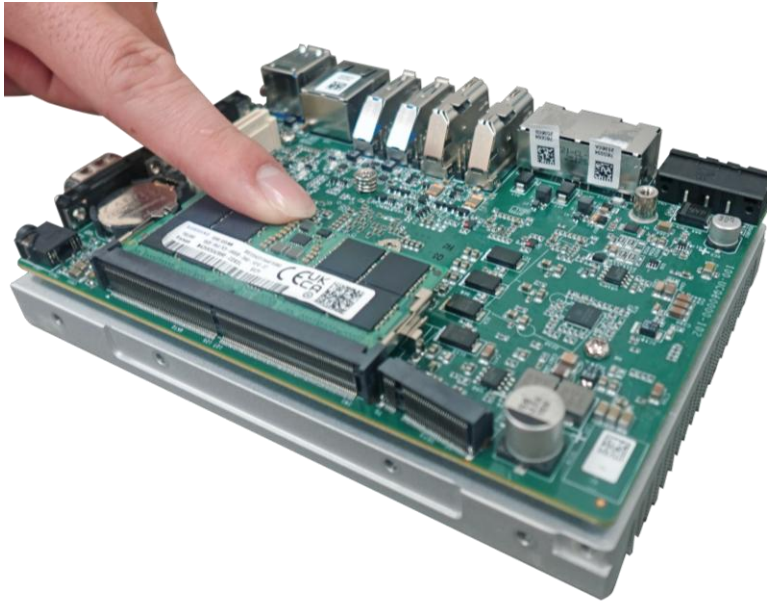

5. Remove the memory thermal pad protection film.



6. Reinstall the DRAM/ M.2 heatsink, and secure the heatsink with the screws indicated.



7. [Reinstall the system enclosure.](#)

3.2.2 M.2 2280 M Key Module Installation

There is an M.2 2280 M key module expansion slot on POC-600 series motherboard. Please follow the procedures below for installation.

1. [Disassemble the system enclosure.](#)
2. The M.2 2280 M key expansion can be located once the enclosure has been removed.

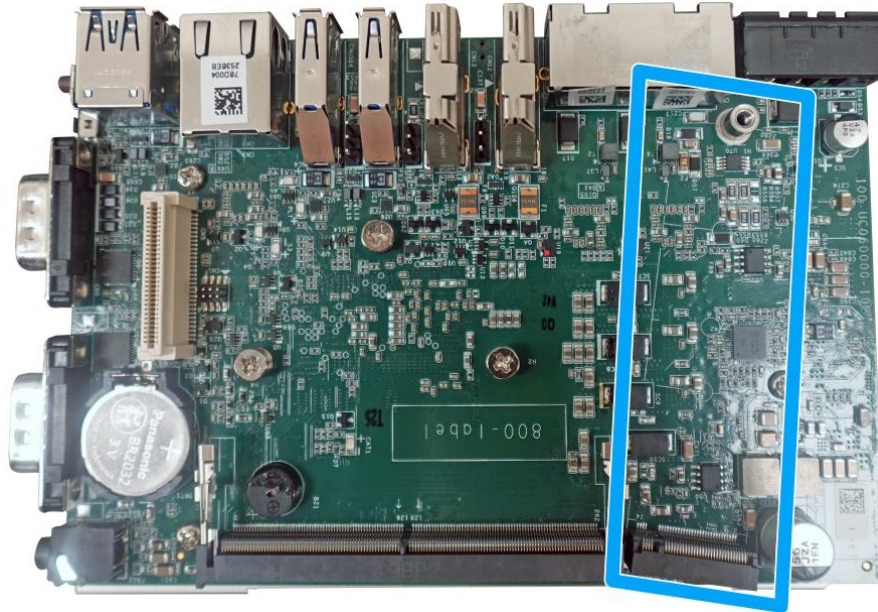

3. Insert the M.2 2280 module on a 45 degree angle.

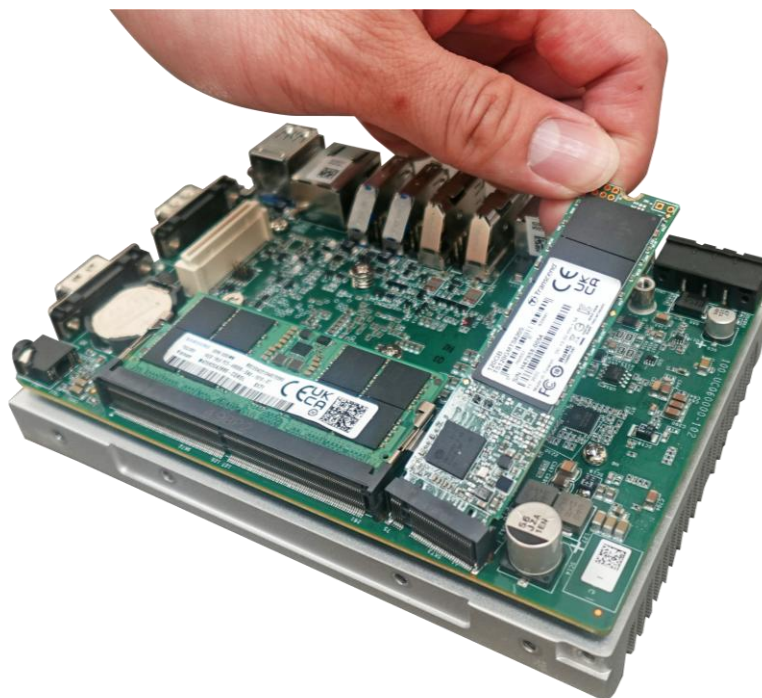

4. Gently press the card down and secure with a screw.



5. Remove the thermal pad protection film for M.2 module.



8. Reinstall the DRAM/ M.2 heatsink, and secure the heatsink with the screws indicated.



6. [Reinstall the system enclosure.](#)

3.2.3 MezIO[®] Module Installation

The system comes with a MezIO[®] module expansion slot. For specific MezIO[®] module I/O functionalities, please refer to the [MezIO[®] Module](#) section. For installation, please refer to the following procedure.

1. [Disassemble the system enclosure](#), but do not remove the DRAM heatsink.
2. The MezIO[®] module expansion slot can be located once the enclosure has been removed.

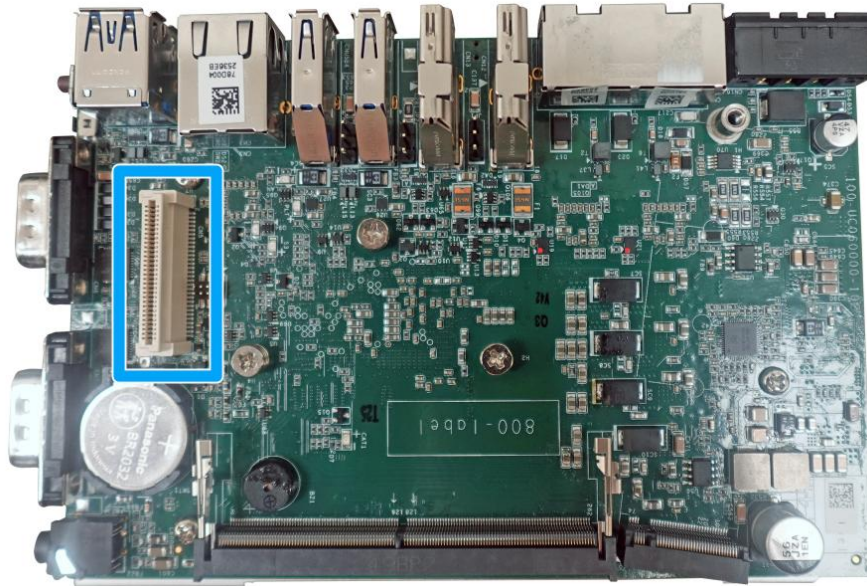

3. The stand-off hex bolts are shipped with MezIO[®] module. POC-600 comes with M3, P-head screws, we need to remove P-head screws and replace them with stand-off bolts

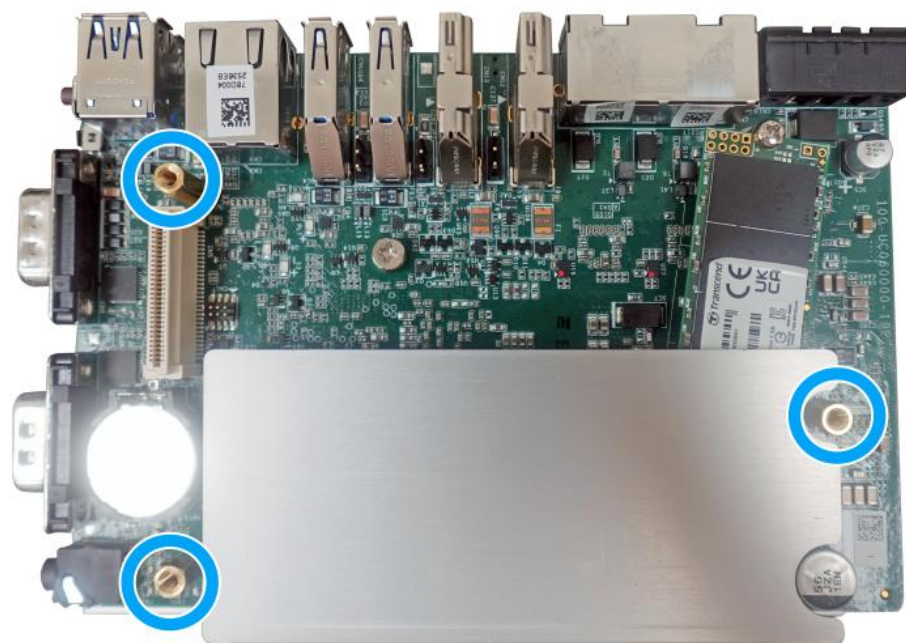

4. To install, match the three (3) screw holes to the standoffs and the MezIO[®] port, gently lower the module onto the PCBA. The MezIO[®] port should engage if the three (3) standoffs and screw holes meet.



5. Then using the three (3) screws supplied, secure the module by fastening a screw on each standoff.

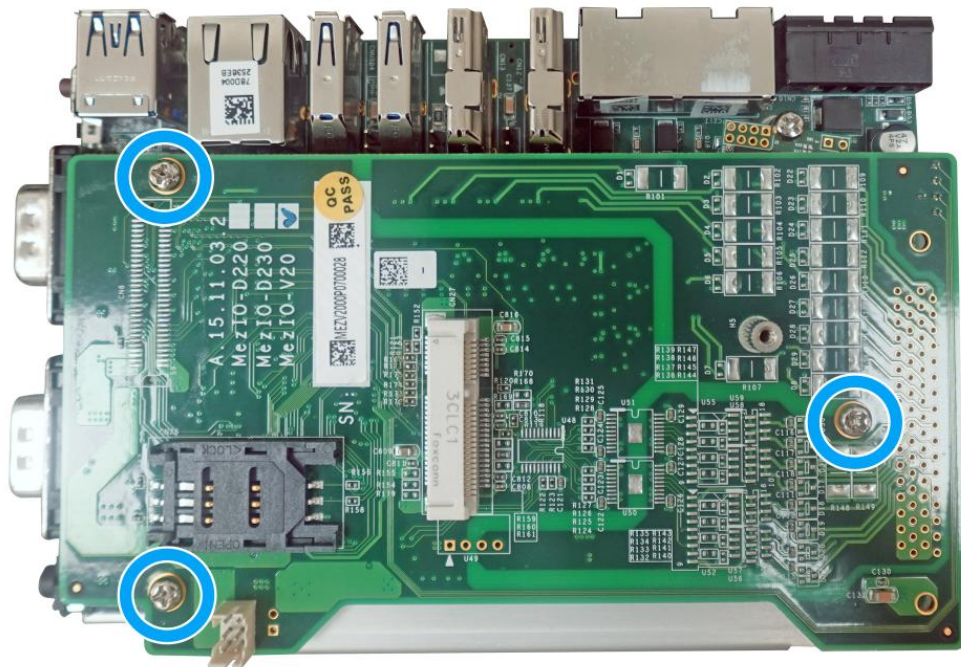

6. If you are installing a new MezIO[®] module into your system, you may need to remove the punch-out plate depending on your MezIO[®] expansion needs.

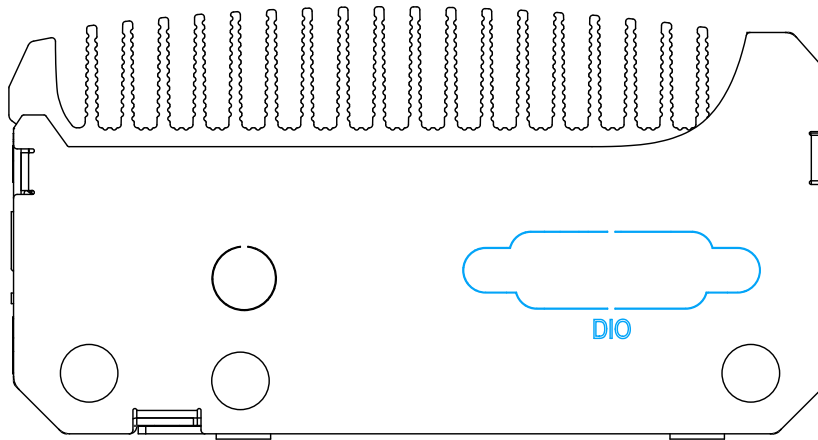

7. [Reinstall the system enclosure.](#)

3.3 Installing the System Enclosure

1. To reinstall the system enclosure, please make sure the DRAM/ M.2 heatsink has been installed.



2. Install the DIO panel and secure the panel screw indicated.

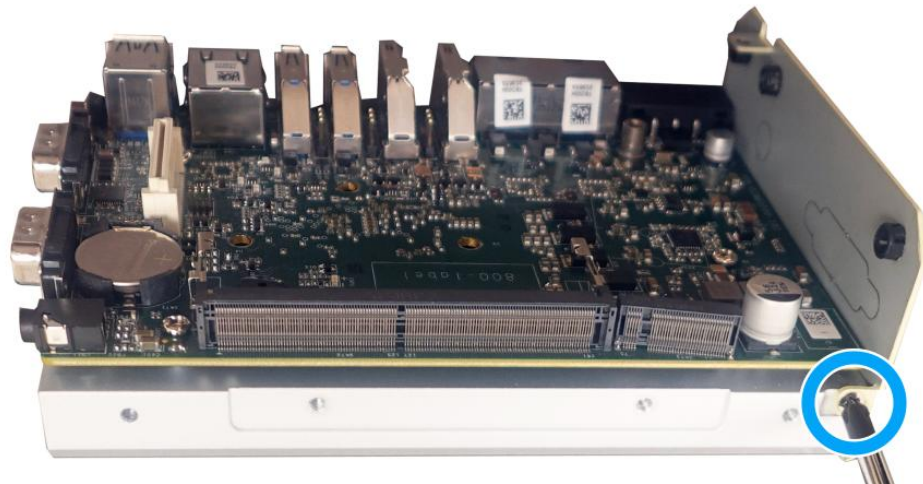

3. Install the I/O panel and secure the screws indicated.



- Gently slide the L-shaped enclosure back in place making sure the screw hole on the hinge sits on the inside.

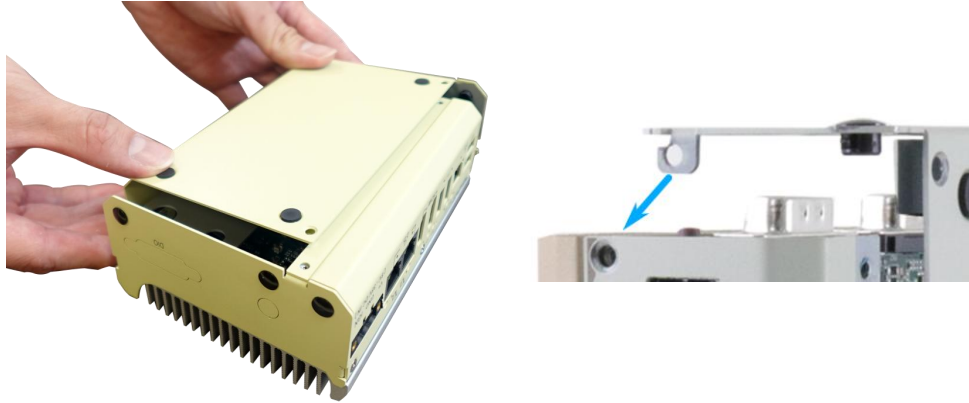

Place enclosure back in-place

Make sure hinge sits on the inside

- Complete installing the system enclosure by fastening the screws indicated below.



COM port hex-bolt

Rear panel



Bottom of the enclosure

3.4 DIN Rail Installation

The DIN rail is easy to install and it is a convenient way to position the system. The DIN rail has been proven to be most beneficial in the industrial environment where space is limited. The mount plate comes with two M4 screws. Please refer to the illustrations below to install the DIN clip/ rail.

1. To install, secure the DIN rail clip onto the rear of the system enclosure using the M4 screws provided.



2. To install the mount plate onto the DIN rail, you must come over the top of the DIN rail, tilting downwards, overlap the top clip edge of the mount plate onto the DIN rail first, then firmly press the bottom-front of the enclosure to clip the bottom edge of the mount plate.

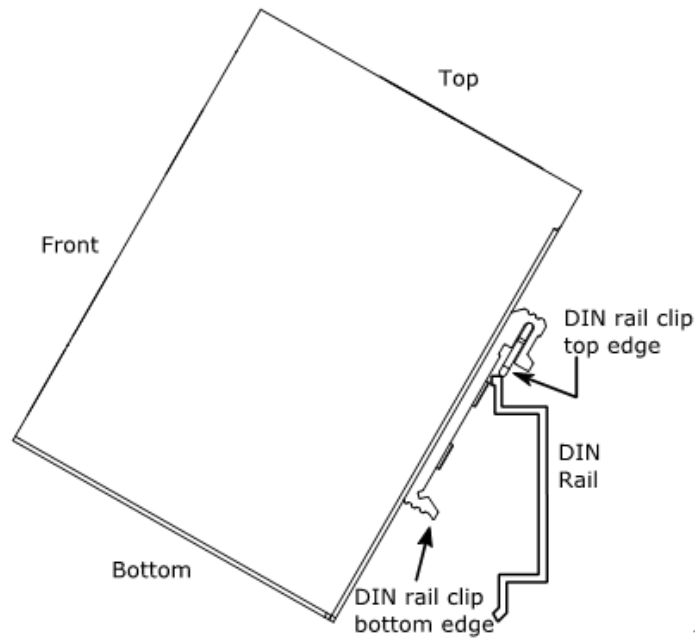

3. Confirm the mount plate has indeed clipped onto the DIN rail for proper fit to complete the installation.

3.5 Wall Mount Installation (Optional Accessory)

3.5.1 Standard Wall Mount (Optional Accessory)

The optional wall mount bracket allows the system to be mounted horizontally. Please refer to the following installation procedure to install the wall mount.

1. Remove the rubber pads indicated at the bottom of the system.

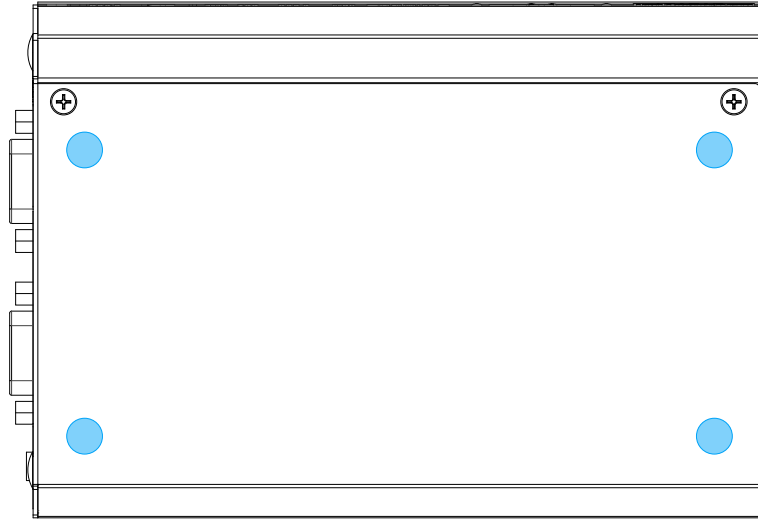

2. To install, secure the wall mount bracket to the bottom of the system enclosure using the M4 screws provided.

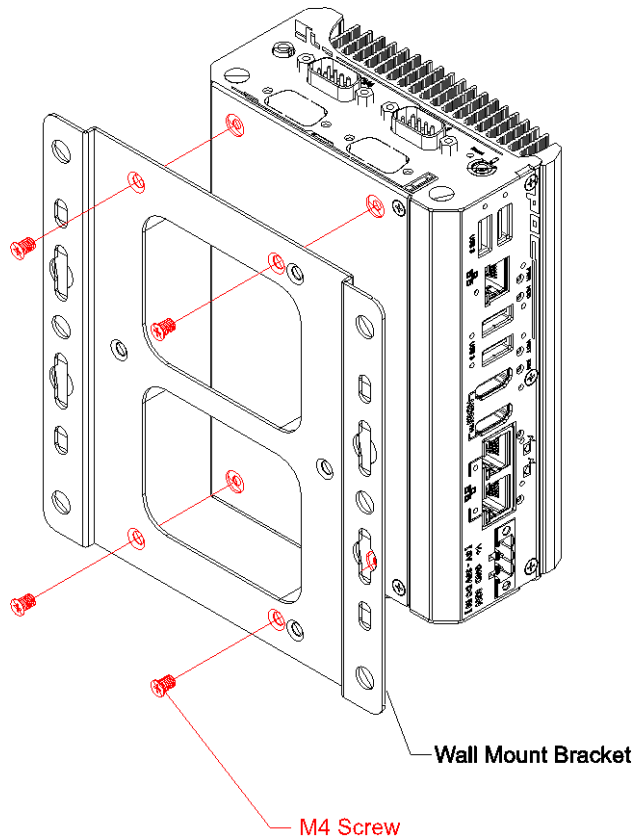

3. Dimension illustration of the installed wall mount bracket for your reference.

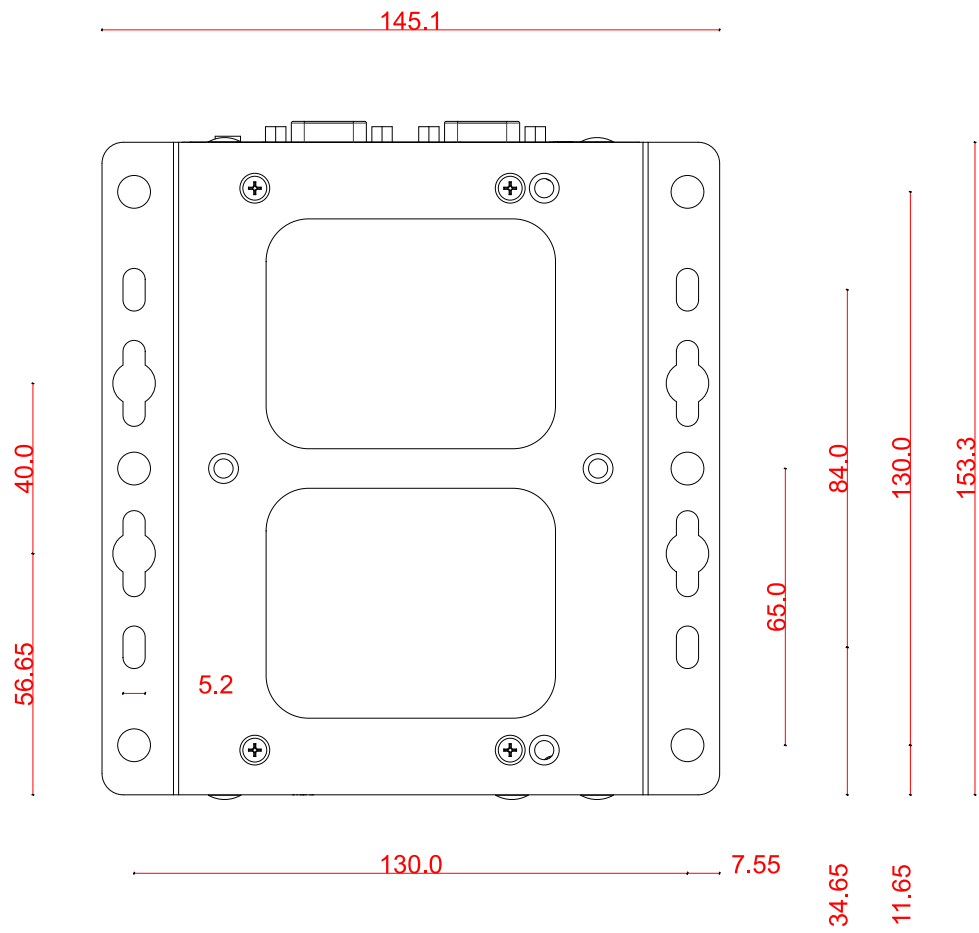

3.5.2 Vertical Wall Mount (Optional Accessory)

- To install, secure the wall mount bracket to the rear side panel of the system enclosure using the M4 screws provided.

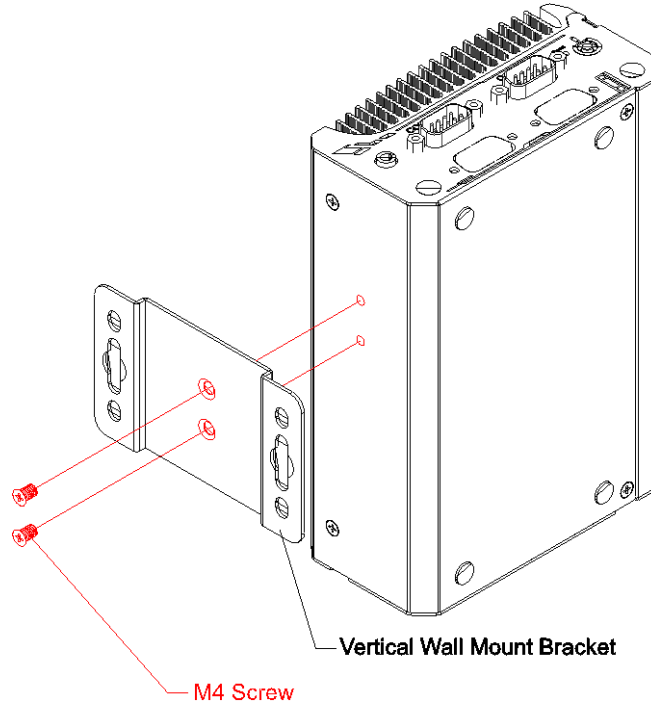

- Dimension illustration of the installed vertical wall mount bracket for your reference.

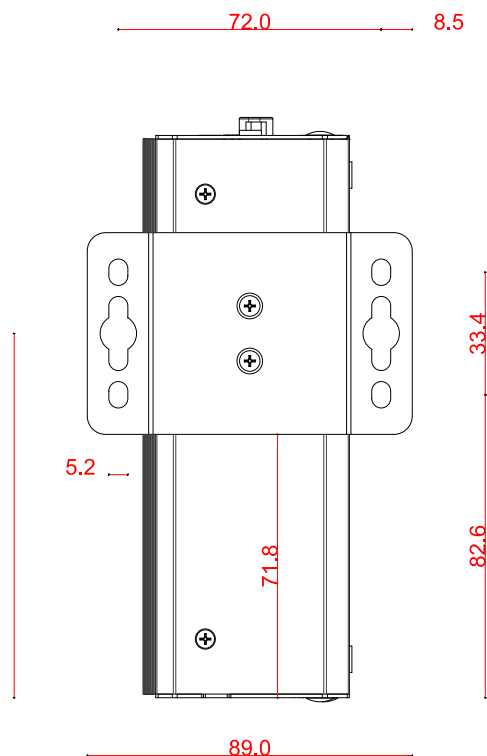

3.6 Powering On the System

There are five methods to power on the system

- Pressing the power button
- Via an external non-latched switch
- Sending a LAN packet via Ethernet (Wake-on-LAN)
- Using the ignition signal input (if MezIO-V21 is installed)

We will describe the processes and actions involved for the first four methods in this section and the ignition signal input method will be described in section 3.7.

3.6.1 Powering On Using the Power Button

This is the simplest way to turn on your system. The power button on the front panel is a non-latched switch and behaves as the ATX-mode on/off control. With DC power connected, pushing the power button will turn on the system and the PWR LED indicator will light up. Pushing the button when system is on will turn off the system. If your operating system supports ATX power mode (i.e. Microsoft Windows or Linux), pushing the power button while the system is in operation will result in a pre-defined system behavior, such as shutdown or hibernation.

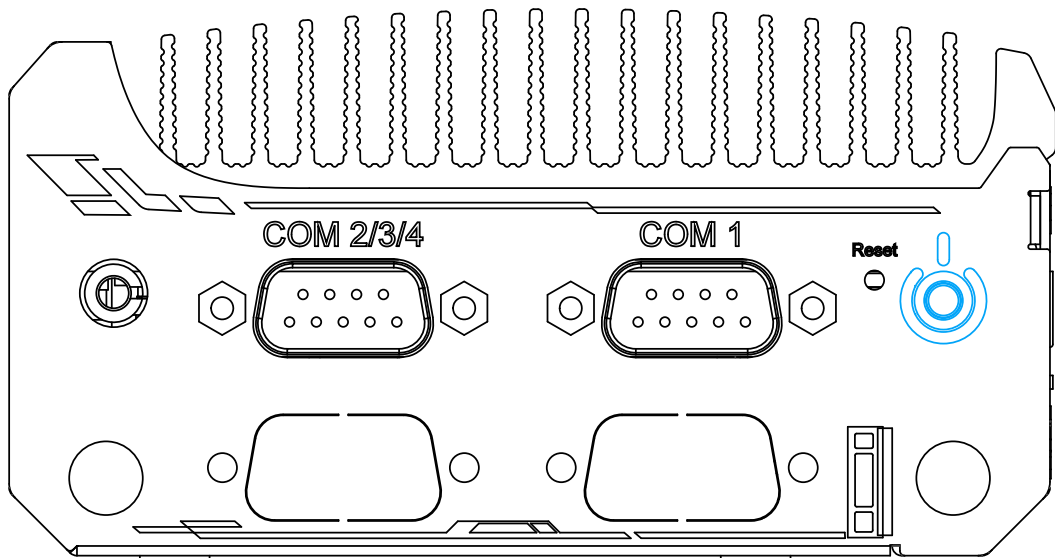

3.6.2 Powering On Using An External Non-Latched Switch

For an application which places the system inside a cabinet, it's useful to control powering on/off the system using an external switch. The system provides an on-board connector for connecting a latched/ non-latched switch and behaving either AT-mode or ATX-mode power on/off control.

When using the ATX-mode on/ off control, you need a non-latch switch. The external non-latched switch acts exactly the same as the power button on the front panel. Please follow the steps below to install an external non-latch switch.

1. Prepare a non-latched switch with a 2-pin, 2.0mm pitch connector

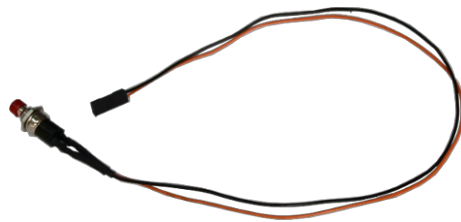

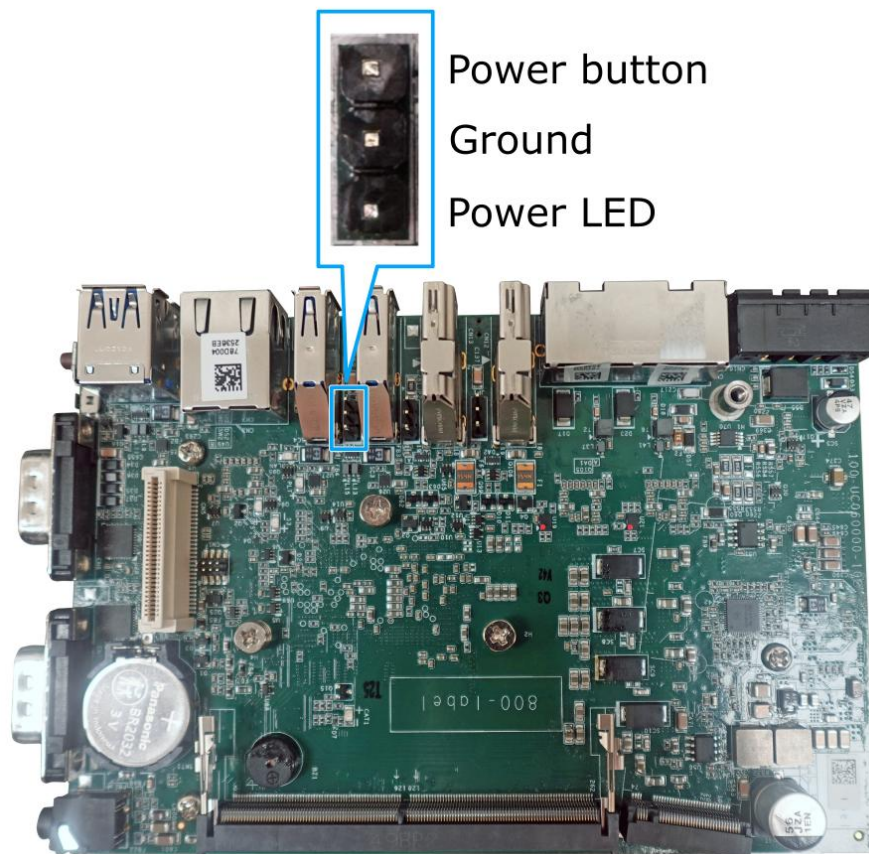

2. Connect the non-latched switch to the power button and ground pins, 2.0mm pitch pin header (polarity is negligible). Press the button on the switch to turn on the system.

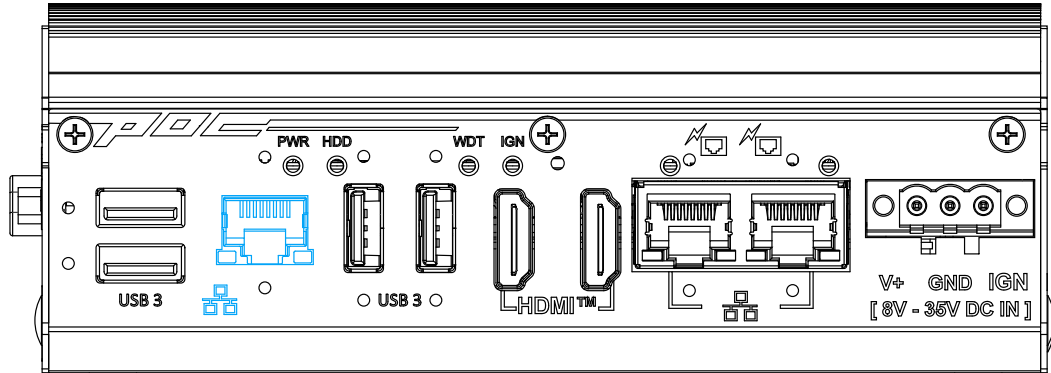

3.6.3 Powering On Using Wake-on-LAN

Wake-on-LAN (WOL) is a mechanism to wake up a computer system from a S5 (system off with standby power) state via issuing a magic packet. The system's Wake-on-LAN compatible GbE port is shown below.



 **NOTE**

Please make sure the Intel chipset and Ethernet driver has been properly installed prior to setting up WOL function.

To enable WOL function, please set up WOL settings in the BIOS and in the operating system by follow the steps described below.

1. When the system boots up, press F2 to enter BIOS setup utility.
2. Go to the **[Power]>[Wake On LAN]** and set it to **[Enabled]**.
3. Press F10 to **“Save changes and exit BIOS”** and allow the system boot into the operating system.
4. Once booted into the Windows system, press **“Windows key + E”**, right-click on **“Network>Properties>Change adapter**

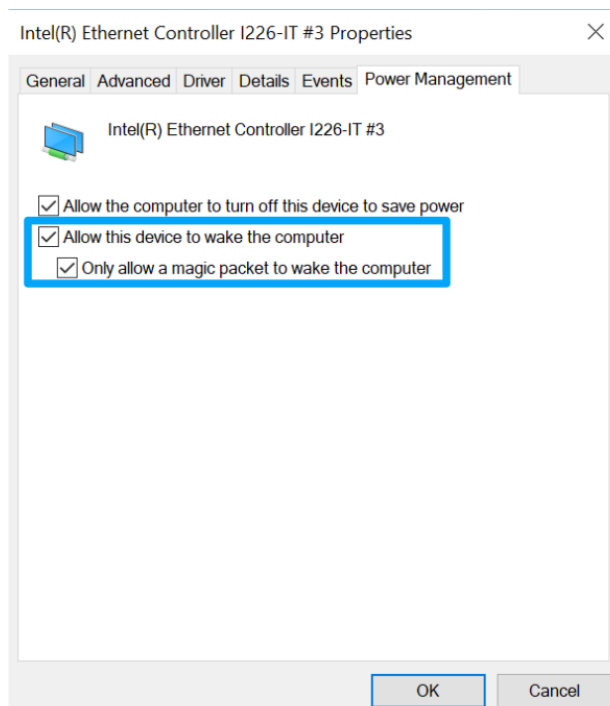

settings". Locate and double-click on the adapter Intel® I226 Gigabit Network Connection, click on **Configure**.

5. Click on the **Power Management** tab and check the following options. Click on OK when done.

Magic Packet

The magic packet is a broadcast frame containing anywhere within its payload 6 bytes of all 255 (FF FF FF FF FF FF in hexadecimal), followed by sixteen repetitions of the target computer's 48-bit MAC address.

For example, NIC's 48-bit MAC Address is 78h D0h 04h 0Ah 0Bh 0Ch

DESTINATION SOURCE MISC

FF FF FF FF FF FF

78 D0 04 0A 0B 0C 78 D0 04 0A 0B 0C

78 D0 04 0A 0B 0C 78 D0 04 0A 0B 0C

78 D0 04 0A 0B 0C 78 D0 04 0A 0B 0C

78 D0 04 0A 0B 0C 78 D0 04 0A 0B 0C

78 D0 04 0A 0B 0C 78 D0 04 0A 0B 0C

78 D0 04 0A 0B 0C 78 D0 04 0A 0B 0C

78 D0 04 0A 0B 0C 78 D0 04 0A 0B 0C

78 D0 04 0A 0B 0C 78 D0 04 0A 0B 0C

MISC CRC

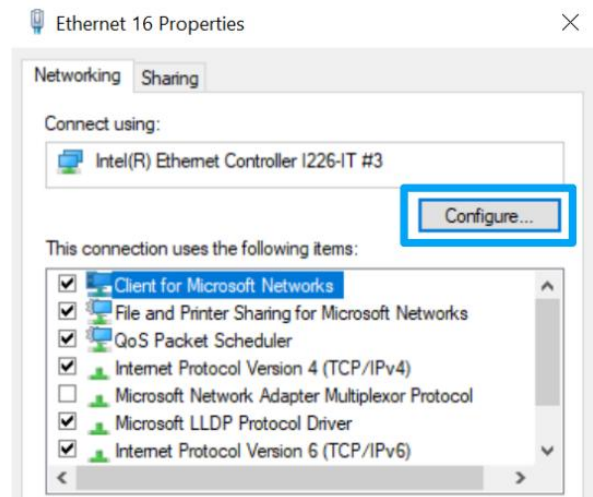

There are some free tools available on Internet that can be used to send a magic packet. Please refer to the following link to understand more about [Magic Packet](#).

4 BIOS Settings

The system is shipped with factory-default BIOS settings optimized for best performance and compatibility. In this section, we'll illustrate some BIOS settings you may need to set or change prior to operating system installation. Please always make sure you understand the effect of change before you proceed with any changes. If you are unsure of the function you are changing, it is recommended to change one setting at a time to see its effect(s).

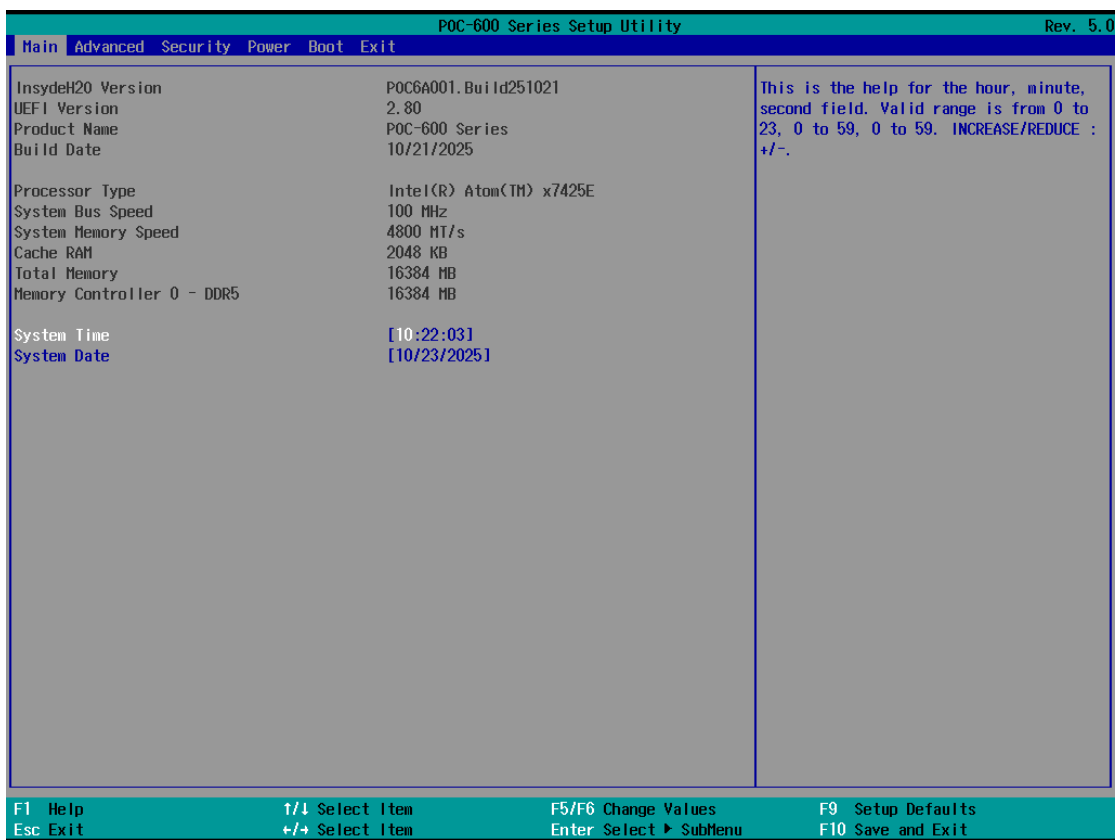

 **NOTE**

Not all BIOS settings will be discussed in this section. If there is a particular BIOS setting you are after but is not discussed in this section, please contact Neousys Technical Support staff.

4.1 COM1 Port Configuration

The system's [COM1 port](#) supports RS-232 (full-duplex), RS-422 (full-duplex) and RS-485 (half-duplex) mode. You can set the COM1 operating mode via BIOS settings. Another option in BIOS called “*Slew Rate*” defines how sharp the rising/falling edge is for the output signal of COM1. For long-distance RS-422/485 transmission, you may set the “*Slew Rate*” option as “High” to improve signal quality. For RS-422/485 communication, the “*RS-422/485 Termination*” option determines whether to enable/disable internal termination of RS-422/485 transceiver according to your wiring configuration (e.g. with or without external termination).

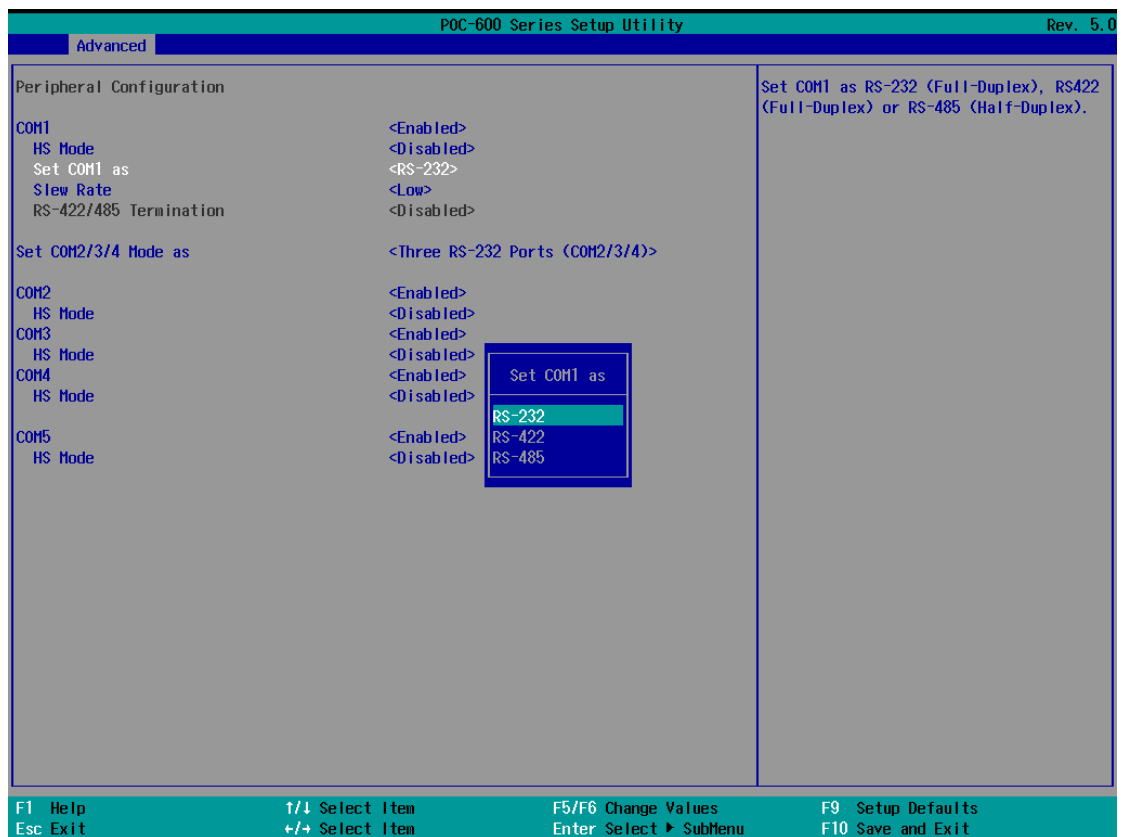

To set COM1 operating mode:

1. Press **F2** when the system boots up to enter the BIOS setup utility.
2. Go to **[Advanced]** → **[Peripheral Configuration]**.
3. Set the **[Set COM1 Mode as]** option to the desired mode.
4. Once set, press **F10** to save setting and exit.

4.1.1 COM Port High Speed Mode

The high speed mode of each COM port effectively allows for the port's baud rate generator to operate at 8x the speed with an effective baud rate of 921,600 bps (115,200 x 8). Please refer to the following instructions on how to enable the high speed mode for your COM port (COM1 used as an example).

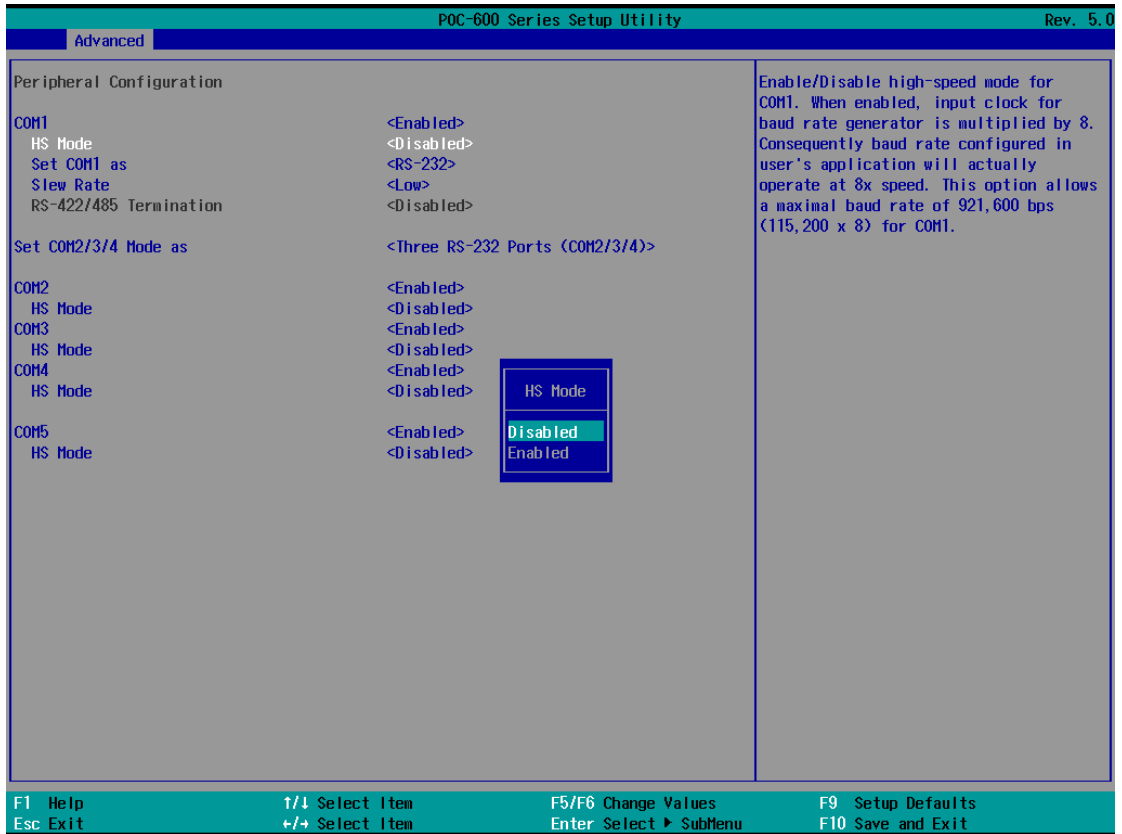

To set COM port high speed mode:

1. Press **F2** when the system boots up to enter the BIOS setup utility.
2. Go to **[Advanced] > [Peripheral Configuration]**.
3. Enable or set the **[Set COM1 Mode as]** option to the desired mode.
4. Highlight **[HS Mode]** and press ENTER to bring up options, highlight **[Enable]** and press ENTER.
5. Once set, press **F10** to save setting and exit.

4.1.2 COM Port Slew Rate

Another option in BIOS called “*Slew Rate*” defines how sharp the rising/falling edge is for the output signal of COM1. For long-distance RS-422/ 485 transmission, you may set the “*Slew Rate*” option as “High” to improve signal quality. For RS-422/485 communication, the “*RS-422/ 485 Termination*” option determines whether to enable/disable internal termination of RS-422/ 485 transceiver according to your wiring configuration (e.g. with or without external termination).

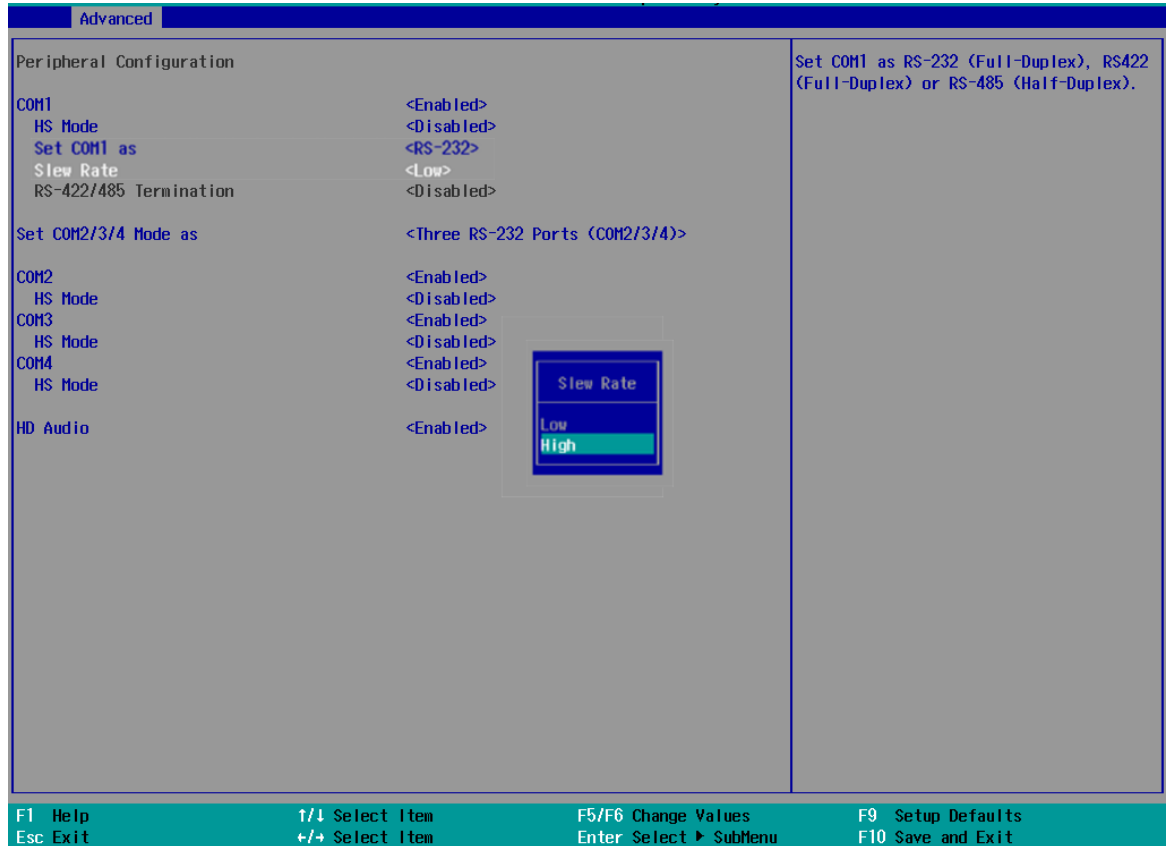

To set COM port Slew rate:

1. Press **F2** when the system boots up to enter the BIOS setup utility.
2. Go to **[Advanced]** → **[Peripheral Configuration]**.
3. Select and highlight the COM port > **[Slew Rate]**.
4. Set it to the desired mode **[Low]** or **[High]** and press Enter.
5. Once set, press **F10** to save setting and exit.

4.2 COM2/ 3/ 4 Port Configuration

The system's [COM2/ 3/ 4 ports](#) support RS-232 (full-duplex) while COM2 also supports RS-422 (full-duplex) and RS-485 (half-duplex) mode. The operating mode can be configured via the BIOS. Another option in BIOS called “Slew Rate” defines how sharp the rising/falling edge is for the output signal. For long-distance RS-422/485 transmission, you may set the “Slew Rate” option as “High” to improve signal quality. For RS-422/485 communication, the “RS-422/485 Termination” option determines whether to enable/disable internal termination of RS-422/485 transceiver according to your wiring configuration (e.g. with or without external termination).

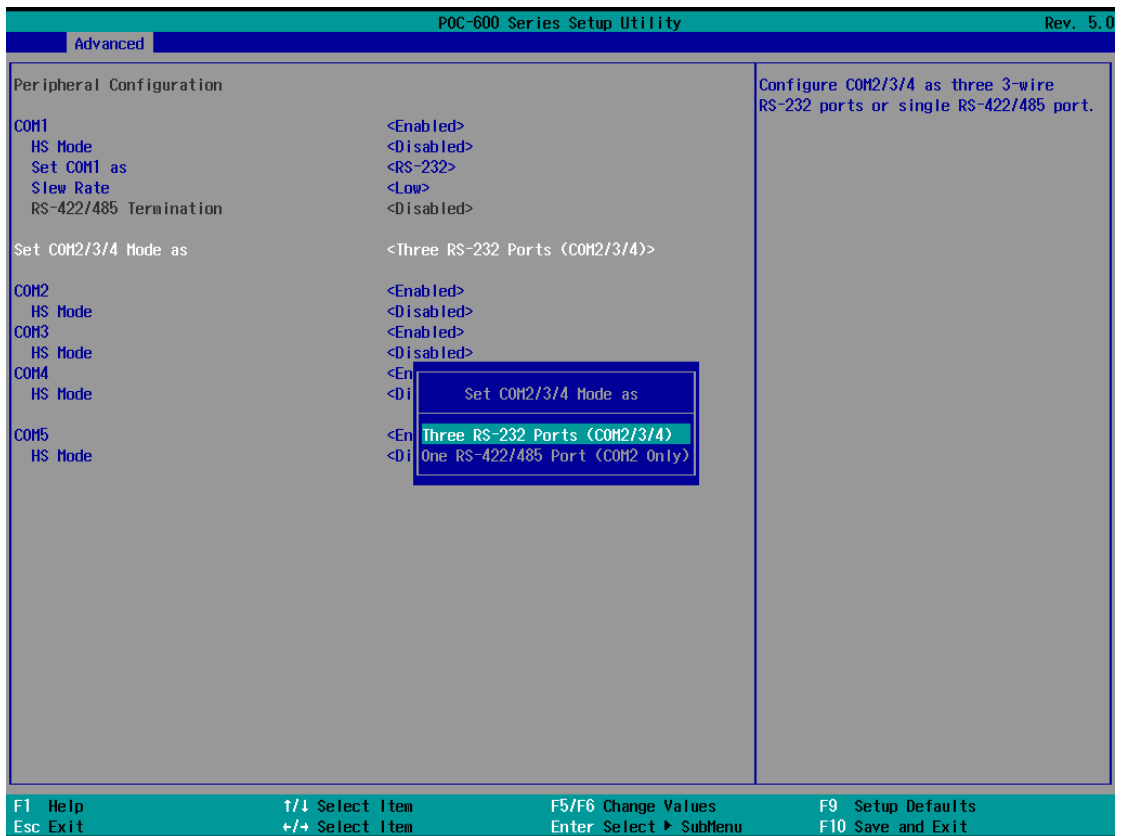

To set COM2/ 3/ 4 operating mode:

1. Press **F2** when the system boots up to enter the BIOS setup utility.
2. Go to **[Advanced]** → **[Peripheral Configuration]**.
3. Set the **[Set COM2/ 3/ 4 Mode as]** option to the desired mode.
4. Once set, press **F10** to save setting and exit.

4.3 TPM Availability

Trusted Platform Module (TPM) is a hardware-based cryptoprocessor to secure hardware by integrating cryptographic keys into devices. The system is designed with on-board TPM 2.0 module. As TPM 2.0 requires 64-bit Windows 10 with UEFI boot mode, it is enabled in BIOS by default.



To enable TPM availability:

1. When system boots up, press F2 to enter BIOS setup utility.
2. Go to **[Security] > [TPM Availability]**, press ENTER to bring up Options, Available/ Hidden.
3. Highlight your selection, press Enter and press F10 to “Exit Saving Changes”.

4.4 C-States

C-States is a power-saving technique implemented in modern Intel processors. It shuts down the clock signals and power for idle logic units inside the CPU to save the energy consumed. The trade-off, however, is a longer latency for CPU to wake up and be 100% operational. Depending on your application, you can configure these options to have higher performance (disable “C-States”) or lower power-consumption (enable “C-States”).

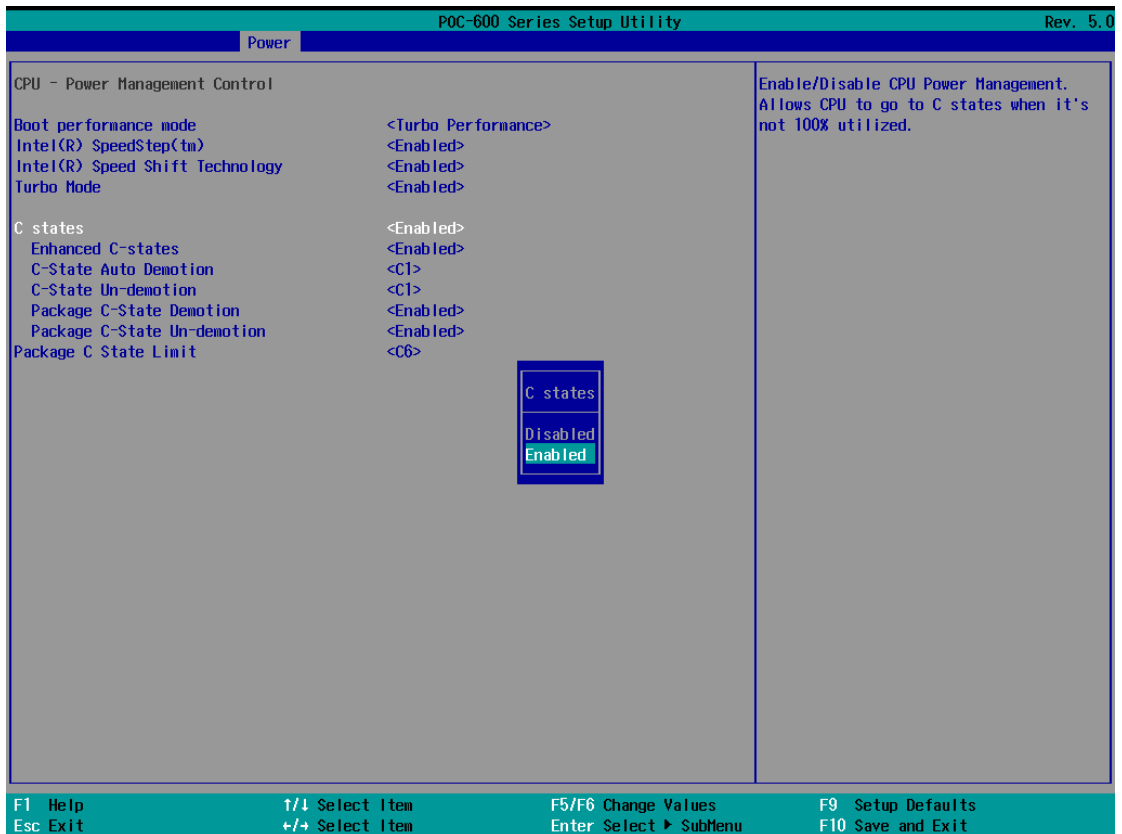

To set C-States and Enhanced C-States:

1. Press **F2** when the system boots up to enter the BIOS setup utility.
2. Go to **[Power] → [CPU Configuration] → [CPU Power Management]**
3. Enable/disable the **[C-States]** option according to your application.
4. Once set, press **F10** to save setting and exit.

4.5 Power over Ethernet (POC-600 Only)

The Power over Ethernet (PoE) functionality is available on following ports, and it allows for the transmission of data and power delivery while utilizing a single Cat5 and higher grade Ethernet cable.

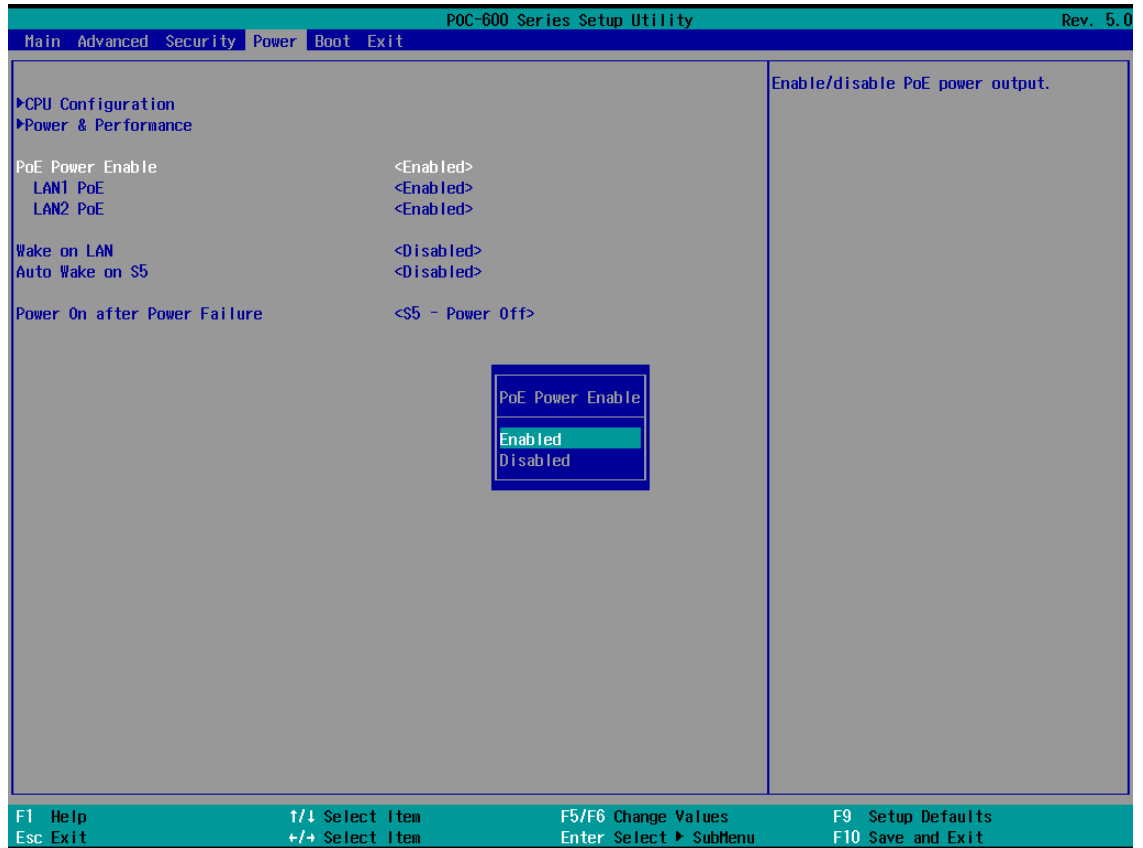

To enable/disable “PoE Power Enable” option:

1. Press **F2** when the system boots up to enter the BIOS setup utility.
2. Go to **[Power]**.
3. You may enable/disable the **[PoE Power Enable]** option.

4. When enabled, each port can be enabled or disabled independently.

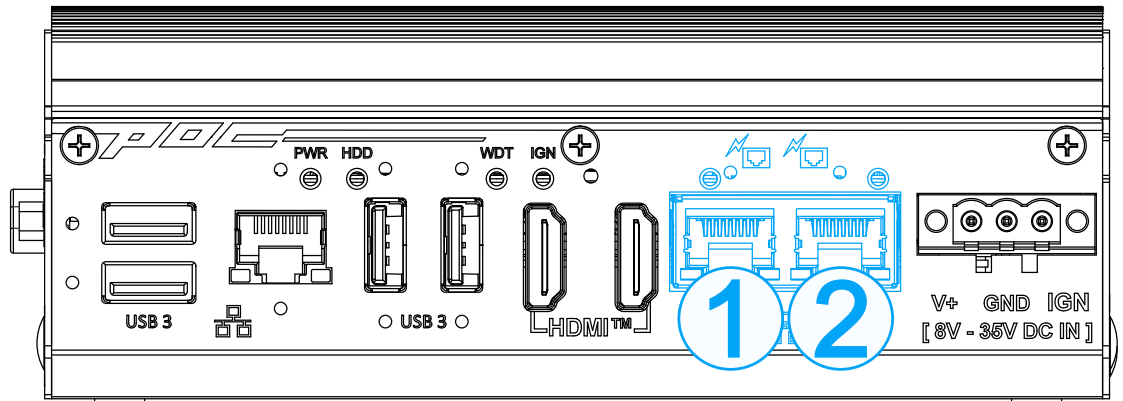

5. Once set, press **F10** to save setting and exit.

4.6 Wake-on-LAN

Wake-on-LAN (WOL) is a mechanism which allows you to turn on your system via Ethernet connection. To utilize Wake-on-LAN function, you have to enable this option first in BIOS settings. Please refer to Powering on via Wake-on-LAN function.

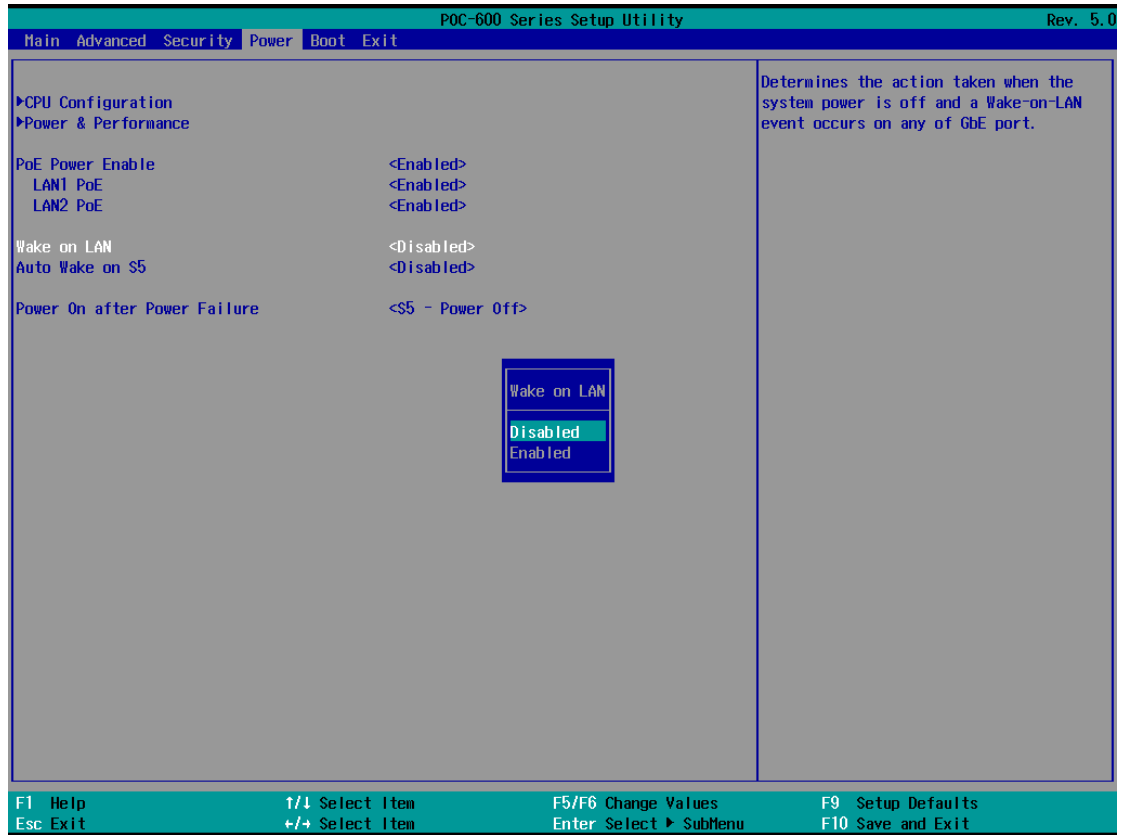

To enable/disable “Wake on LAN” option:

1. Press **F2** when the system boots up to enter the BIOS setup utility.
2. Go to **[Power]**.
3. You may enable/disable the **[Wake on LAN]** option.
4. Once set, press **F10** to save setting and exit.

4.7 Power On after Power Failure

This option defines the system's behavior when DC power is supplied.

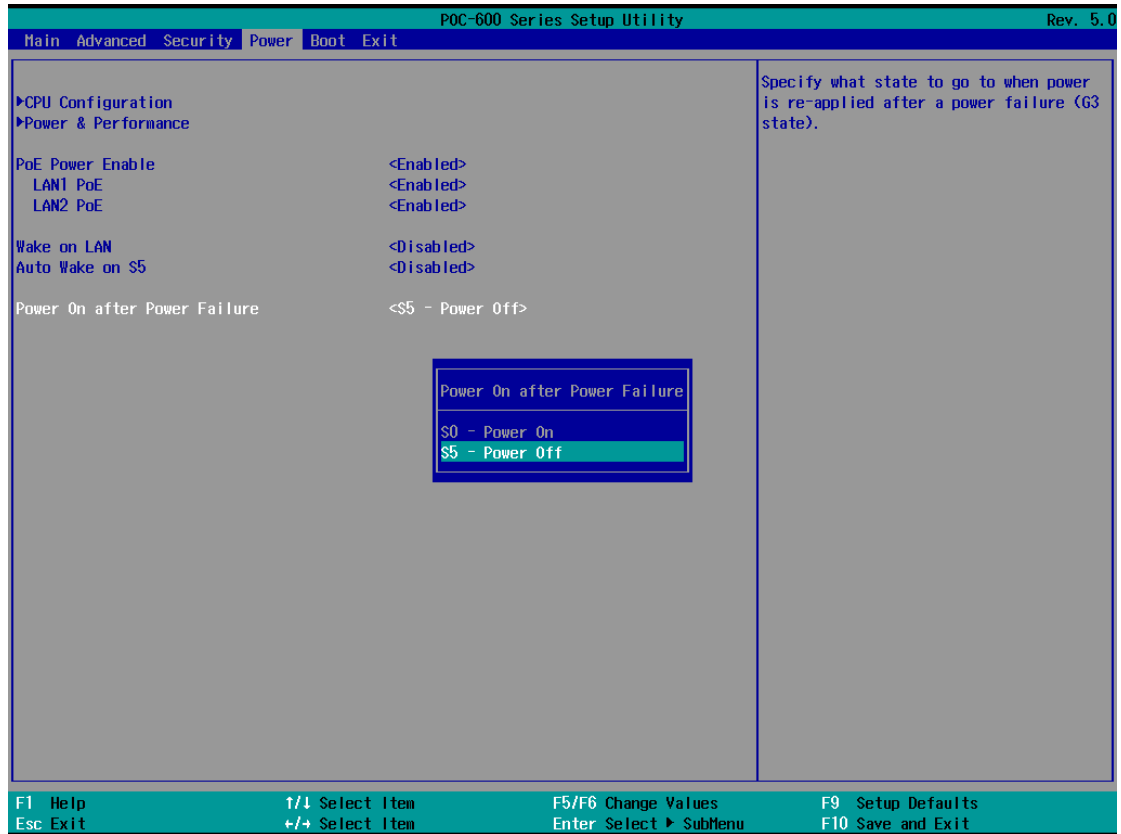

Value	Description
S0 – Power On	System is powered on when DC power is supplied.
S5 – Power Off	System is kept in off state when DC power is supplied.

When you want to use the AT-mode remote on/off control function, you have to set this option to “S0 – Power On”. Please refer to [section 3.7.2](#) for instructions of using AT-mode remote on/off control function.

To set “Power On after Power Failure” option:

1. Press **F2** when the system boots up to enter the BIOS setup utility.
2. Go to **[Power]**.
3. Set the **[Power On after Power Failure]** option to the desired setting.
4. Once set, press **F10** to save setting and exit.

4.8 Boot Menu

The Boot menu in BIOS allows you to specify the system’s boot characteristics by setting bootable device components (boot media) and method. Or, you may press F12 upon system start up and select a device you wish boot from.

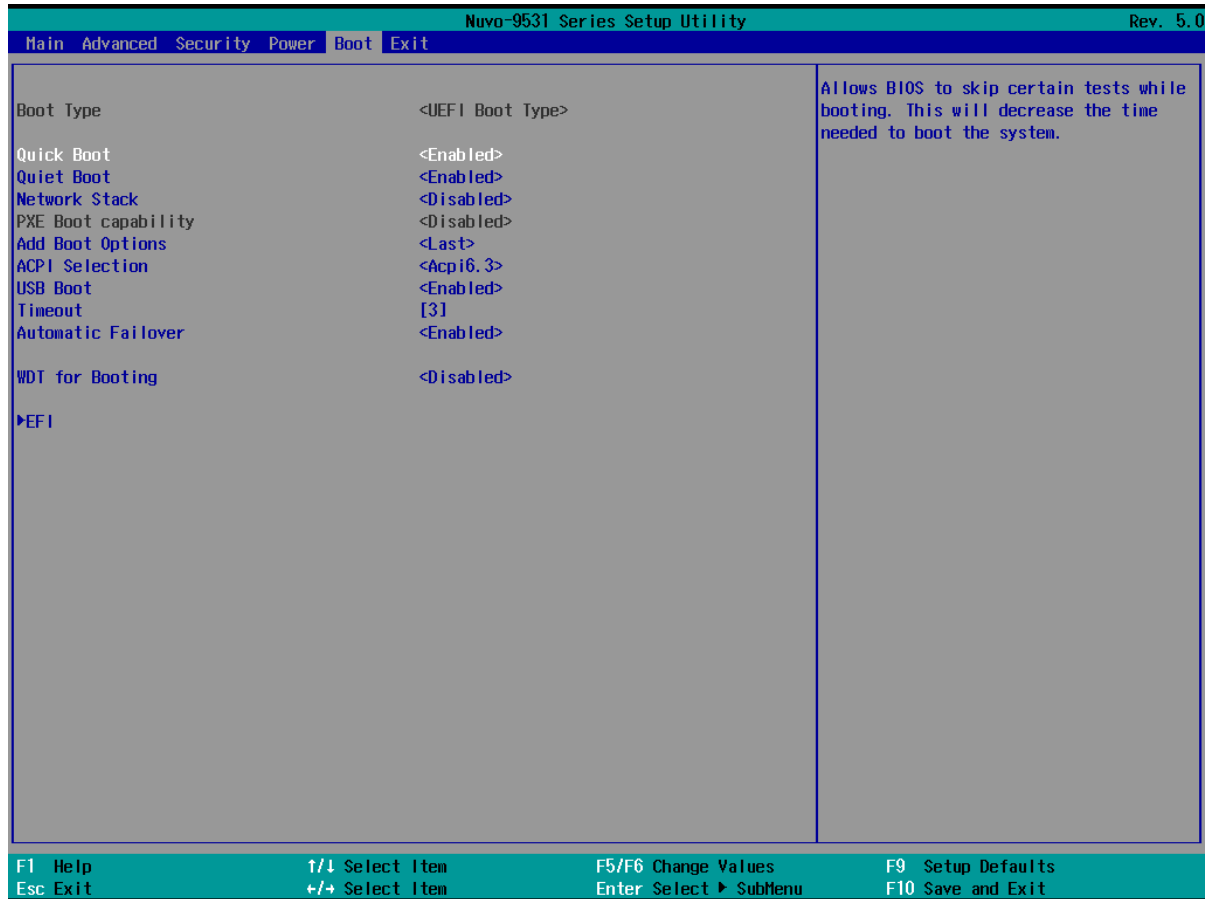

Value	Option	Description
Boot Type	UEFI Boot Type	Only UEFI boot media listed are approved as boot media.
Quick Boot	Enabled	The system starts up faster because BIOS skips various hardware function tests
	Disabled	The system starts up slower because BIOS goes through various hardware functions tests
Network Stack	Enabled	The system is available for network access using UEFI.
	Disabled	The system is not available for network access using UEFI.
PXE Boot capability	Disabled	The BIOS does not initialize the PXE option ROM
	Enabled	The BIOS/UEFI will initialize the Intel Boot Agent for each I226-IT NIC.

Add Boot Options	First	Newly detected boot media are placed at the top of the boot order.
	Last	Newly detected boot media are placed at the bottom of the boot order.
ACPI Selection	1.0B/ 3.0/ 4.0/ 5.0/ 6..3	Advanced Configuration and Power Interface allows the operating system to control system power management
USB Boot	Enabled	Allow boot from bootable USB devices.
	Disabled	Does not allow boot from bootable USB devices
Timeout	1, 2, 3, etc (in seconds)	Boot delay time in seconds to give the user time to activate the hotkey to access the BIOS
Automatic Failover	Enabled	Automatically checks for the next bootable device when the set default device fails.
	Disabled	Will only boot from the designated device.
WDT for booting	Disabled, 1, 3, 5, 10 (minutes)	WDT ensures a successful system boot by specifying a timeout value
EFI	NA	Extensible Firmware Interface

4.9 Position New Boot Device

The “Add Boot Options” allow you to determine whether a newly added device (eg. USB flash disk) is to boot as the first device to boot or the last in the boot sequence.

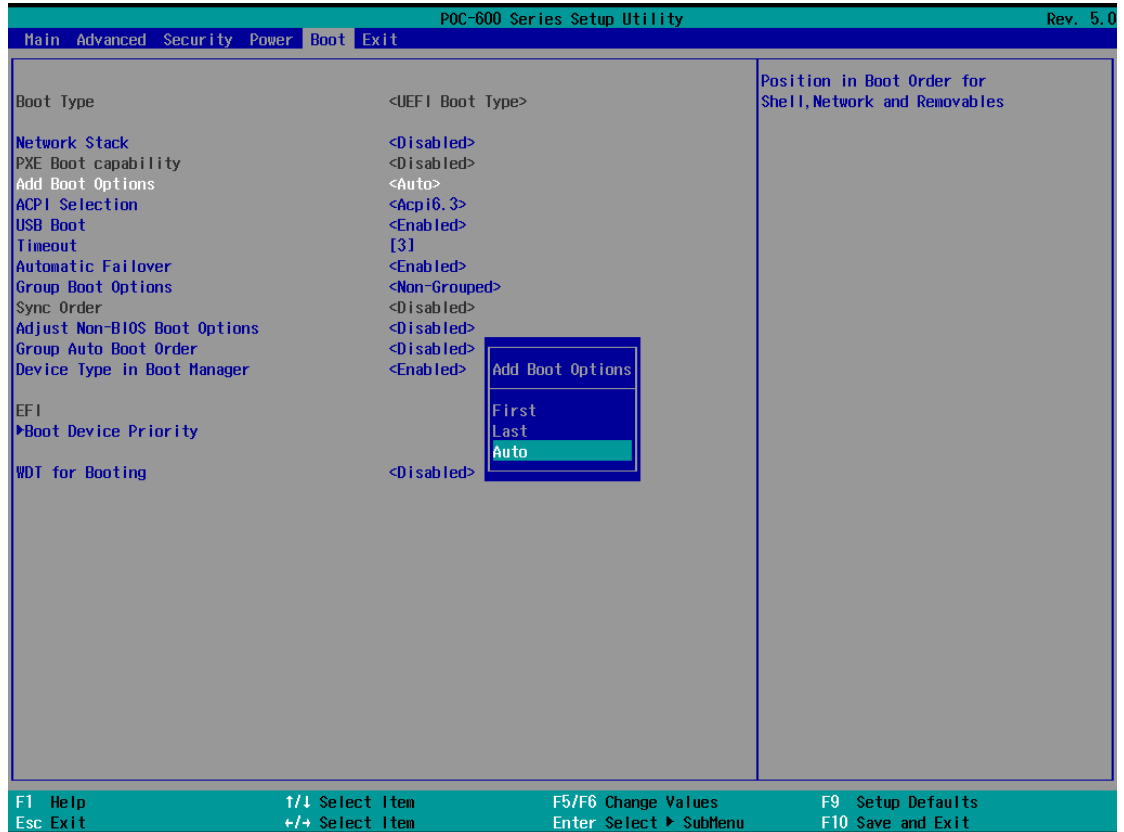

To set the newly-installed boot device as the first or last boot device:

1. Press **F2** when the system boots up to enter the BIOS setup utility.
2. Go to **[Boot] > [Add Boot Options]** menu.
3. Select **[First]** or **[Last]** for your newly-added boot device and press Enter.
4. Once set, press **F10** to save setting and exit.

4.10 Watchdog Timer

The watchdog timer secures the boot process by means of a timer. Once the timer expires, a reset command is issued to initiate another booting process. There are two options in BIOS menu, “*Automatically after POST*” and “*Manually after Entering OS*”. When “*Automatically after POST*” is selected, the BIOS automatically stops the watchdog timer after POST (Power-On Self Test) OK. When “*Manually after Entering OS*” is selected, the user must stop the watchdog timer once booted into the OS. This guarantees the system can always boot into the OS, otherwise another booting process will be initiated. For information about programming watchdog timer, please refer to [Appendix A Using WDT & DIO](#).

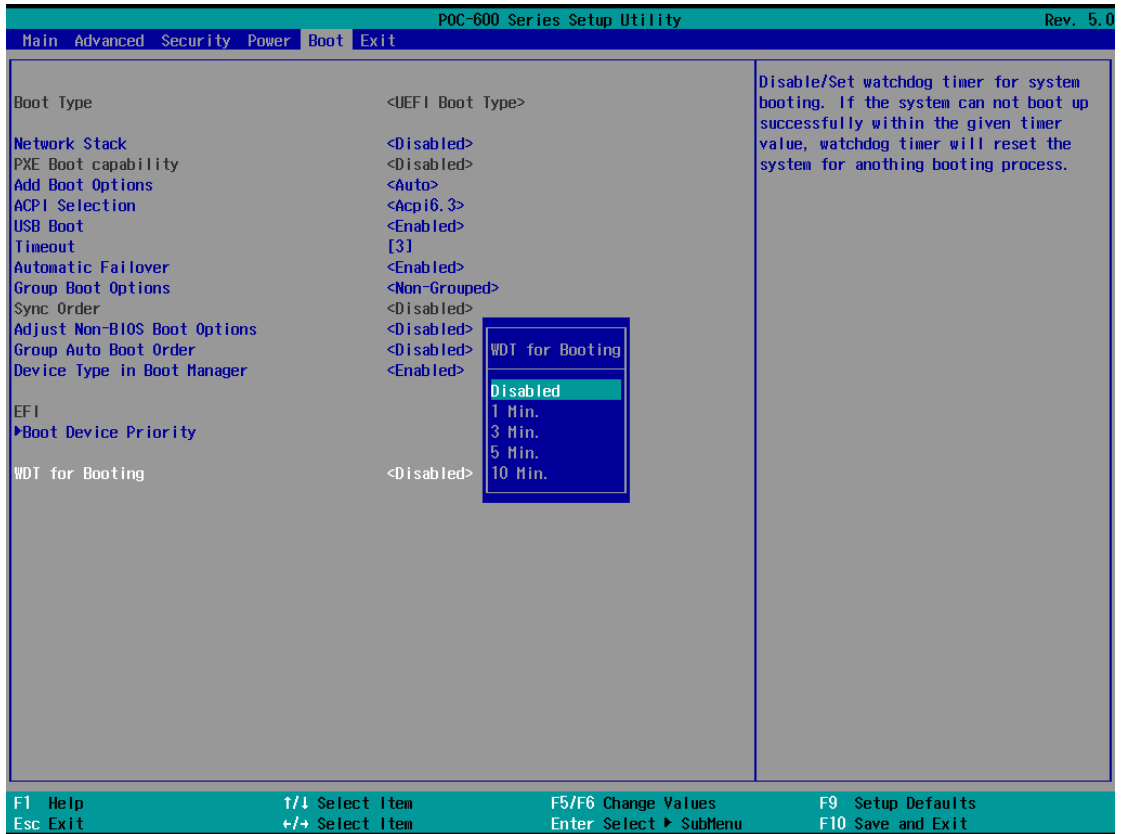

To set the watchdog timer for boot in BIOS:

1. Press **F2** when the system boots up to enter the BIOS setup utility.
2. Go to **[Boot]** menu.
3. Disable or select timeout value for **[WDT for Booting]** option.
4. Once you set a timeout value, the **[WDT Stop Option]** option appears. You can select either “*Automatically after POST*” or “*Manually after Entering OS*”.
5. Once set, press **F10** to save setting and exit.

5 OS Support and Driver Installation

5.1 Operating System Compatibility

POC-600 series only provide driver support for the following operating systems. The following list contains the operating systems which have been tested in Neosys Technology Inc.

- Microsoft Windows 10 LTSC 21H2
- Microsoft Windows 11 LTSC 24H2
- Ubuntu 22.04.2 LTS or other distribution with kernel version ≥ 5.19 */**



NOTE

**For Linux system, user may need to manually compile and install the driver for Intel graphics or I226 controller if the driver is not embedded in kernel. You can visit Intel website for further information.*

***For distributions, graphics driver may not be completely implemented in its kernel. You may encounter restrictions when using these features, such as multiple independent displays. For optimum operation, it is the users' responsibility to manually check for new drivers and upgrades!*

Neosys may remove or update operating system compatibility without prior notice. Please contact us if your operating system of choice is not on the list.

5.2 Driver Installation

The system drivers are available online, please click on this [link](#) to download the drivers.

5.3 Driver for Watchdog Timer and DIO

Neosys provides a driver package which contain function APIs for Watchdog Timer control function. You should install the driver package (WDT_DIO_Setup.exe) in prior to use these functions. Please download the latest version of WDT_DIO_Setup.exe to ensure compatibility.

Please refer to this [link](#) to download WDT_DIO.

Appendix A Using WDT & DIO

The watchdog timer (WDT) function ensures reliable system operation. The WDT is a hardware mechanism to reset the system if the watchdog timer is expired. Users can start the WDT and keeping resetting the timer to make sure the system or program is running. Otherwise, the system shall be reset.

In this section, we'll illustrate how to use the function library provided by Neosys to program the WDT functions. Currently, WDT driver library supports Windows 10 x64 and WOW64 platform. For other OS support, please contact Neosys Technology for further information.

Installing WDT_DIO Library

The WDT_DIO function library is delivered in the form of a setup package named **WDT_DIO_Setup.exe**. In prior to program WDT, you should execute the setup program and install the WDT library. Please use the following WDT_DIO_Setup packages according to your operating systems and application.



NOTE

Please download from Neosys website and install the latest WDT_DIO_Setup.exe file.

WDT and DIO Library Installation

WDT_DIO_Setup.2.4.0.0.exe will be used as an example to demonstrate WDT & DIO Library installation setup process. Please refer to the instructions below.

1. Execute **WDT_DIO_Setup.2.4.0.0.exe**.

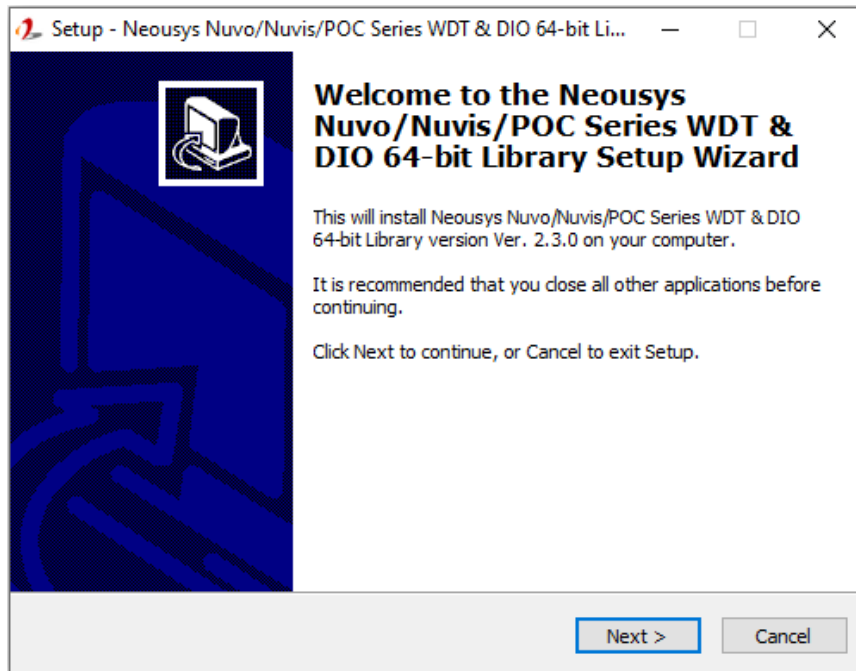

2. Click "Next >" and specify the directory of installing related files. The default directory is *C:\Neosys\WDT_DIO*.

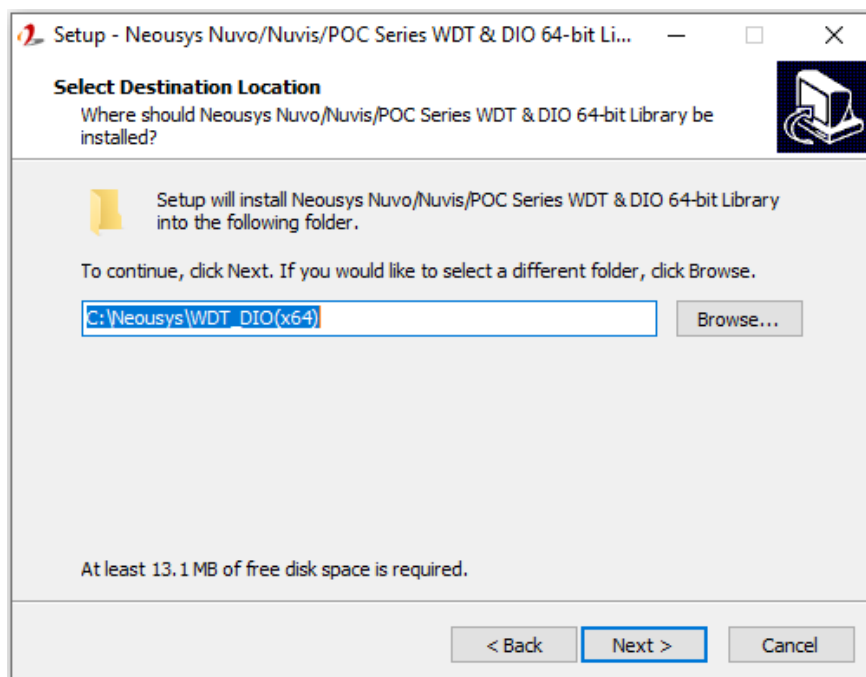

- Once the installation has finished, a dialog will appear to prompt you to reboot the system. The WDT & DIO library will take effect after the system has rebooted.

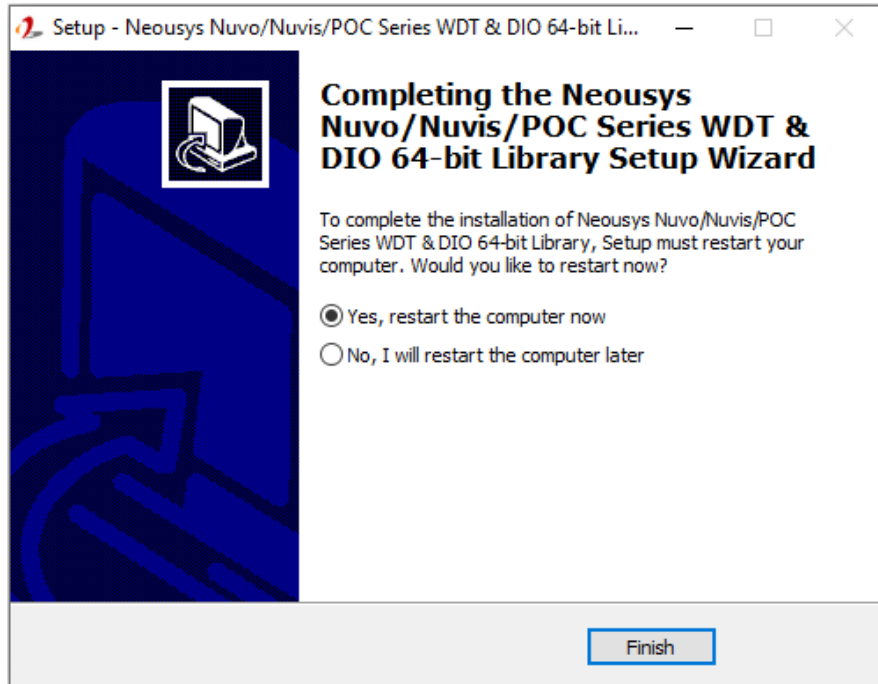

- When programming your WDT or DIO program, the related files are located in

Header File:	\Include
Library File:	\Lib
Function Reference:	\Manual
Sample Code:	\Sample\WDT_Demo (Demo for Watchdog Timer) \Sample\DIO_Demo (Demo for isolated DIO Control) \Sample\COS_Demo (Demo for change-of-state DI)

WDT Function Reference

InitWDT

Syntax	BOOL InitWDT(void);
Description:	Initialize the WDT function. You should always invoke InitWDT() before set or start watchdog timer.
Parameter	None
Return Value	TRUE: Successfully initialized FALSE: Failed to initialize
Usage	BOOL bRet = InitWDT()

SetWDT

Syntax	BOOL SetWDT(WORD tick, BYTE unit);
Description	Set timeout value and unit for watchdog timer. When InitWDT() is invoked, a default timeout value of 255 seconds is assigned.
Parameter	<i>tick</i> WORD value (1 ~ 65535) to indicate timeout ticks. <i>unit</i> BYTE value (0 or 1) to indicate unit of timeout ticks. 0 : unit is minute 1: unit is second
Return Value	If value of unit is correct (0 or 1), this function returns TRUE, otherwise FALSE.
Usage	WORD tick=255; BYTE unit=1; //unit is second. BOOL bRet = SetWDT(tick, unit); //timeout value is 255 seconds

StartWDT

Syntax	BOOL StartWDT(void);
Description	Starts WDT countdown. Once started, the WDT LED indicator will begin blinking. If ResetWDT() or StopWDT is not invoked before WDT countdowns to 0, the WDT expires and the system resets.
Parameter	None
Return Value	If the timeout value is given in correct format (WDT started), this function returns TRUE, otherwise FALSE
Usage	BOOL bRet = StartWDT()

ResetWDT

Syntax	BOOL ResetWDT(void);
Description	Reset the timeout value to the value given by SetWDT().If ResetWDT() or StopWDT is not invoked before WDT countdowns to 0, the WDT expires and the system resets.
Parameter	None
Return Value	Always returns TRUE
Usage	BOOL bRet = ResetWDT()

StopWDT

Syntax	BOOL StopWDT(void);
Description	Stops the countdown of WDT. When WDT has stopped, the WDT LED indicator stops blinking.
Parameter	None
Return Value	Always returns TRUE
Usage	BOOL bRet = StopWDT()

DIO Functions

InitDIO

Syntax	BOOL InitDIO(void);
Description	Initialize the DIO function. You should always invoke InitDIO() before write/read any DIO port/channel.
Parameter	None
Return Value	Returns TRUE if initialization successes, FALSE if initialization failed.
Usage	BOOL bRet = InitWDT();

DIReadLine

Syntax	BOOL DIReadLine(BYTE ch);
Description	Read a single channel of isolated digital input.
Parameter	<i>ch</i> BYTE value specifies the DI channel to be read. <i>Ch</i> should be a value of 0 ~ 7.
Return Value	The status (TRUE or FALSE) of the specified DI channel.
Usage	BYTE ch=3; //DI channel #3 BOOL DIChValue = DIReadLine(ch); //read DI channel #3

DIReadPort

Syntax	WORD DIReadPort(void);
Description	Read the entire isolated digital input port (8 channels).
Parameter	None
Return Value	A WORD value (0~255) indicates the status of DI port (8 DI channels).
Usage	WORD DIPortValue = DIReadPort ();

DOWriteLine

Syntax	void DOWriteLine(BYTE ch, BOOL value);
Description	Write a single channel of isolated digital output.
Parameter	<p>ch BYTE value specifies the DO channel to be written. <i>Ch</i> should be a value of 0 ~ 7.</p> <p>value BOOL value (TRUE or FALSE) specifies the status of DO channel.</p>
Return Value	None
Usage	<pre> BYTE ch=3; //DI channel #3 BOOL DOChValue=TRUE; DOWriteLine(ch, DOChValue); //write DO channel #3 as TRUE </pre>

DOWritePort

Syntax	void DOWritePort(WORD value);
Description	Write the entire isolated digital output port (8 channels).
Parameter	<p>value WORD value specifies the status of the DO port. <i>Value</i> should be a value of 0~255.</p>
Return Value	None
Usage	<pre> WORD DOPortValue=0XFF; //11111111b DOWritePort(DOPortValue); //write DO port as 11111111b </pre>

Appendix B PoE On/ Off Control

The system offers two 802.3at PoE+ ports with a unique feature to allow users manually turn on or off the power supply of each PoE port. This can be function can be useful in power device (PD) fault-recovery or power reset.

The function APIs are encapsulated in Neousys WDT_DIO driver package. Please follow the instructions in [Appendix A Watchdog Timer & Isolated DIO](#) to install the driver package prior to programming PoE on/off control function

PoE On/ Off Control Function Reference

GetStatusPoEPort

Syntax	BYTE GetStatusPoEPort (Byte port);
Description	Get current on/off status of designated PoE port.
Parameter	<i>port</i> BYTE value specifies the index of PoE port. Please refer to the following illustration, <i>port</i> should be a value of 1 - 2.
Return Value	BYTE value indicating PoE on/off status 0 if port is disabled (off) 1 if port is enabled (on)
Usage	BYTE bEnabled = GetStatusPoEPort (1); //Get on/off status of PoE Port#1

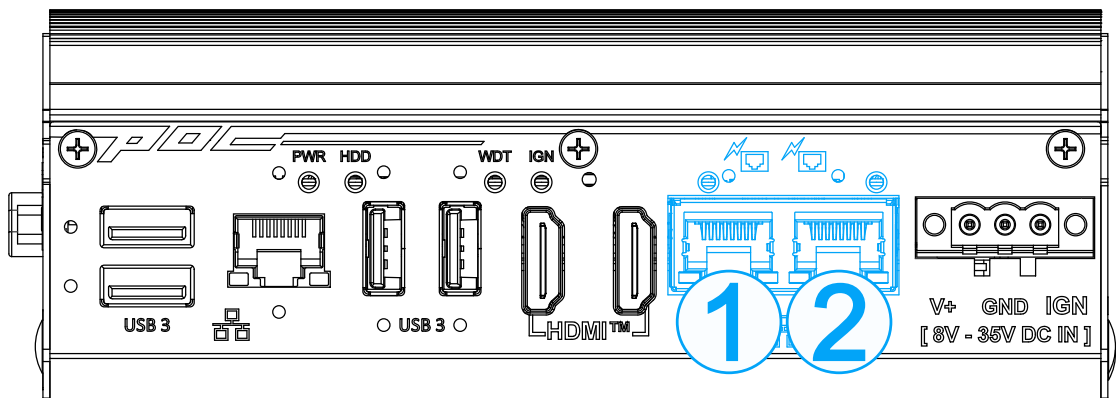

EnablePoEPort

Syntax	BOOL EnablePoEPort (BYTE port);
Description	Turn on PoE power of designated PoE port.
Parameter	<p><i>port</i></p> <p>BYTE value specifies the index of PoE port. Please refer to the following illustration, <i>port</i> should be a value of 1 - 2</p>
Return Value	<p>TRUE if enabled success</p> <p>FALSE if fail to enable.</p>
Usage	BOOL bRet = EnablePoEPort (1); //Turn on PoE Port#1

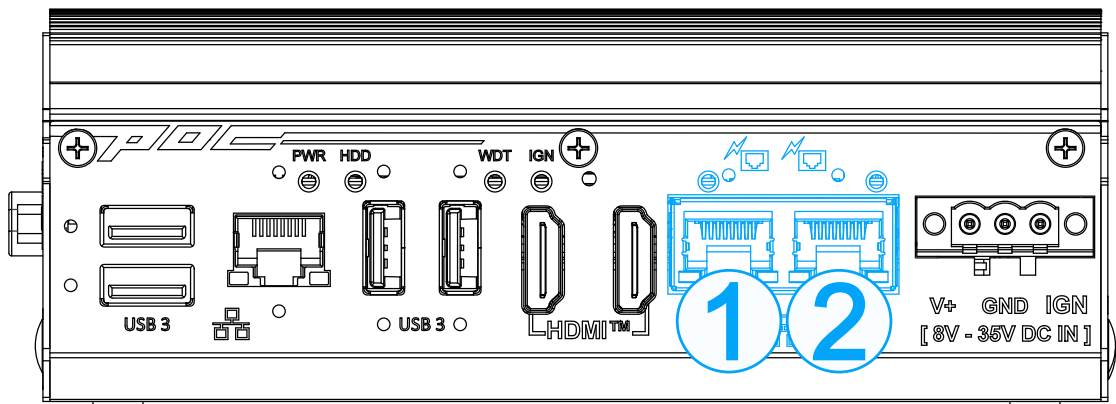

DisablePoEPort

Syntax	BOOL DisablePoEPort (BYTE port);
Description	Turn off PoE power of designated PoE port
Parameter	<p><i>port</i></p> <p>BYTE value specifies the index of PoE port. Please refer to the following illustration, <i>port</i> should be a value of 1 - 2</p>
Return Value	<p>TRUE if disabled success</p> <p>FALSE if fail to disable</p>
Usage	BOOL bRet = DisablePoEPort (1); //Turn off PoE Port#1

