

Neousys Technology Inc.

POC-766AWP Series

User Manual

Revision 1.1

Table of Contents

Table of Contents	2
Legal Information	4
Contact Information	5
Declaration of Conformity	5
Copyright Notice	6
Safety Precautions	7
Mesures de sécurité	8
Service and Maintenance	9
Avertissement concernant les piles	9
Hot Surface Warning	10
Surface chaude	10
Battery Warning	11
Entretien et réparation	11
ESD Precautions	12
Précautions nécessaires de décharge électrostatique (ESD)	12
Restricted Access Location	13
Lieu d'accès restreint	13
About This Manual	14

1 Introduction

1.1 POC-766AWP Specifications	16
1.2 POC-766AWP-DEV Specifications	18
1.3 Dimension	20
1.3.1 Superior View	20
1.3.2 M12 IO Panel View	21
1.3.3 IO Panel View	21
1.3.4 Bottom View	22
1.4 POC-766AWP Mounting Options	23
1.4.1 Wall Mount	23
1.4.2 Flattop Design Mount	23
1.4.3 DIN-Rail Mount Clip (Optional)	24

2 System Overview

2.1 Unpacking the System	25
2.1.1 POC-766AWP	25
2.1.2 POC-766AWP-DEV	25
2.2 POC-766AWP Series Front Panel	26
2.2.1 M12 A-coded Isolated COM Port	27
2.2.2 M12 A-coded CAN bus & DIO	28
2.2.3 M12 X-coded 2.5Gb Ethernet Port	29
2.2.4 M12 A-coded DC-in Port	30
2.3 POC-766AWP Power Button & Clear CMOS	31
2.4 POC-766AWP-DEV I/O Panel	32
2.4.1 USB 3.2 Gen 1 Port (POC-766AWP-DEV)	33
2.4.2 HDMI™ Port (POC-766AWP-DEV)	34
2.4.3 Power Button & Clear CMOS (POC-766AWP-DEV)	35
2.4.4 SMA Antenna Opening (POC-766AWP-DEV)	36
2.5 POC766AWP Series Internal I/O	37
2.5.1 SO-DIMM Memory Socket	37
2.5.2 M.2 2280 M Key	38
2.5.3 mini-PCIe Slot	40

3 System Installation

3.1 Disassembling the System Enclosure	43
3.2 Installing Internal Components	44

3.2.1	SO-DIMM Installation	44
3.2.2	M.2 2280 M Key Module Installation	47
3.2.3	mini-PCIe Module Installation	50
3.3	Installing the System Enclosure	53
3.4	Installing POC-766AWP Panel	55
3.5	Wall Mount Installation	58
3.5.1	Standard Wall Mount	58
3.5.2	Flattop Heatsink Mount	59
3.6	DIN Rail Installation	60
3.7	Powering On the System	62
3.7.1	Powering On Using the Power Button	62
3.7.2	Powering On Using Wake-on-LAN	63
3.7.3	Remote Switch Mode	65
3.8	Ignition Power Control	67
3.8.1	Principles of Ignition Power Control	67
3.8.2	Additional Features of Ignition Power Control	68
3.8.3	Wiring Ignition Signal	69
3.8.4	Configure your Windows system	70

4 BIOS Settings

4.1	COM1 Port Configuration	72
4.2	TPM Availability	74
4.3	C-States	75
4.4	Wake-on-LAN	76
4.5	Ignition Power Control	77
4.6	Auto Wake on S5	81
4.7	Boot Menu	82
4.8	Add Boot Options (Position New Boot Device)	84
4.9	Watchdog Timer	85

5 OS Support and Driver Installation

5.1	Operating System Compatibility	86
5.2	Driver Installation	87
5.3	Driver for Watchdog Timer and DIO	87

Appendix A Using WDT & DIO

WDT and DIO Library Installation	89
WDT Function Reference	91
InitWDT	91
SetWDT	91
StartWDT	92
ResetWDT	92
StopWDT	92
DIO Functions	93
InitDIO	93
DIReadLine	93
DIReadPort	93
DOWriteLine	94
DOWritePort	94

Legal Information

All Neosys Technology Inc. products shall be subject to the latest Standard Warranty Policy

Neosys Technology Inc. may modify, update or upgrade the software, firmware or any accompanying user documentation without any prior notice. Neosys Technology Inc. will provide access to these new software, firmware or documentation releases from download sections of our website or through our service partners.

Before installing any software, applications or components provided by a third party, customer should ensure that they are compatible and interoperable with Neosys Technology Inc. product by checking in advance with Neosys Technology Inc. Customer is solely responsible for ensuring the compatibility and interoperability of the third party's products. Customer is further solely responsible for ensuring its systems, software, and data are adequately backed up as a precaution against possible failures, alternation, or loss.

For questions in regards to hardware/ software compatibility, customers should contact Neosys Technology Inc. sales representative or technical support.

To the extent permitted by applicable laws, Neosys Technology Inc. shall NOT be responsible for any interoperability or compatibility issues that may arise when (1) products, software, or options not certified and supported; (2) configurations not certified and supported are used; (3) parts intended for one system is installed in another system of different make or model.

Contact Information

For contact information, please visit our [official website](#).

Declaration of Conformity

FCC

This equipment has been tested and found to comply with the limits for a Class A digital device, pursuant to part 15 of the FCC Rules. These limits are designed to provide reasonable protection against harmful interference when the equipment is operated in a commercial environment. This equipment generates, uses, and can radiate radio frequency energy and, if not installed and used in accordance with the instruction manual, may cause harmful interference to radio communications. Operation of this equipment in a residential area is likely to cause harmful interference in which case the user will be required to correct the interference at own expense.

CE

The product(s) described in this manual complies with all applicable European Union (CE) directives if it has a CE marking. For computer systems to remain CE compliant, only CE-compliant parts may be used. Maintaining CE compliance also requires proper cable and cabling techniques.

Copyright Notice

All rights reserved. This publication may not be reproduced, transmitted, transcribed, stored in a retrieval system, or translated into any language or computer language, in any form or by any means, electronic, mechanical, magnetic, optical, chemical, manual or otherwise, without the prior written consent of Neosys Technology, Inc.

Disclaimer

This manual is intended to be used as an informative guide only and is subject to change without prior notice. It does not represent commitment from Neosys Technology Inc. Neosys Technology Inc. shall not be liable for any direct, indirect, special, incidental, or consequential damages arising from the use of the product or documentation, nor for any infringement on third party rights.

Patents and Trademarks

Neosys, the Neosys logo, Expansion Cassette, MezIO™ are registered patents and trademarks of Neosys Technology, Inc.

Windows is a registered trademark of Microsoft Corporation.

Intel®, Core™ are registered trademarks of Intel Corporation

NVIDIA®, GeForce® are registered trademarks of NVIDIA Corporation

All other names, brands, products or services are trademarks or registered trademarks of their respective owners.

Safety Precautions

- Read these instructions carefully before you install, operate, or transport the system.
- Install the system or DIN rail associated with, at a sturdy location
- Install the power socket outlet near the system where it is easily accessible
- Secure each system module(s) using its retaining screws
- Place power cords and other connection cables away from foot traffic. Do not place items over power cords and make sure they do not rest against data cables
- Shutdown, disconnect all cables from the system and ground yourself before touching internal modules
- Ensure that the correct power range is being used before powering the device
- Should a module fail, arrange for a replacement as soon as possible to minimize down-time
- By means of a power cord connected to a socket-outlet with earthing connection
- This product is intended to be supplied by a Listed Power Adapter or DC power source, rated 8V DC, 5A - 35V DC, 1.2A, Tma 70 degree C and 2000m altitude during operation. If further assistance is required, please contact Neousys Technology
- If the system is not going to be used for a long time, disconnect it from mains (power socket) to avoid transient over-voltage

Mesures de sécurité

- Lire attentivement ces directives avant d'installer, d'utiliser ou de transporter le système.
- Installer le système ou la barrette DIN qui lui est associée, à un endroit solide
- Installer la prise de courant près du système et pour qu'elle soit facilement accessible
- Fixer chaque module du système à l'aide de ses vis de fixation
- Éloigner de la circulation piétonne les cordons d'alimentation et autres câbles de connexion. Ne jamais placer d'objets sur les cordons d'alimentation et s'assurer qu'ils ne reposent pas contre les câbles de données
- Avant de toucher les modules internes, arrêter, débrancher tous les câbles du système et raccordez-vous à la terre
- S'assurer que la bonne plage de puissance est utilisée avant d'alimenter l'appareil
- Prévoir un remplacement dès que possible en cas de défaillance d'un module, afin de minimiser les temps d'arrêt
- Au moyen d'un cordon d'alimentation branché à une prise de courant avec mise à la terre (MALT)
- Ce produit doit être alimenté par un adaptateur de courant homologué ou une source d'alimentation CC, 8V DC, 5A - 35V DC, et 1.2 A, conçue pour fonctionner à 70 °C Tma et à 2 000 m d'altitude. Communiquer avec Neosys Technology si de l'assistance supplémentaire est requise
- Si le système ne sera pas être utilisé pendant une période prolongée, le débrancher du réseau (prise de courant) pour éviter une surtension transitoire

Service and Maintenance

- ONLY qualified personnel should service the system
- Shutdown the system, disconnect the power cord and all other connections before servicing the system
- When replacing/ installing additional components (expansion card, memory module, etc.), insert them as gently as possible while assuring proper connector engagement

Avertissement concernant les piles

- Les piles risquent d'exploser si elles sont mal installées.
- Ne jamais essayer de recharger, d'ouvrir de force ou de chauffer les piles.
- Remplacer les piles uniquement avec le même type ou l'équivalent recommandé par le fabricant.

Hot Surface Warning



HOT SURFACE. DO NOT TOUCH. "ATTENTION: Surface chaude. Ne pas toucher."

WARNING!

Components/ parts inside the equipment may be hot to touch!

Please wait one-half hour after switching off before handling parts.

Surface chaude

AVERTISSEMENT : *SURFACE CHAUDE. NE PAS TOUCHER.*

Les composants et pièces à l'intérieur de l'équipement peuvent être chauds au toucher. Après l'arrêt, attendre au moins 30 minutes pour que le système refroidisse avant d'effectuer l'entretien.

- Respecter les règles de sécurité et d'entretien mentionnées au début du guide d'utilisation!

Battery Warning

Caution!



- Batteries are at risk of exploding if incorrectly installed
- Do not attempt to recharge, force open, or heat the battery
- Replace the battery only with the same or equivalent type recommended by the manufacturer

Entretien et réparation

- La réparation du système ne peut être effectuée que par du personnel qualifié
- Avant de réparer le système, arrêter le système, débrancher le cordon d'alimentation et toutes les autres connexions
- Lors du remplacement ou de l'installation de composants supplémentaires (carte d'extension, module de mémoire, etc.), les insérer le plus doucement possible tout en s'assurant que les connecteurs sont bien engagés jusqu'au bout

ESD Precautions

- Handle add-on module, motherboard by their retention screws or the module's frame/ heat sink. Avoid touching the PCB circuit board or add-on module connector pins
- Use a grounded wrist strap and an anti-static work pad to discharge static electricity when installing or maintaining the system
- Avoid dust, debris, carpets, plastic, vinyl and styrofoam in your work area.
- Do not remove any module or component from its anti-static bag before installation

Précautions nécessaires de décharge électrostatique (ESD)

- Tenir le module complémentaire et la carte mère par leurs vis de rétention ou le châssis/dissipateur de chaleur du module. Éviter de toucher la carte de circuit imprimé ou les broches du connecteur du module complémentaire
- Afin de décharger l'électricité statique, utiliser une dragonne mise à la terre et un tapis de travail antistatique lors de l'installation ou de l'entretien du système
- Éviter la poussière, les débris, les tapis, le plastique, le vinyle et la mousse de polystyrène dans votre zone de travail.
- Ne retirer aucun module ou composant de son sac antistatique avant l'installation

Restricted Access Location

The controller is intended for installation only in certain environments where both of the following conditions apply:

- Access can only be gained by QUALIFIED SERVICE PERSONNEL who have been instructed on the reasons for restrictions applied to the location and any precautions that shall be taken
- Access is through the use of a TOOL, lock and key, or other means of security, and is controlled by the authority responsible for the location

Lieu d'accès restreint

Le contrôleur doit être installé uniquement dans les environnements où les deux conditions suivantes sont présentes :

- Le lieu ne peut être accédé que par du PERSONNEL TECHNIQUE QUALIFIÉ informé des raisons des restrictions appliquées à l'emplacement et des précautions à prendre

L'accès est contrôlé par l'autorité responsable de l'emplacement et se fait au moyen d'un OUTIL, d'une serrure et d'une clé ou d'autres moyens de sécurité

About This Manual

This manual introduces and demonstrates installation procedures of Neosys POC-766AWP series systems.

Revision History

Version	Date	Description
1.0	Dec. 2025	Initial release
1.1	Mar. 2026	Updated battery/ general warnings Updated screw torque range specifications Added high temperature warning label to packing list

1 Introduction

POC-766AWP is Neosys' new-generation AWP-series waterproof fanless embedded computer, featuring upgraded performance and enhanced rugged design. Powered by the Intel® i3-N305 processor and supporting DDR5 memory, it delivers a major boost in performance within a fully sealed IP67-rated enclosure. Built with stainless steel and aluminum, it provides two thermal solutions: direct-contact cooling inside metal cabinets and fanless cooling for standalone installation. POC-766AWP ensures reliable operation for demanding industrial and harsh-environment applications.

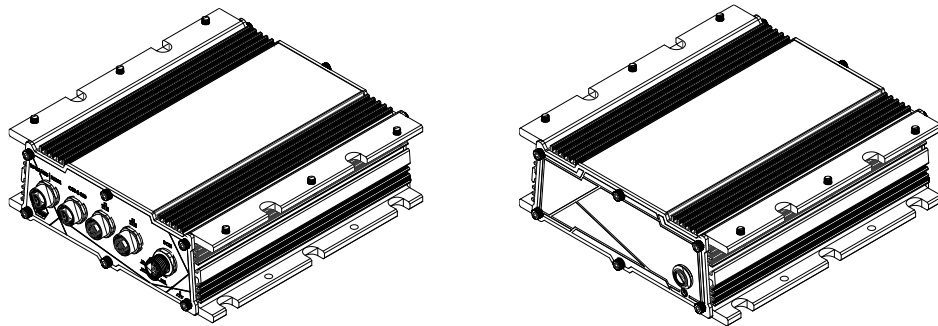

Engineered for industrial reliability, POC-766AWP features rugged I/O connectivity designed for demanding field environments. It provides dual 2.5GbE M12 X-coded connectors for secure, vibration-resistant Ethernet connections, as well as one isolated RS-232 and one isolated RS-422/485 port to ensure stable data transmission and protection against electrical surges. The system also supports CAN bus and isolated Digital IO, along with a MiniPCIe slot for wireless WiFi or LTE modules. Additionally, two internal USB 3.2 ports and one HDMI interface are available for use in non-waterproof environments, offering convenient access for system configuration or peripheral expansion.

POC-766AWP delivers IP67-level protection with an optimized balance between performance and cost. Its compact design and M12 connectivity guarantee protection against moisture, vibration, and dust, ensuring continuous operation in harsh environments. Designed for real-world durability and minimal maintenance, POC-766AWP is ideal for applications such as agriculture, industrial equipment, and industrial vehicles.

1.1 POC-766AWP Specifications

System Core				
Processor	Intel® Alder Lake Core™ i3-N305 processor (8C/8T, 1.8/3.8 GHz, 15W)			
Graphics	Integrated Intel® UHD Graphics with 32EUs			
Memory	1x DDR5-4800 SDRAM up to 16GB (one SODIMM socket)			
TPM	Supports dTPM 2.0			
Front I/O Interface				
Ethernet	2x 2.5Gb Ethernet ports by Intel® I226-IT via M12 X-coded, 8-pin			
Serial Port	1x isolated RS-232 port (COM1) and 1x isolated RS-422/485 ports (COM2) via M12 A-coded, 8-pin			
CAN Bus & DIO	1x isolated CAN 2.0B and 1-CH isolated DI and 2-CH isolated DO via M12 A-coded, 8-pin			
Rear I/O Interface (Must remove panel for access)				
USB	2x USB3.2 Gen2 x1 ports in type-A connectors			
Video Port	1x HDMI™ 1.4b, supporting 3840 x 2160 @ 30Hz			
Storage Interface				
M.2 M key	1x M.2 2280 M key socket (PCIe Gen3 x4) for NVMe SSD (supports SATA signal)			
Expansion Bus				
Mini-PCIe	1x full-size mini PCI Express socket with internal micro SIM socket			
Power Supply				
DC Input	8~35V DC input with ignition power control input via M12 A-coded, 5-pin connector			
Power Consumption				
Intel® i3-N305 (15W)		DC-in Voltage		
Status	C-States	12v	24v	35v
Standby				
Power Saving	Enabled	1.76W	2.23W	2.48W
	Disabled			
Idle	Enabled	10.53W	10.58W	10.6W
	Disabled			
Burnin PL1	Disabled	20.7W	21.3W	22.8W
Burnin PL2	Disabled	36.6W	37.42W	38.78W
Mechanical				

Dimension	161.5 mm (W) x 169 mm (D) x 52.7 mm (H)
Weight	1.8kg
Mounting	Wall-mount or DIN-rail mount (Optional)
Environmental	
Operating Temperature	-25°C to 70°C
Storage Temperature	-40°C to 85°C
Humidity	10% to 90% , non-condensing
Vibration	MIL-STD-810H, Method 514.8, Category 4
Shock	MIL-STD-810H, Method 516.8, Procedure I
EMC	CE/FCC Class A, according to EN 55032 & EN 55035
Safety	UL 62368-1, IEC 62368-1
Ingress Protection	IP67

1.2 POC-766AWP-DEV Specifications

System Core				
Processor	Intel® Alder Lake Core™ i3-N305 processor (8C/8T, 1.8/3.8 GHz, 15W)			
Graphics	Integrated Intel® UHD Graphics with 32EUs			
Memory	1x DDR5-4800 SDRAM up to 16GB (one SODIMM socket)			
TPM	Supports dTPM 2.0			
Front I/O Interface				
Ethernet	2x 2.5Gb Ethernet ports by Intel® I226-IT via M12 X-coded, 8-pin			
Serial Port	1x isolated RS-232 port (COM1) and 1x isolated RS-422/485 ports (COM2) via M12 A-coded, 8-pin			
CAN Bus & DIO	1x isolated CAN 2.0B and 1-CH isolated DI and 2-CH isolated DO via M12 A-coded, 8-pin			
Rear I/O Interface				
USB	2x USB3.2 Gen2 x1 ports in type-A connectors			
Video Port	1x HDMI™ 1.4b, supporting 3840 x 2160 @ 30Hz			
Storage Interface				
M.2 M key	1x M.2 2280 M key socket (PCIe Gen3 x4) for NVMe SSD (supports SATA signal)			
Expansion Bus				
Mini-PCIe	1x full-size mini PCI Express socket with internal micro SIM socket			
Power Supply				
DC Input	8~35V DC input with ignition power control input via M12 A-coded, 5-pin connector			
Power Consumption				
Intel® i3-N305 (15W)		DC-in Voltage		
Status	C-States	12v	24v	35v
Standby				
Power Saving	Enabled	1.76W	2.23W	2.48W
	Disabled			
Idle	Enabled	10.53W	10.58W	10.6W
	Disabled			
Burnin PL1	Disabled	20.7W	21.3W	22.8W
	Enabled			
Burnin PL2	Disabled	36.6W	37.42W	38.78W
	Enabled			
Mechanical				

Dimension	161.5 mm (W) x 169 mm (D) x 52.7 mm (H)
Weight	1.8kg
Mounting	Wall-mount or DIN-rail mount (Optional)
Environmental	
Operating Temperature	-25°C to 70°C
Storage Temperature	-40°C to 85°C
Humidity	10% to 90% , non-condensing
Vibration	MIL-STD-810H, Method 514.8, Category 4
Shock	MIL-STD-810H, Method 516.8, Procedure I
EMC	CE/FCC Class A, according to EN 55032 & EN 55035
Safety	UL 62368-1, IEC 62368-1
Ingress Protection	IP67 compliant when POC-766AWP panel installed.

1.3 Dimension

 **NOTE**

All measurements are in millimeters (mm).

The POC-766AWP series systems share the same dimensions, additional illustrations will be shown to demonstrate differences.

1.3.1 Superior View

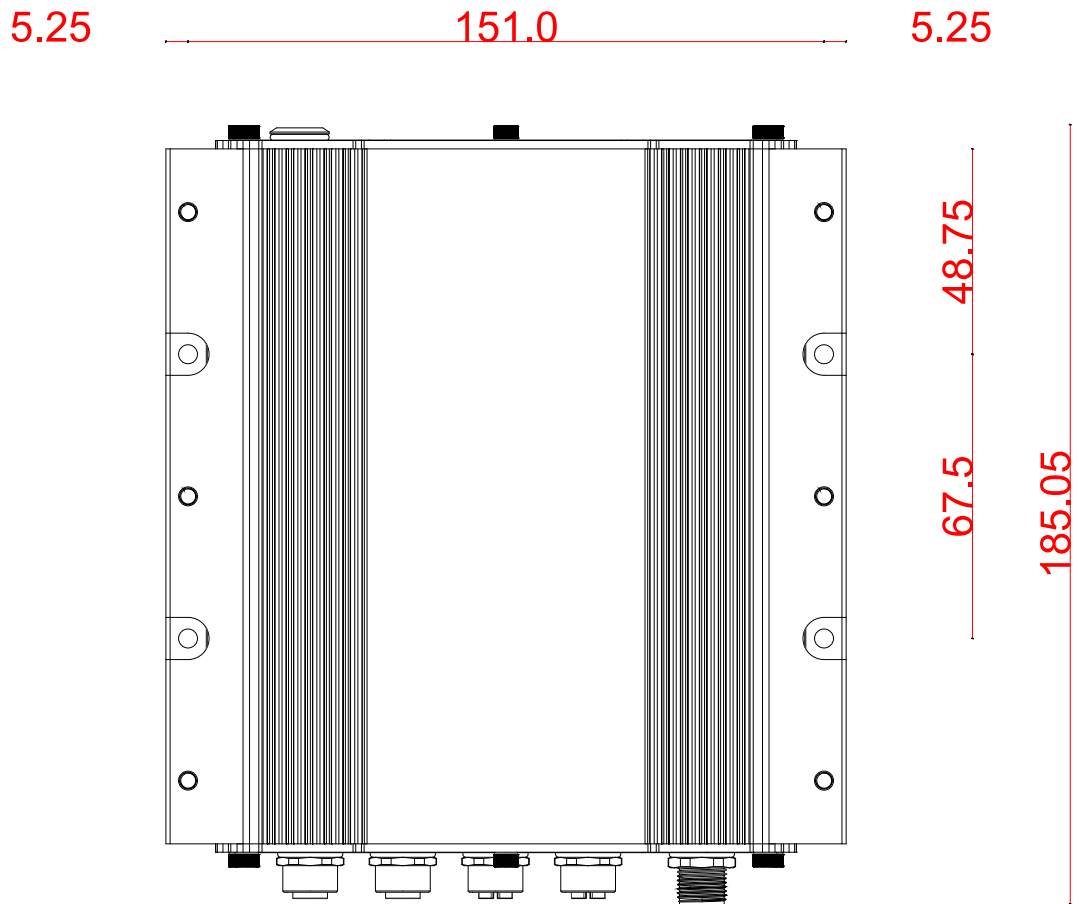

1.3.2 M12 IO Panel View

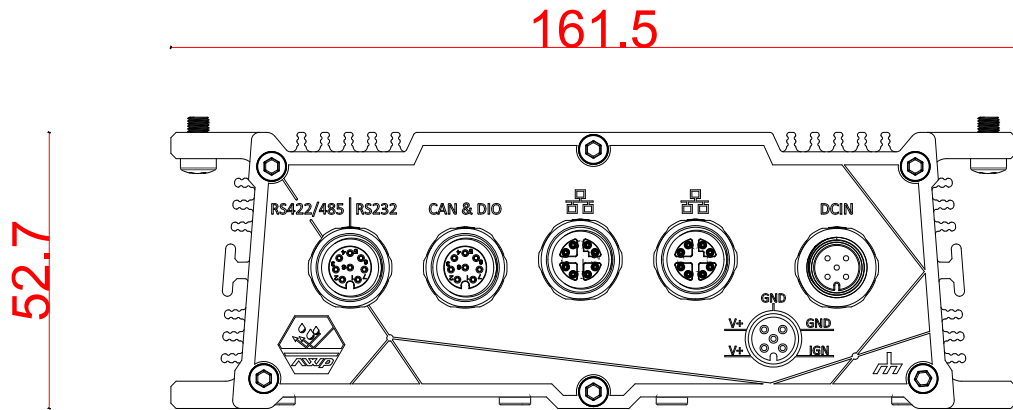

1.3.3 IO Panel View

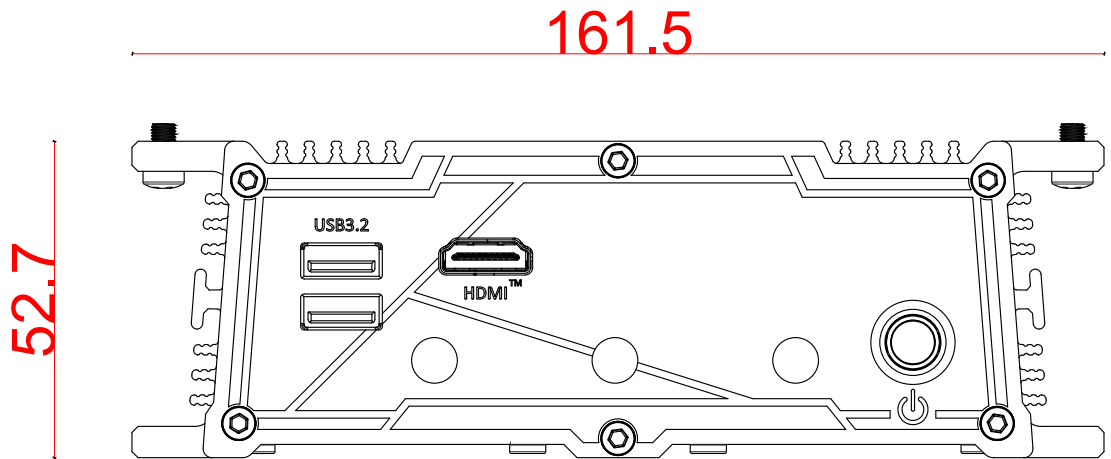

POC-766AWP-DEV IO panel

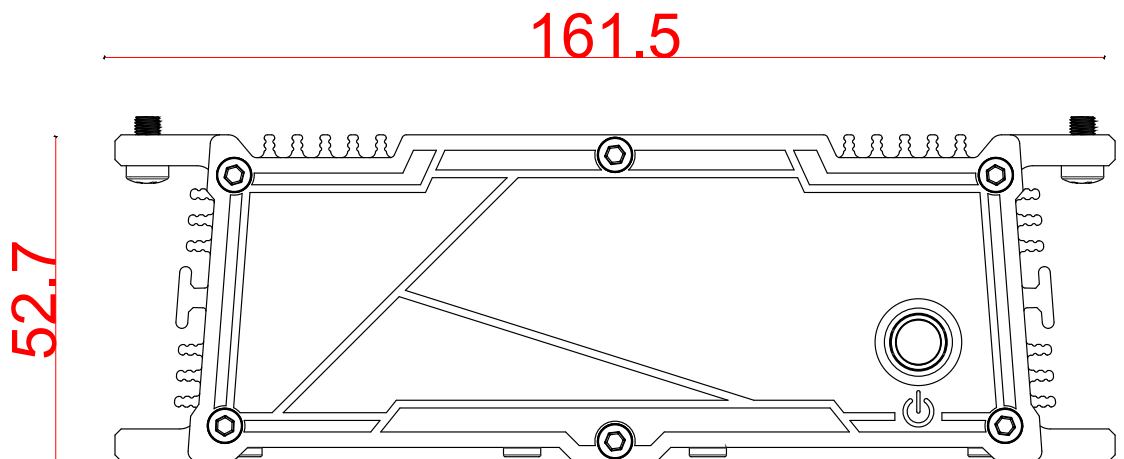

POC-766AWP With waterproof panel

1.4 POC-766AWP Mounting Options

The system comes with various mounting options such as DIN-rail and wall-mount bracket. DIN-rail mount clip is shipped with POC-600 series as standard mounting option, and an optional wall mount (purchased separately).

1.4.1 Wall Mount

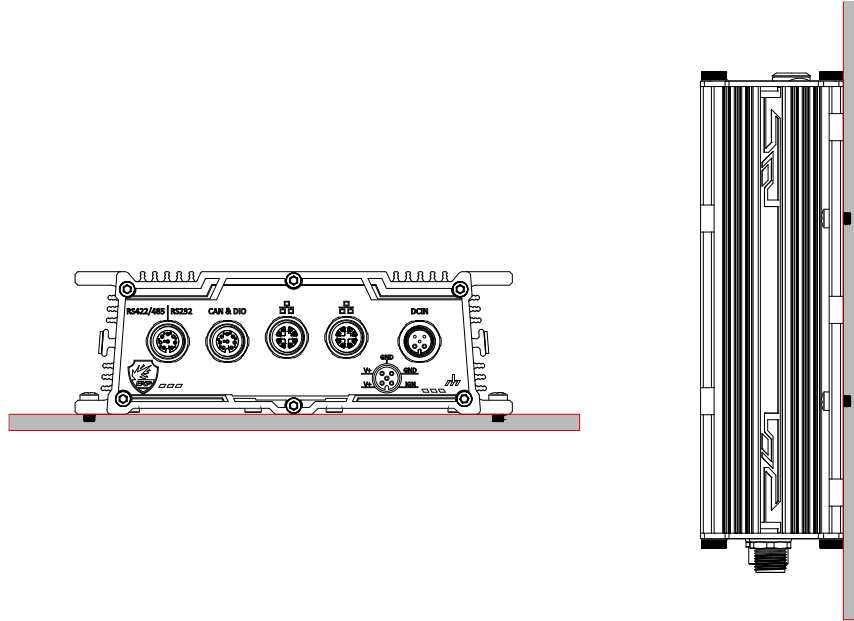

1.4.2 Flattop Design Mount

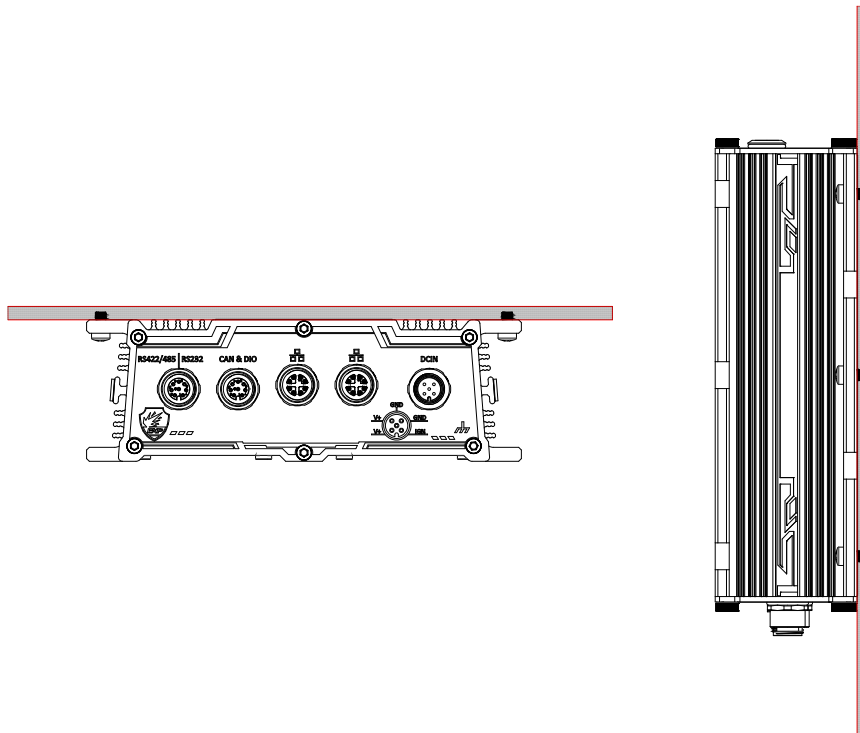

1.4.3 DIN-Rail Mount Clip (Optional)

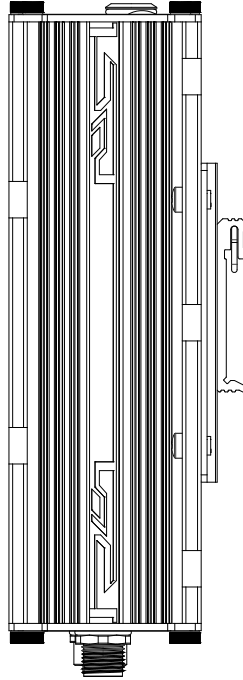

2 System Overview

Upon receiving and unpacking your POC-766AWP series, please check immediately if the package contains all the items listed in the following table. If any item(s) are missing or damaged, please contact your local dealer or Neousys Technology.

2.1 Unpacking the System

2.1.1 POC-766AWP

Item	Description	Qty
1	POC-766AWP-DEV ultra-compact fanless computer (Please verify additionally purchased accessories such as memory module, M.2 SSD, etc.)	1
2	O-ring	1
3	Screw package	1
4	High temperature warning label*	1

2.1.2 POC-766AWP-DEV

Item	Description	Qty
1	POC-766AWP ultra-compact fanless computer (Please verify additionally purchased accessories such as memory module, M.2 SSD, etc.)	1
2	Rear panel (with power button)	1
3	O-ring	1
4	Screw package	1
5	High temperature warning label*	1

* A high-temperature warning sticker is provided for users to place on surfaces that may become hot during operation.

2.2 POC-766AWP Series Front Panel

The front panel of POC-766AWP series features isolated COM, CAN, DIO, two 2.5Gb Ethernet, and DC input, all via M12 connectivity.

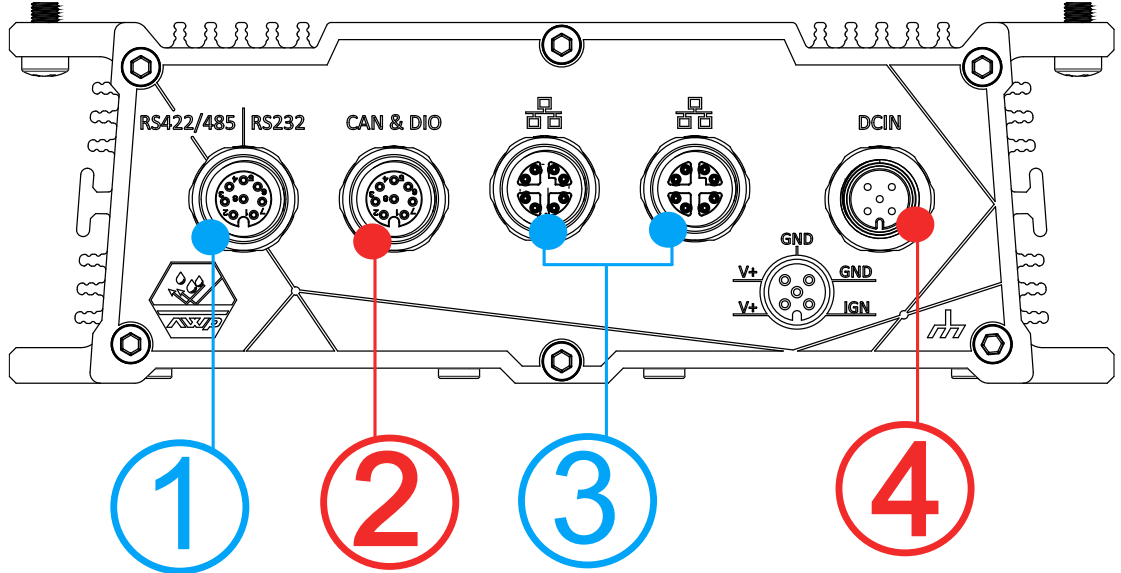

No.	Item	Description
1	M12 A-coded Isolated COM	COM 1 is isolated RS-232 port with 15 kV ESD protection COM 2 is RS422/485 port with 15 kV ESD protection
2	M12 A-coded CAN bus & DIO	1x isolated CAN2.0B 1-CH isolated DI and 2-CH isolated DO
3	M12 X-coded 2.5Gb Ethernet	The Ethernet port offers up to 2.5Gb/s transfer bandwidth
4	M12 A-coded DC-in	8V to 35V DC input

2.2.1 M12 A-coded Isolated COM Port

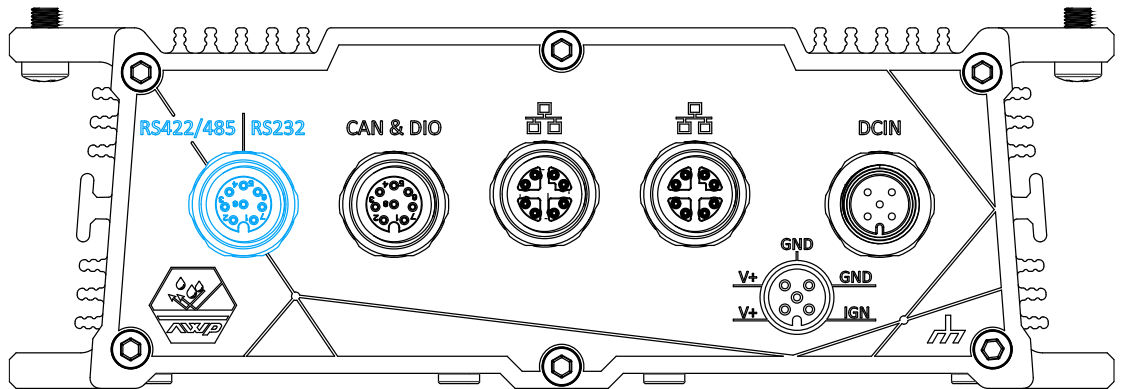

The system provides two isolated COM ports via an M12 A-coded connector for communicating with external devices. COM 1 port is a 3-wire RS-232 specifications and provide up to 115200 bps baud rate while COM2 port is RS-422/485 specifications.

Connector Pin Definition

RS422/485 RS232

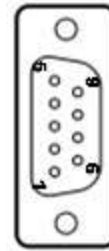
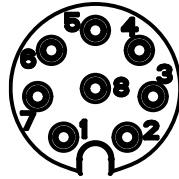
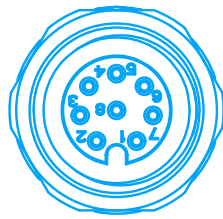

M12 Panel side		M12 Cable end	COM cable	Signal
Signal	M12 panel pin	M12 cable pin	COM pin	
RXD1	1	1	2	COM1
TXD1	6	6	3	
GND	7	7	5	
TXPS	2	2	2	COM2
TXN2	3	3	8	
RXP2	4	4	3	
RXN2	5	5	4	
GND	8	8	5	

2.2.2 M12 A-coded CAN bus & DIO

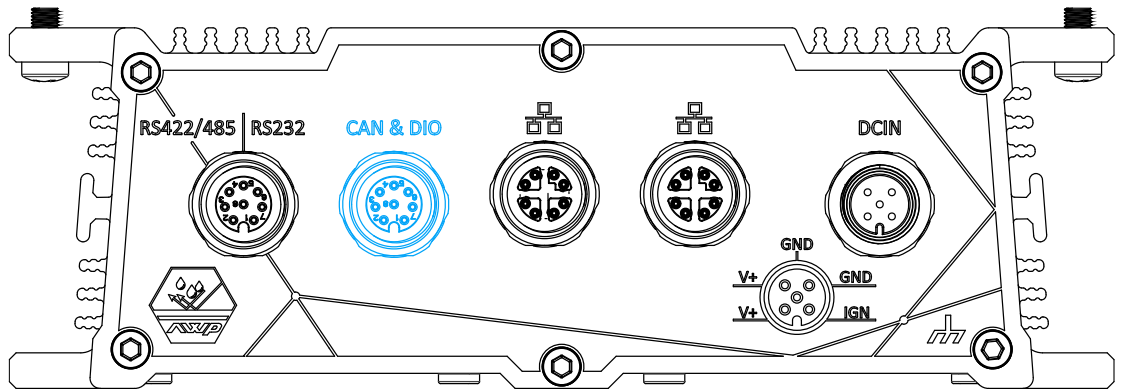

The system provides 1x isolated digital input channels, 2x isolated digital output channels, and one CAN bus port via an M12 A-coded connector. The DIO functions support polling mode I/O access and DI change-of-state interrupt. Please refer to [Watchdog Timer & Isolated DIO](#) for information on wiring and programming the isolated DIO channels.

Digital I/O Pin Definition

CAN & DIO

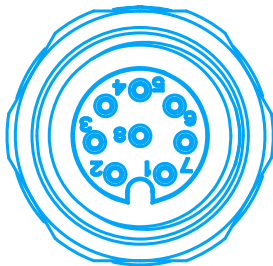

Pin No.	Pin Definition	Signal
1	CANBUS_CN1_H	CAN Bus
2	CANBUS_CN1_L	
3	CANBUS_ISOGND	
4	ISO_CNB_DI0	DI 0
5	ISO_CNA_DI0	
6	ISO_CN_DOCOM	DO 0 & 1
7	ISO_CN_DO1	
8	ISO_CN_DO0	

2.2.3 M12 X-coded 2.5Gb Ethernet Port

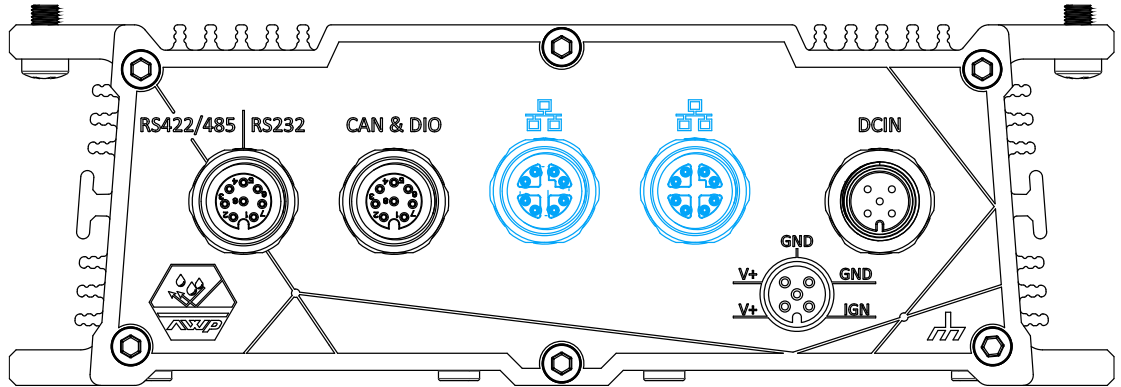

The system offers 2.5Gb Ethernet ports using Intel® I226-IT controller via an M12 X-coded, 8-pin connector.

Connector Pin Definition

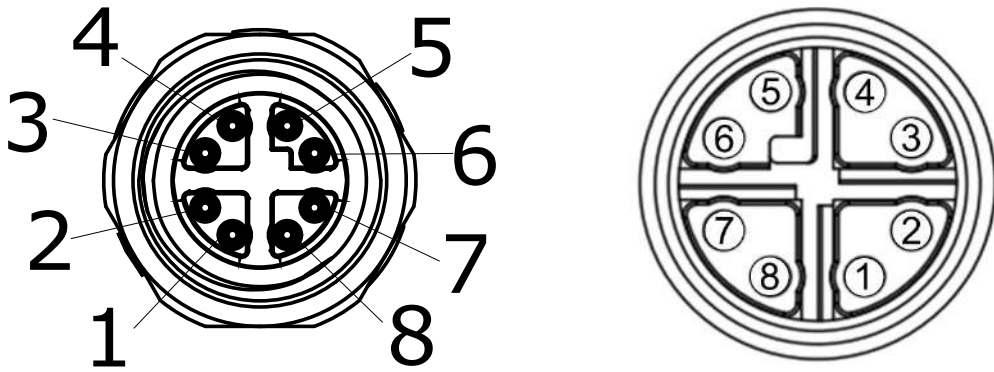

Panel side

Cable connector end

Signal	M12 panel side	M12 cable connector end	Wire color
LAN P0	1	1	Yellow
LAN N0	2	2	Yellow
LAN P1	3	3	Green
LAN N1	4	4	Green
LAN P3	5	5	Orange
LAN N3	6	6	Orange
LAN N2	7	7	Blue
LAN P2	8	8	Blue

2.2.4 M12 A-coded DC-in Port

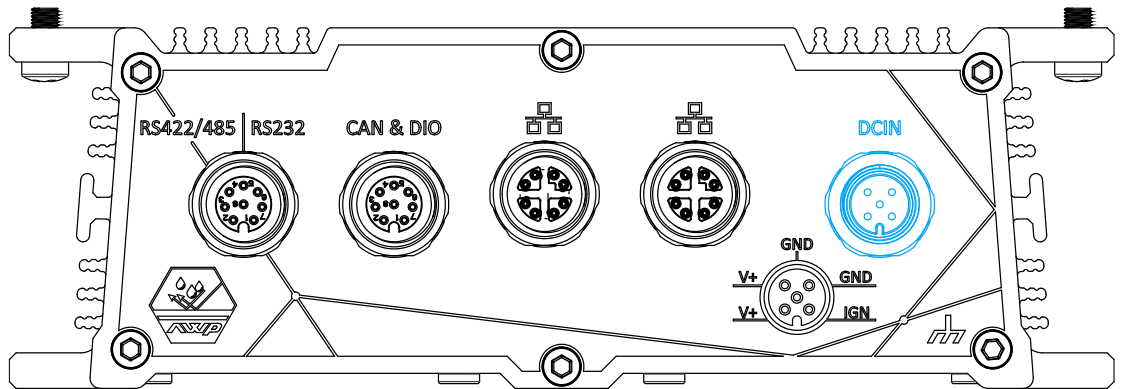

The system accepts a wide range of DC power input from 8V to 35V via a M12 A-coded connector. The M12 A-coded connectors offer COTS availability and ultra-rugged connection reliability when wiring DC power.



NOTE

Please make sure the voltage of DC power is correct before you connect it to the system. Supplying a voltage over 35V will damage the system.

Connector Pin Definition

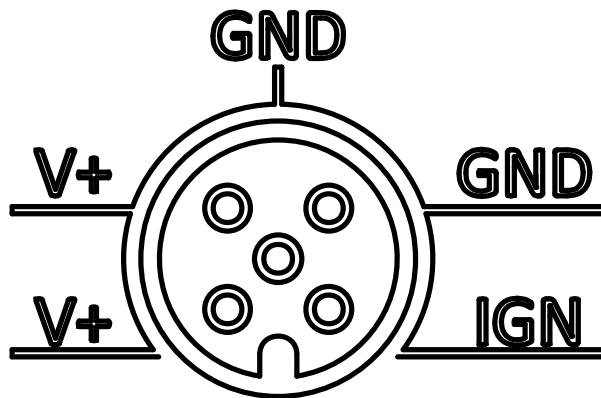

Euro PIN (cable side)	Wire color
IGN	Yellow
V+	Red
GND	Black

2.3 POC-766AWP Power Button & Clear CMOS

The POC-766AWP rear panel features a power button.

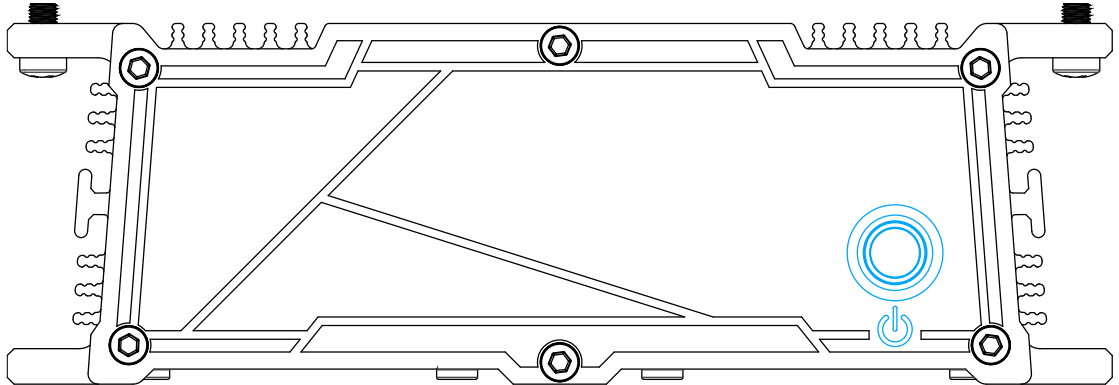

The power button is a non-latched switch for ATX mode on/off operation. Press to turn on the system, PWR LED should light up and to turn off, you can either issue a shutdown command in the OS, or just press the power button. In case of system halts, you can press and hold the power button for 5 seconds to force-shutdown the system. Please note that there is a 5 seconds interval between two on/off operations (i.e. once turning off the system, you will need to wait for 5 seconds to initiate another power-on operation).

To clear the system CMOS using the power button, please refer to the following instructions.

1. Unplug the DC power cable from the system.
2. With the cable unplugged, press and hold the power button.
3. With the power button held down, reconnect the DC power cable to the system.
4. Continue to press and hold down the button for a further 5 seconds after connecting the DC power cable.
5. Release the power button to complete the clear CMOS procedure.

2.4 POC-766AWP-DEV I/O Panel

The POC-766AWP-DEV I/O panel has two USB3.2 ports, an HDMI™ port, three antenna openings, and a power button.

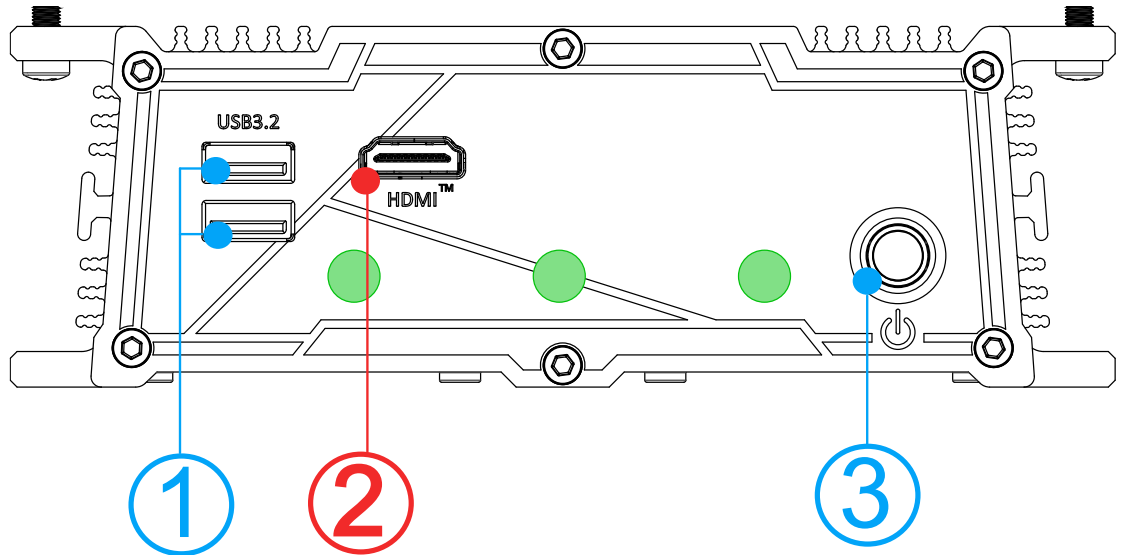

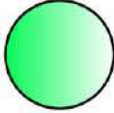
No.	Item	Description
1	USB 3.2 Gen 1 port	The USB 3.2 Gen1 ports support up to 5Gbit/s data transfer bandwidth and are backward compatible with USB 2.0/ 1.1/ 1.0.
2	HDMI™ Port	The HDMI™ port can support up to 3840 x 2160 @ 60Hz resolution.
3	Power button	Use this button to turn on or shutdown the system.
		Opening reserved for SMA antenna installation

2.4.1 USB 3.2 Gen 1 Port (POC-766AWP-DEV)

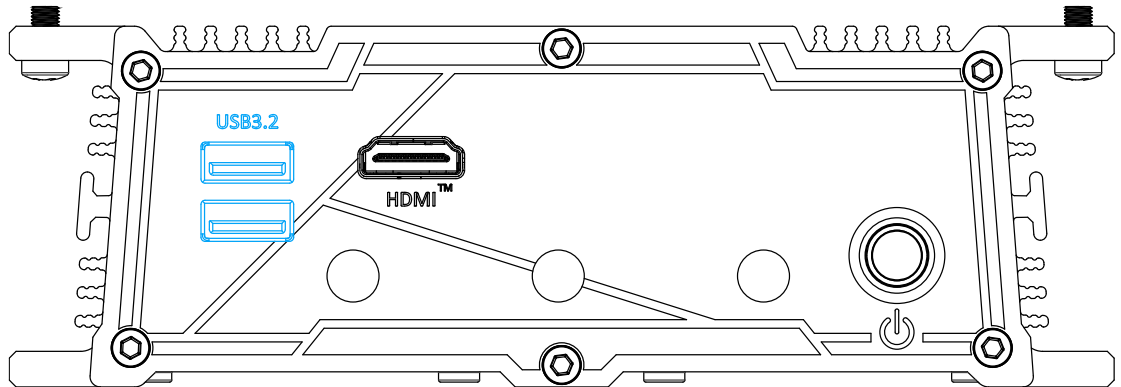

The system offers two USB 3.2 Gen1 (SuperSpeed USB) ports on its front panel. They are implemented by native xHCI (eXtensible Host Controller Interface) controller and are backward compatible with USB 2.0, USB 1.1 and USB 1.0 devices. UEFI USB support is also provided so you can use USB keyboard/mouse in UEFI shell environment

xHCI driver is supported natively in Windows 10, therefore you do not need to install xHCI driver in prior to utilize USB function on the system.

2.4.2 HDMI™ Port (POC-766AWP-DEV)

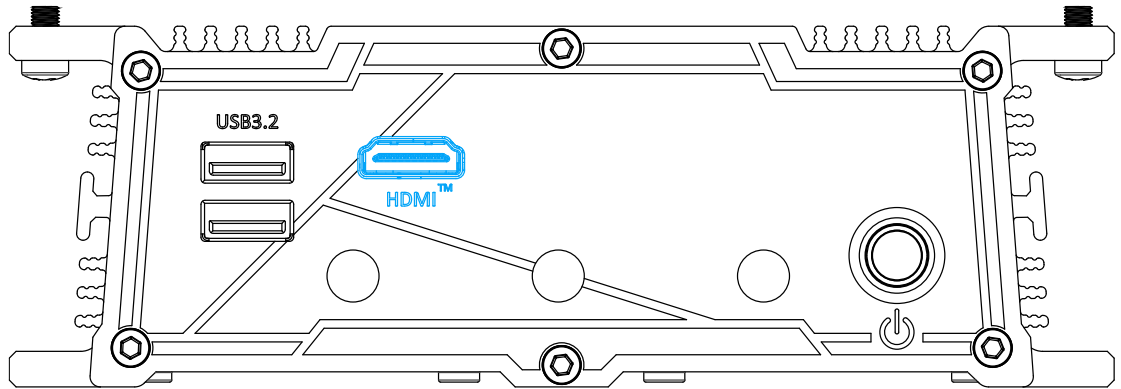

The High-Definition Multimedia Interface (HDMI) port provides uncompressed high-quality digital video and audio transmission between the system and a multimedia display device on a single cable. You can connect to other digital inputs by using a HDMI-to-DVI or HDMI-to-DP cable.



HDMI-to-DP

To achieve the best DisplayPort output resolution in Windows, you need to install corresponding graphics drivers. Please refer to section [OS Support and Driver Installation](#) for details.

2.4.3 Power Button & Clear CMOS (POC-766AWP-DEV)

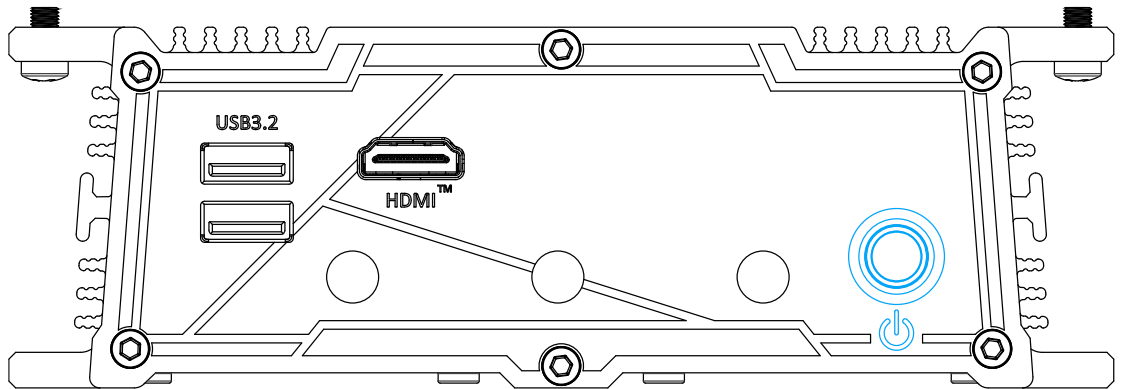

The power button is a non-latched switch for ATX mode on/off operation. Press to turn on the system, PWR LED should light up and to turn off, you can either issue a shutdown command in the OS, or just press the power button. In case of system halts, you can press and hold the power button for 5 seconds to force-shutdown the system. Please note that there is a 5 seconds interval between two on/off operations (i.e. once turning off the system, you will need to wait for 5 seconds to initiate another power-on operation).

To clear the system CMOS using the power button, please refer to the following instructions.

1. Unplug the DC power cable from the system.
2. With the cable unplugged, press and hold the power button.
3. With the power button held down, reconnect the DC power cable to the system.
4. Continue to press and hold down the button for a further 5 seconds after connecting the DC power cable.

Release the power button to complete the clear CMOS procedure.

2.4.4 SMA Antenna Opening (POC-766AWP-DEV)

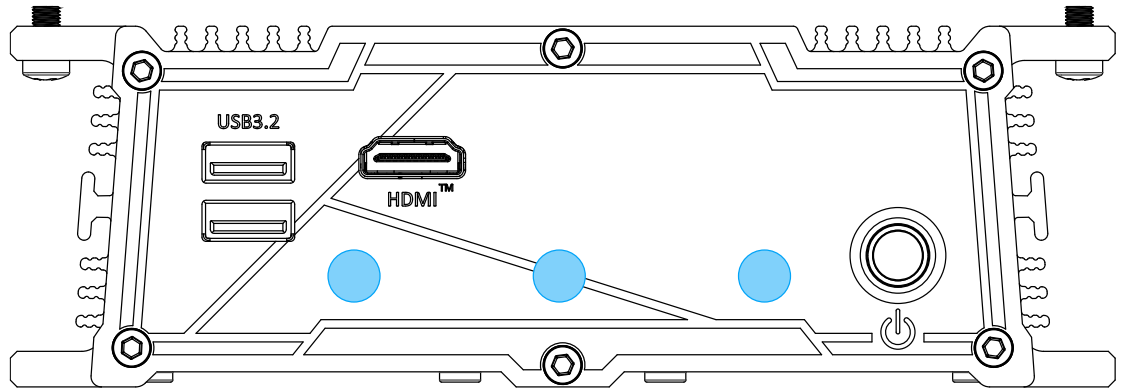

The system offers four SMA antenna openings reserved for SMA antenna installations. Users can take advantage of these four openings when installing wireless communication modules such as 5G/ LTE, WiFi 6, WiFi 5, etc.

2.5 POC766AWP Series Internal I/O

The system's internal I/O connectors consist of a SO-DIMM socket, M.2 2280 M key NVMe, mini-PCIe port for application-oriented expansion purposes.

2.5.1 SO-DIMM Memory Socket



The system has an internal SO-DIMM slot supporting a single DDR5-4800 memory module up to 16GB in capacity.

2.5.2 M.2 2280 M Key



The system has an M.2 2280 slot (PCIe Gen3 x4 and SATA signal) for you to install an SSD for faster access over traditional hard disk drives.

M.2 2280 M Key Pin Definition

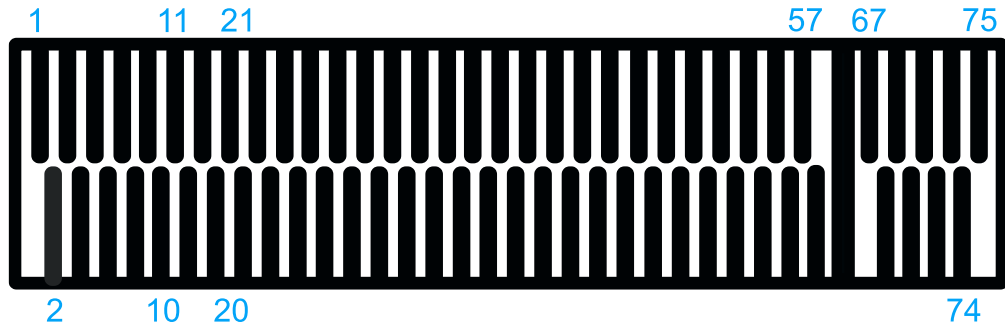

Pin #	Signal	Pin #	Signal
1	GND	2	+3V3
3	GND	4	+3V3
5	PERN3	6	-
7	PERP3	8	-
9	GND	10	DAS/DSS N
11	PETN3	12	+3V3
13	PETP3	14	+3V3
15	GND	16	+3V3
17	PERN2	18	+3V3
19	PERP2	20	-
21	GND	22	-
23	PETN2	24	-
25	PETP2	26	-
27	GND	28	-
29	PERN1	30	-
31	PERP1	32	-
33	GND	34	-
35	PETN1	36	-
37	PETP1	38	-
39	GND	40	-
41	PERn0 / SATA-B+	42	-
43	PERp0 / SATA-B-	44	-
45	GND	46	-
47	PETn0 / SATA-A-	48	-
49	PETp0 / SATA-A+	50	PERST N
51	GND	52	-
53	REFCLKN	54	-
55	REFCLKP	56	-
57	GND	58	-
Mechanical Key			
67	-	68	SUSCLK
69	PEDET	70	+3V3
71	GND	72	+3V3
73	GND	74	+3V3
75	GND		

2.5.3 mini-PCIe Slot



The system provides a mini-PCIe socket (indicated in **blue**) that is in compliance with mini-PCIe specification rev. 1.2. This mini-PCIe socket is designed with SIM card (slot indicated in **red**) support. With a SIM card installed, your system can access the internet via your network provider’s 5G/ 4G network.

For wireless (WiFi/ 5G/ 4G) communication, multiple SMA antenna apertures can be located on the panel.

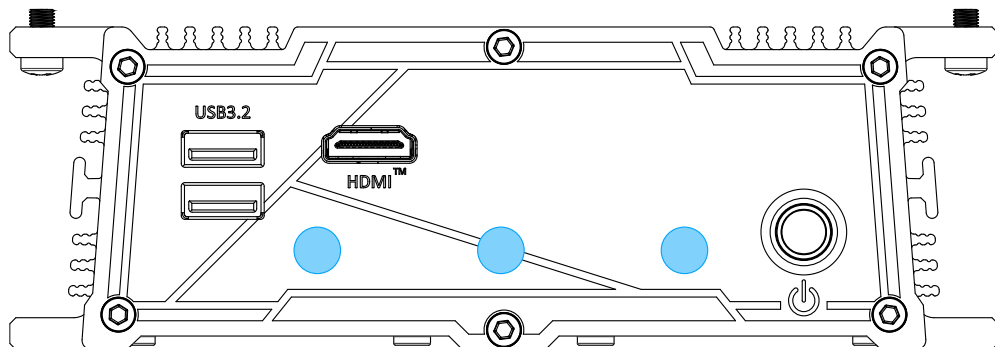

Antenna opening on POC-766AWP-DEV

mini-PCle socket definition

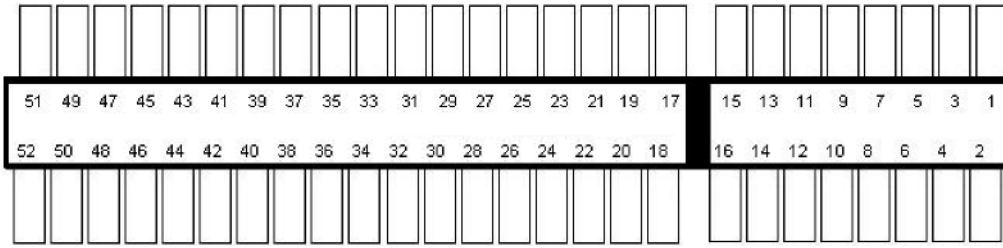

Pin	Signal (mPCle)	Pin #	Signal (mPCle)
1	WAKE#	2	+3.3Vaux
3	-	4	GND
5	-	6	+1.5V
7	CLKREQ#	8	UIM PWR
9	GND	10	UIM DATA
11	REFCLK-	12	UIM CLK
13	REFCLK+	14	UIM RESET
15	GND	16	UIM VPP
Mechanical Key			
17	Reserved* (UIM C8)	18	GND
19	Reserved* (UIM C4)	20	W DISABLE#
21	GND	22	PERST#
23	PERn0	24	3.3V
25	PERp0	26	GND
27	GND	28	+1.5V
29	GND	30	SMB_CLK
31	PETn0	32	SMB_DATA
33	PETp0	34	GND
35	GND	36	USB D-
37	GND	38	USB D+
39	3.3V	40	GND
41	3.3V	42	-
43	GND	44	-
45	Reserved	46	-
47	Reserved	48	+1.5V
49	Reserved	50	GND
51	Reserved	52	3.3V

 **NOTE**

Some off-the-shelf mini-PCle 5G/4G modules are not compliant to standard mini-PCle interface. They use 1.8V I/O signals instead of standard 3.3V I/O and may cause signal conflict. Please consult with Neousys for compatibility when in doubt! Installing an incompatible 4G module may damage the system or the module itself may be damaged.

3 System Installation

Before disassembling the system enclosure and installing components and modules, please make sure you have done the following:

- It is recommended that only qualified service personnel should install and service this product to avoid injury or damage to the system.
- Please observe all ESD procedures at all times to avoid damaging the equipment.
- Before disassembling your system, please make sure the system has powered off, all cables and antenna (power, video, data, etc.) are disconnected.
- Place the system on a flat and sturdy surface (remove from mounts or out of server cabinets) before proceeding with the installation/ replacement procedure.

3.1 Disassembling the System Enclosure

To install necessary components such as memory module, M.2 modules or mini-PCIe module, you need to remove the system's bottom panel. To do so, Please refer to the following instructions

1. To remove the bottom panel of the system, place the system on a sturdy surface, and turn the system upside-down. Remove the screws on the bottom panel indicated.

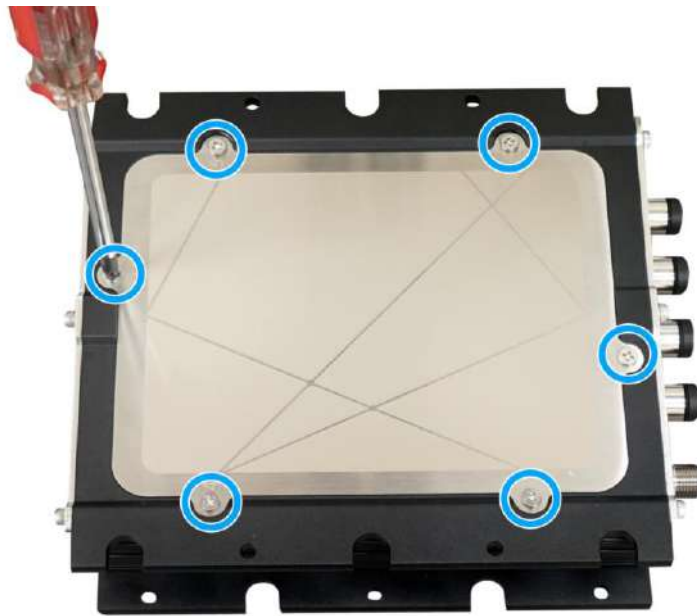

2. Separate the bottom panel from the system to access internal expansion slots (DRAM, M.2 are located under the heatsink).



3.2 Installing Internal Components

3.2.1 SO-DIMM Installation

There is one SO-DIMM memory slot on the motherboard. Please follow the procedures below to install the memory module.

1. [Disassemble the system enclosure](#)
2. Remove the screws indicated.

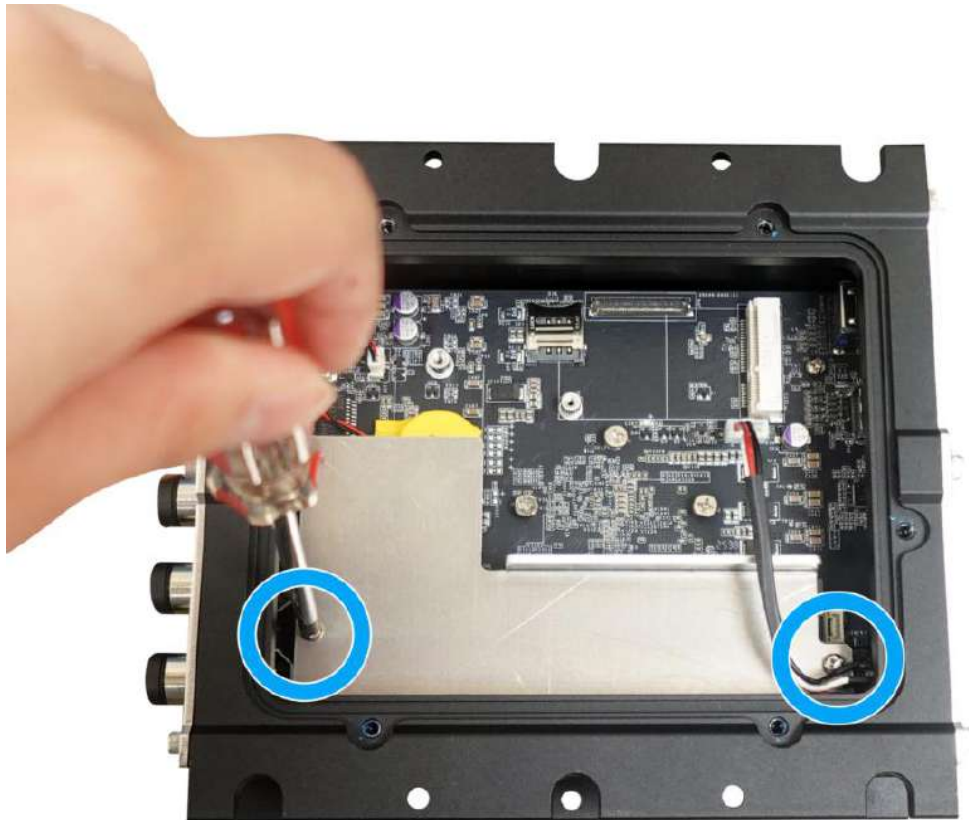

3. **To install**, insert the gold finger end of the SO-DIMM on a 45 degree angle.



NOTE

For demonstration purposes, we have removed all internal heatsinks.



4. Gently push the SO-DIMM down until it clips-in.



5. Remove the **memory thermal pad protection film**, and the **side thermal pad protection film** for the heatsink.

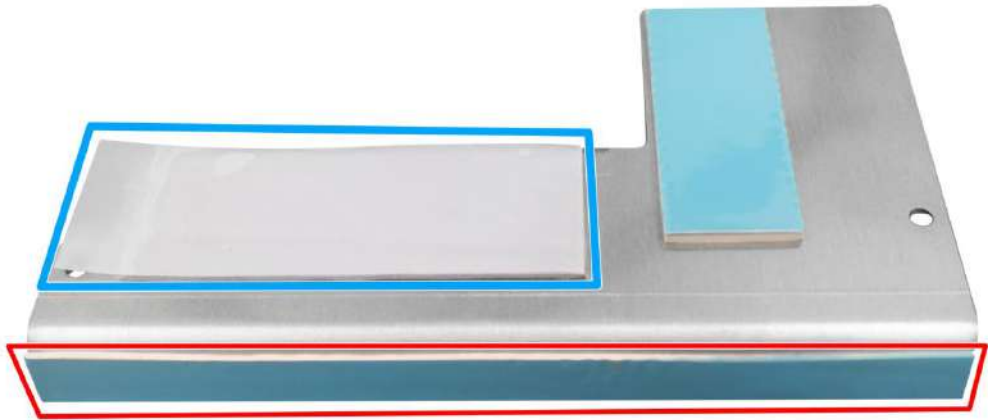

6. Reinstall the DRAM/ M.2 heatsink, and secure the heatsink with the screws indicated.

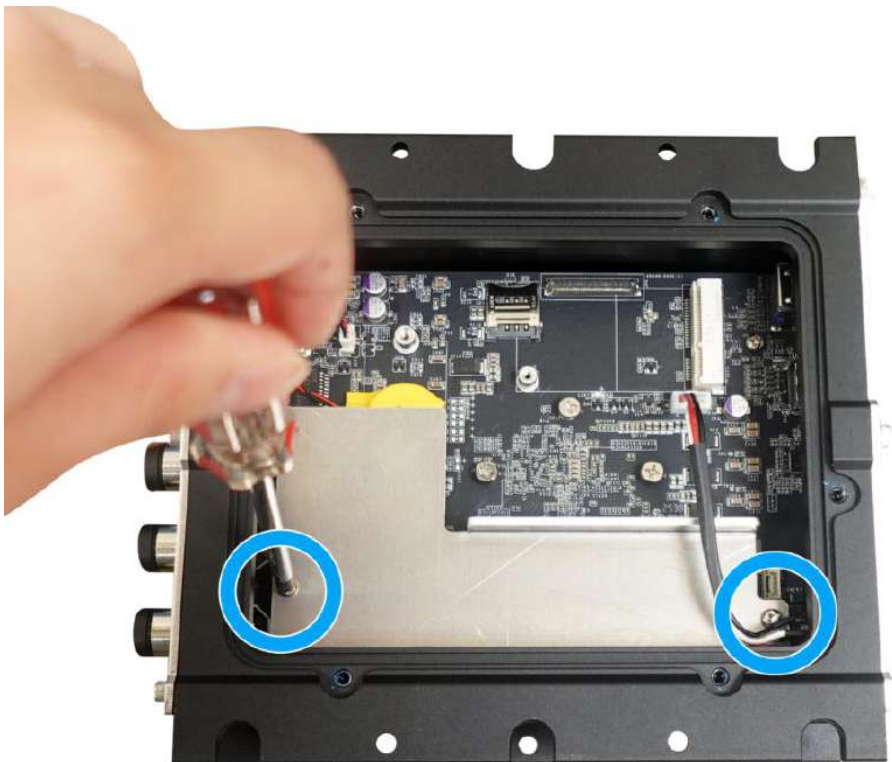

7. [Reinstall the system enclosure.](#)

3.2.2 M.2 2280 M Key Module Installation

There is an M.2 2280 M key module expansion slot on the motherboard. Please follow the procedures below for installation.

1. [Disassemble the system enclosure.](#)
2. Remove the screws indicated.

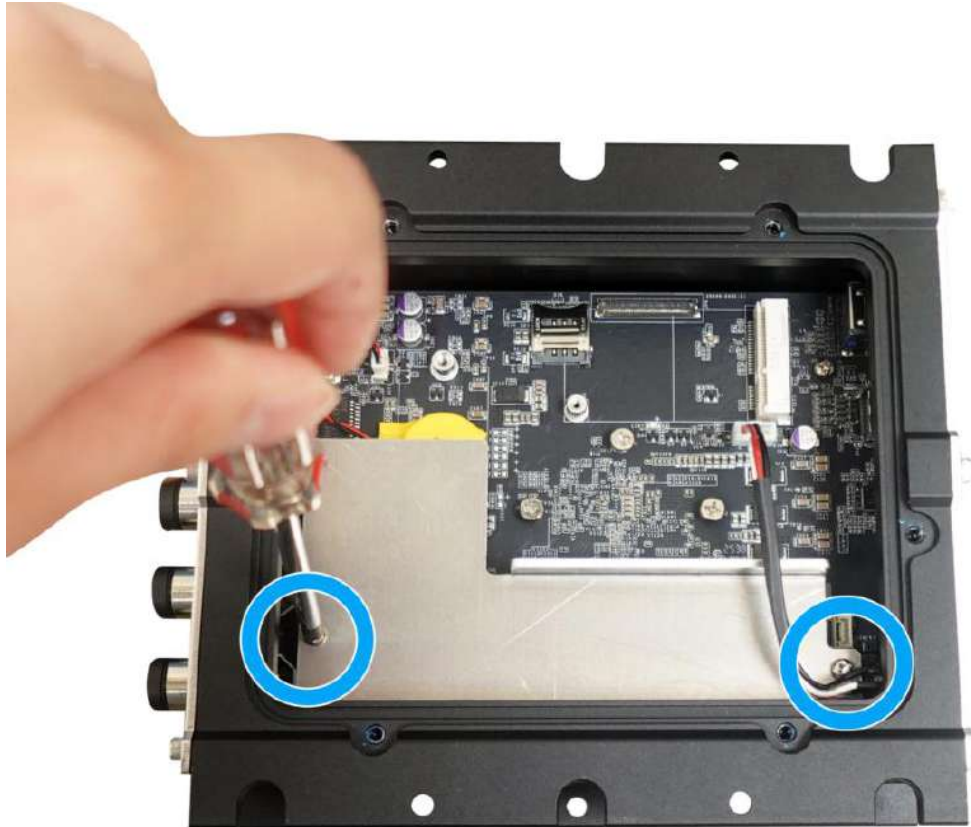

3. Insert the M.2 2280 module on a 45 degree angle.



4. Gently press the card down and secure with a screw.



5. Remove the **thermal pad protection film for M.2 module**, and the **side thermal pad protection film** for the heatsink, if it has not already been removed

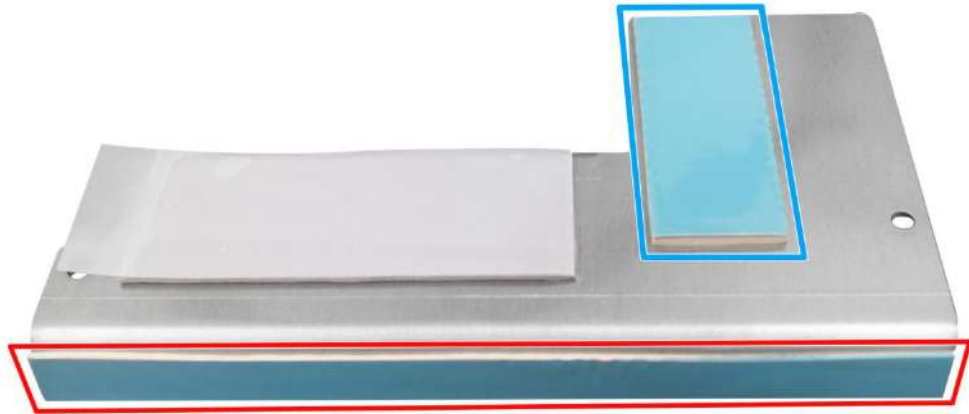

6. Reinstall the DRAM/ M.2 heatsink, and secure the heatsink with the screws indicated.

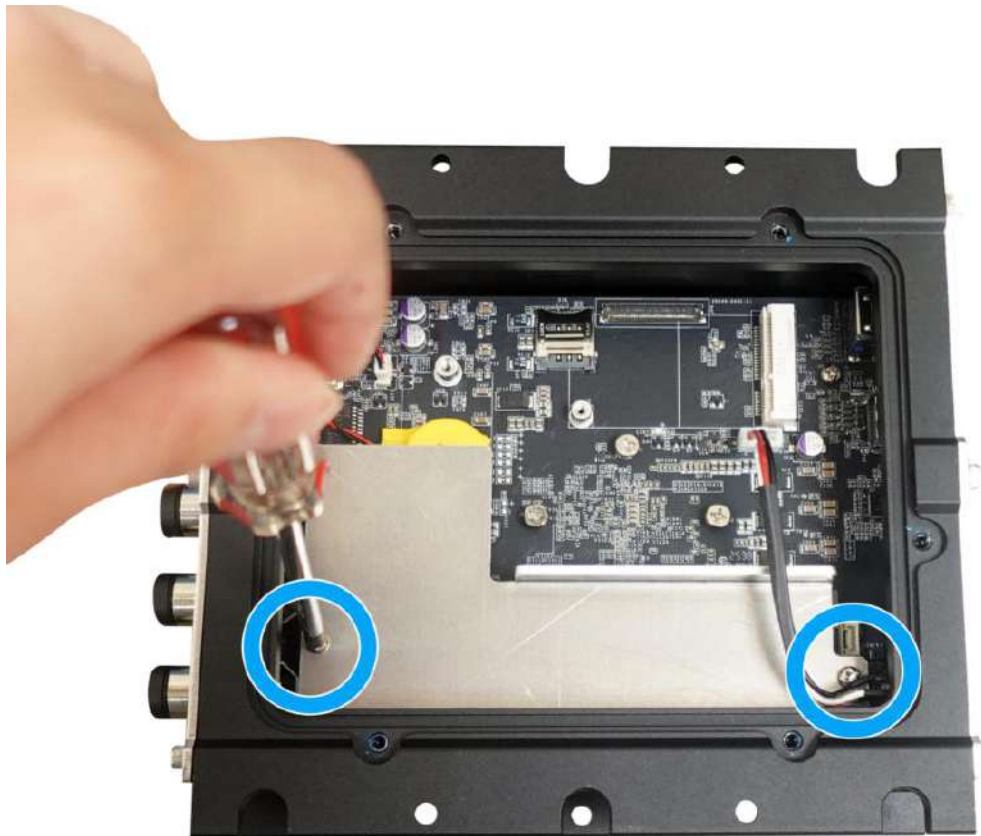

7. [Reinstall the system enclosure.](#)

3.2.3 mini-PCle Module Installation

The system comes with a **mini-PCle module expansion slot** and a **SIM slot**. For installation, please refer to the following procedure.



1. [Disassemble the system enclosure.](#)
2. If you are installing a 5G/ 4G wireless module that requires a SIM, please install the SIM card first. Otherwise go to the next step. Push the SIM slot holder in the direction shown and flip open the holder to place the SIM into the slot.

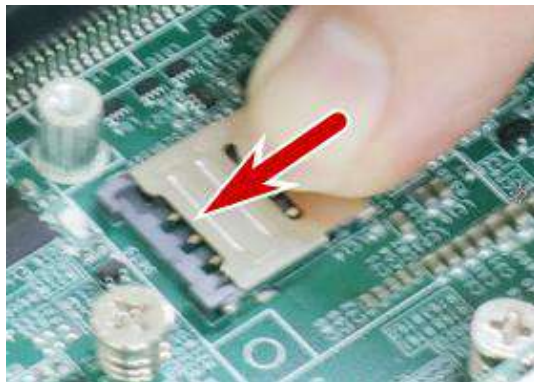

Push the SIM holder in the direction shown Flip open the holder and place SIM

3. Insert the mini-PCle module on a 45 degree angle.



NOTE

For demonstration purposes, we have removed all internal heatsinks.



4. Secure the mini-PCle module by securing the screw indicated.



- If you purchased the mini-PCIe module from Neusys, a heatsink and two copper stand-offs will be included. Remove the screws indicated and install the two copper stand-offs.



Remove the two screws indicated



Install the copper stand-offs

- Please remove the **thermal pad protection film for the mini-PCIe module**, and the **side thermal pad protection film** for the heatsink.

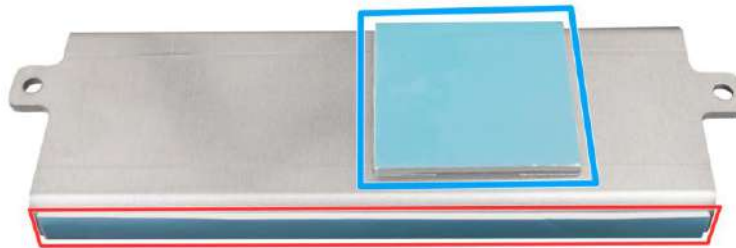

- Install the heatsink by securing the screws indicated.

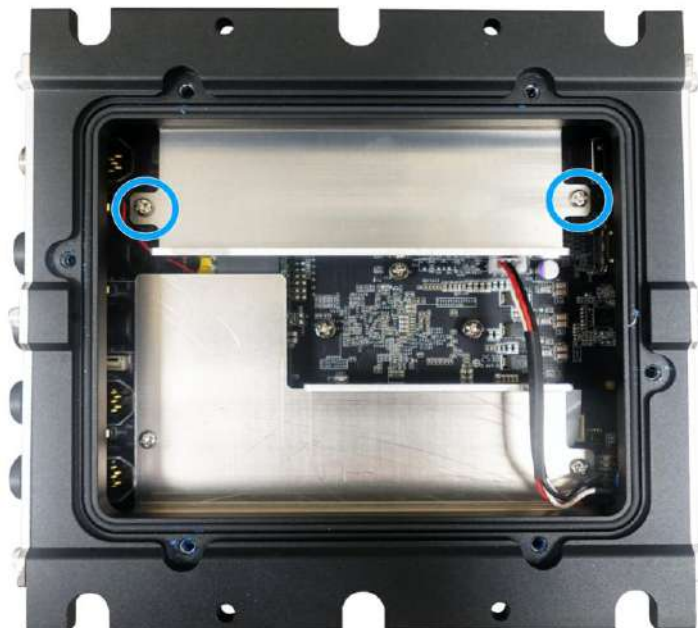

- [Reinstall the system enclosure.](#)

3.3 Installing the System Enclosure

1. To reinstall the system bottom panel, place the system on a sturdy surface, turn the system upside-down, and insert the O-ring into the groove. Make sure the O-ring is properly seated in place.



NOTE

Make sure the O-ring is properly seated in the groove! If not position in the groove, it may affect the waterproofing capability of the system.

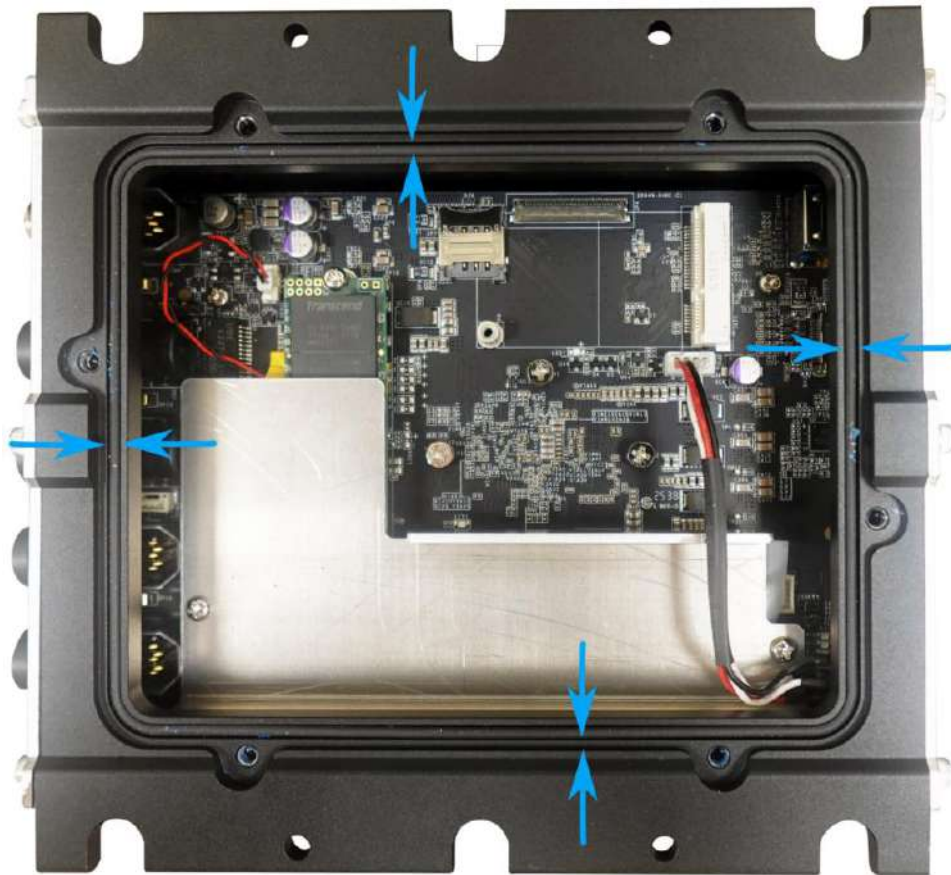

NOTE

There is a spare O-ring in the accessory box should you feel the need to swap out the existing O-ring due to wear and tear.

2. Place the bottom panel onto the system enclosure. Make sure the number 1 screw is facing the M12 connector side.

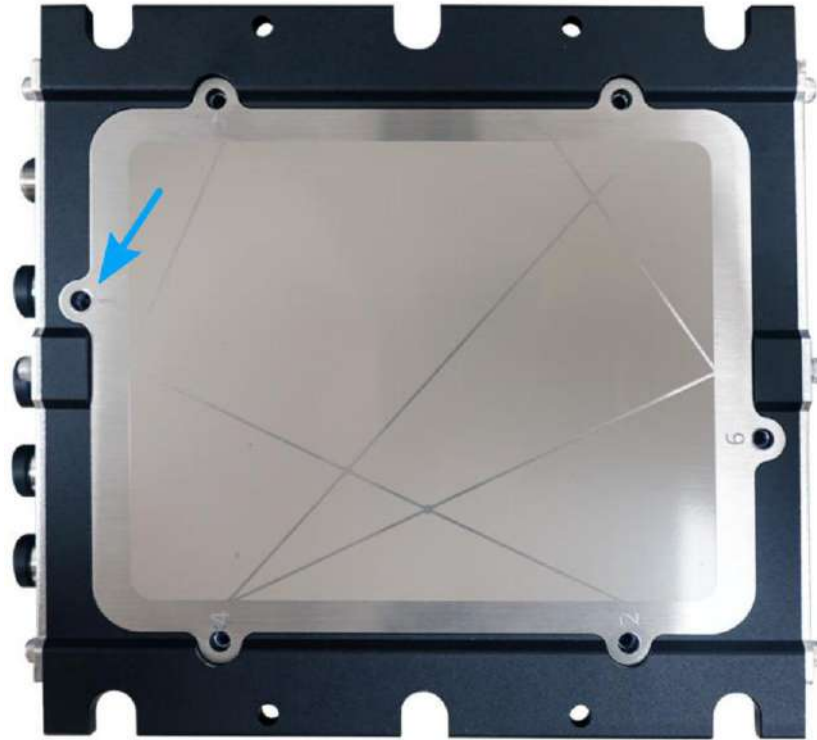

3. Secure the bottom panel in incremental order shown on the enclosure.

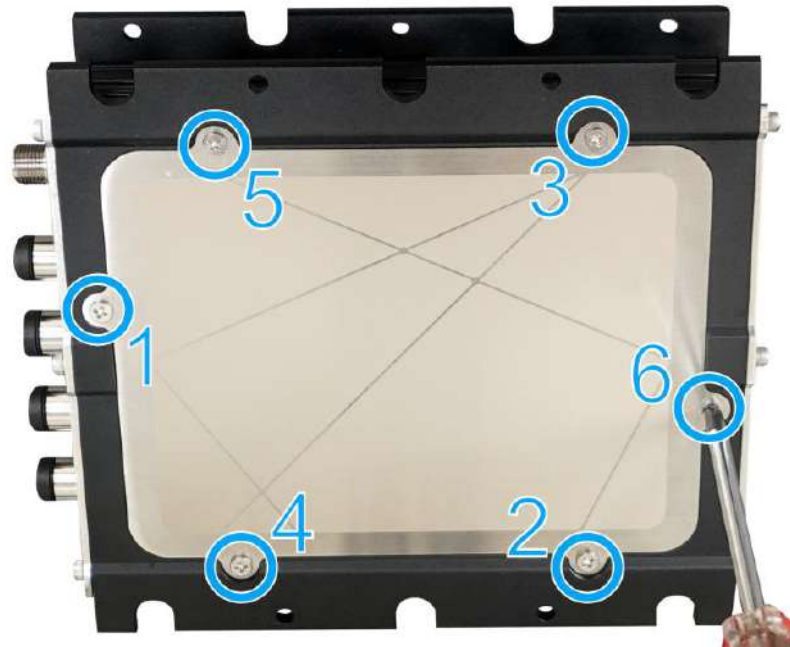
**NOTE**

Please secure each screw with 8.1 to 9.9Kgf-cm of torque force for waterproof capability.

3.4 Installing POC-766AWP Panel

If you purchased the POC-766AWP-DEV system and wish to switch to the POC-766AWP waterproof panel, please refer to the following procedure.

1. Remove the hexa-screw indicated on the POC-766AWP-DEV I/O panel.



2. [Disassemble the system enclosure.](#)
3. Disconnect the power cable connector.



- Remove the I/O panel.



- Insert the power button cable through the panel opening, and plug it onto the motherboard.



- Secure the hexa-screw tightness gradually in incremental order.



NOTE

Please secure each screw with 8.1 to 9.9Kgf-cm of torque force for waterproof capability.

7. Take the O-ring out of the accessory box, and place it into the groove.

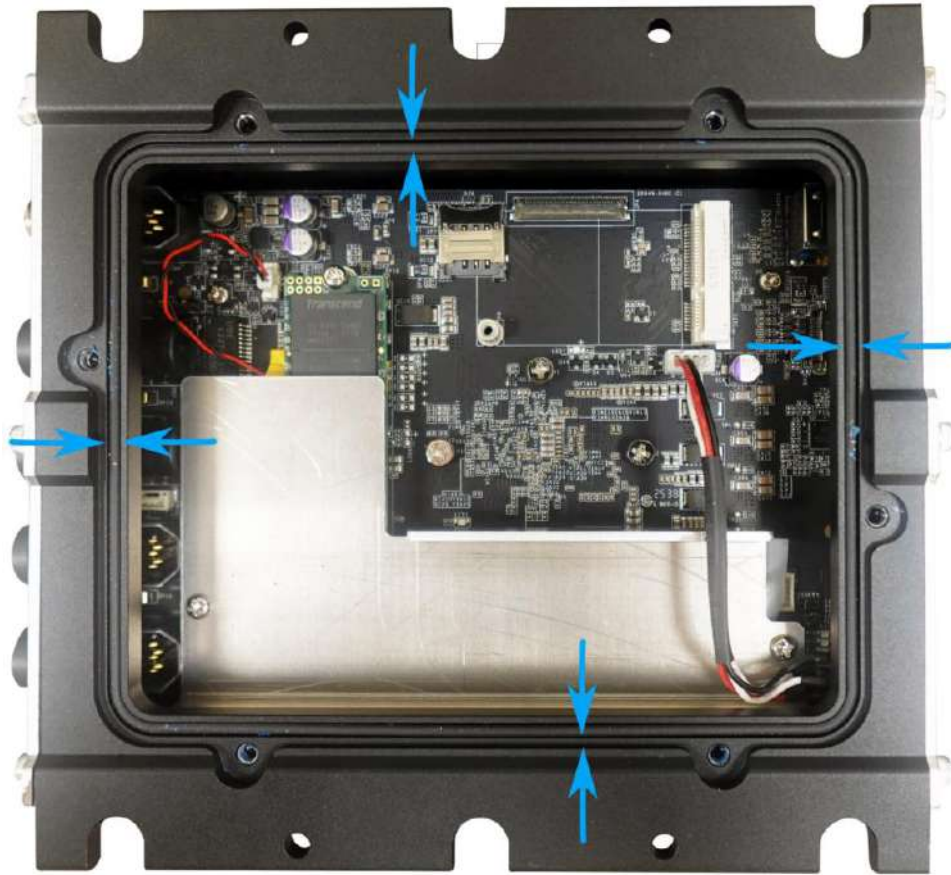

8. [Reinstall the system enclosure.](#)

3.5 Wall Mount Installation

3.5.1 Standard Wall Mount

To install the system as a wall mount device, please refer to the following instructions.

1. The wall mount brackets are built into the system enclosure. With the M12 connectors facing downward, simply find a flat sturdy surface and secure the system with four M4 screws.

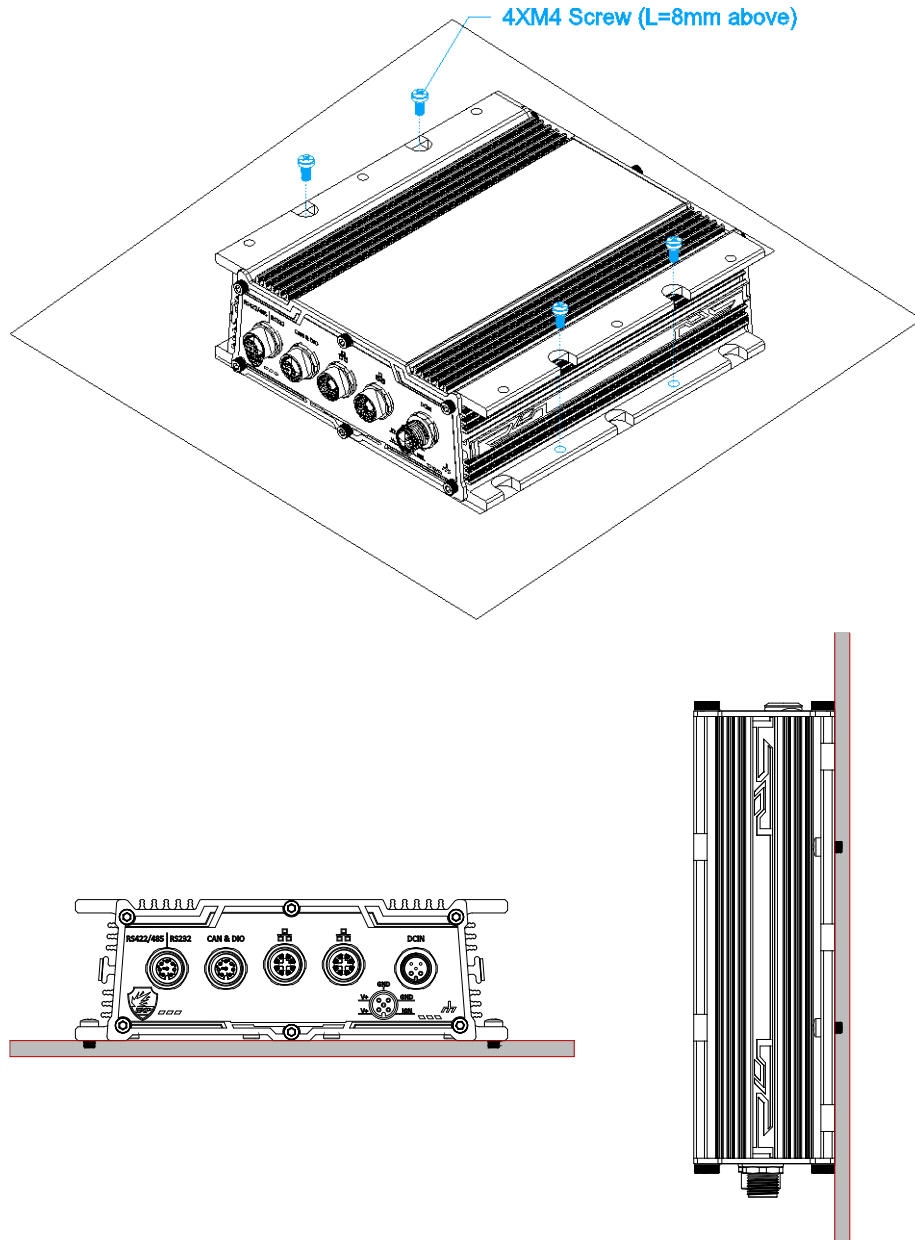

 **NOTE**
 Please note that the M12 connectors must be facing downwards when mounted.

3.5.2 Flattop Heatsink Mount

- To install, find a flat metallic surface, turn the system upside-down, With the M12 connectors facing downward, and secure with six **M4 screws**. Note that the flattop **thermal pad** should be between the system and the metallic surface.

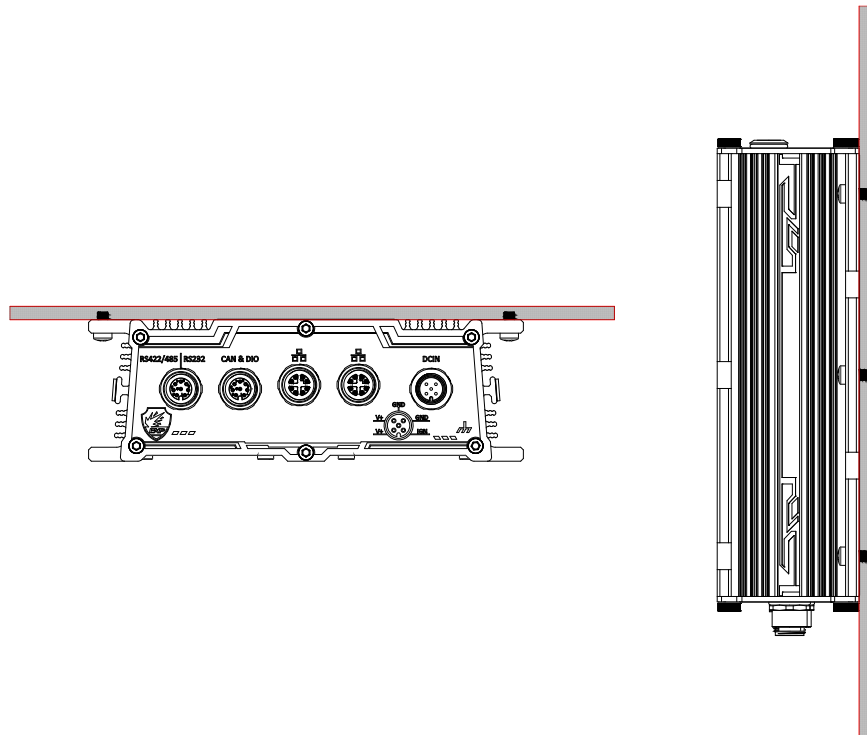
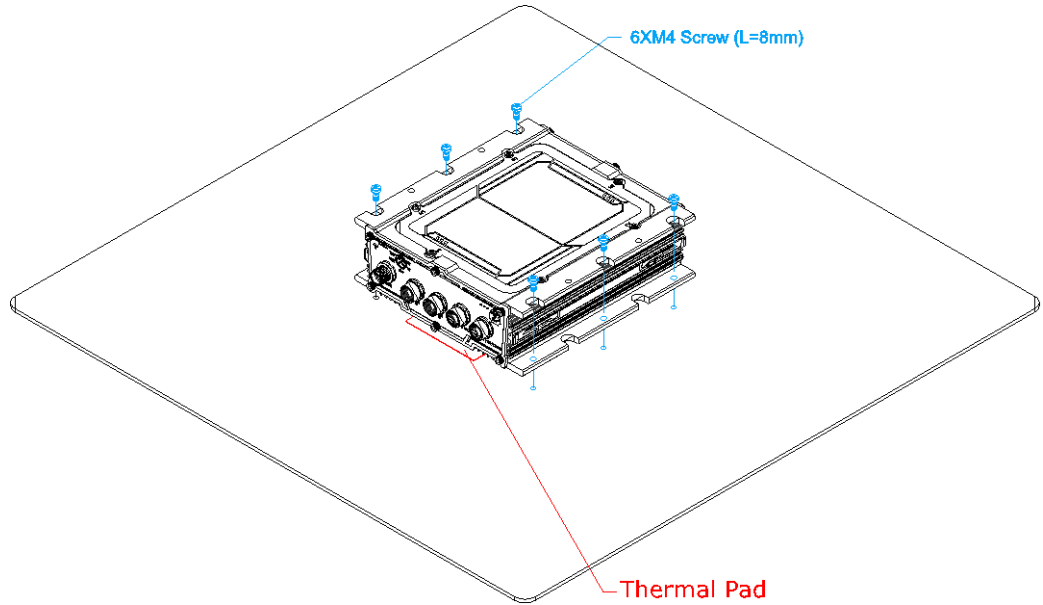

 **NOTE**
 Please note that the M12 connectors must be facing downwards.

3.6 DIN Rail Installation

The DIN rail is easy to install and it is a convenient way to position the system. The DIN rail has been proven to be most beneficial in the industrial environment where space is limited. For installation, please refer to the following instructions.

- To install, The **DIN rail bracket** is secured onto the system using four **M4 P-head screws** (8mm length), and the **DIN rail clip** is secured onto the DIN rail bracket using four **M4 I-head screws** (6mm length).

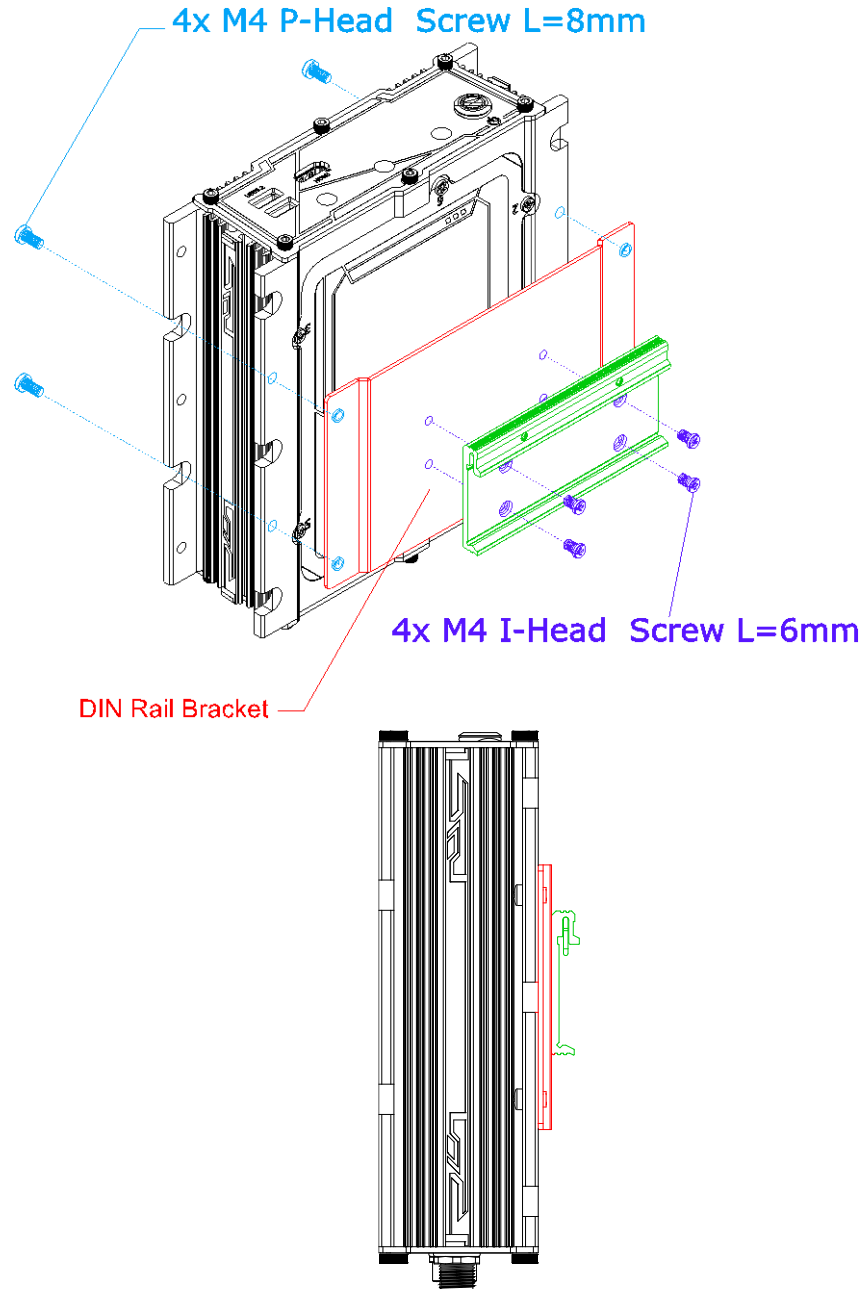

 **NOTE**

Please note that the M12 connectors must be facing downwards.

- To install the DIN rail clip onto the DIN rail, you must come over the top of the DIN rail, overlap the top clip edge of the mount plate onto the DIN rail first, then firmly press the bottom-front of the enclosure to clip the bottom edge of the mount plate.

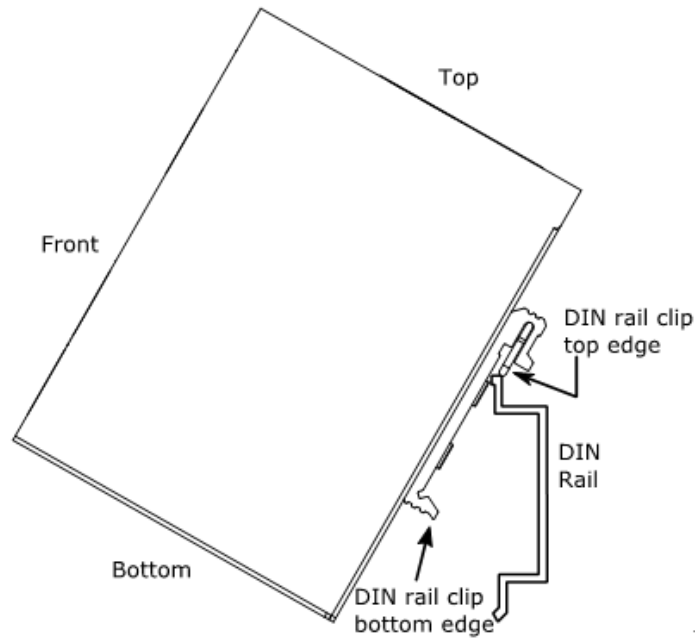

NOTE

Please note that the M12 connectors must be facing downwards.

- Confirm the mount plate has indeed clipped onto the DIN rail for proper fit to complete the installation.

3.7 Powering On the System

There are several methods to power on the system

- Pressing the power button
- Sending a LAN packet via Ethernet (Wake-on-LAN)
- Remote switch mode
- Using the ignition signal input

We will describe the processes and actions involved for the first four methods in this section and the ignition signal input method will be described in section 3.7.

3.7.1 Powering On Using the Power Button

This is the simplest way to turn on your system. The power button on the front panel is a non-latched switch and behaves as the ATX-mode on/off control. With DC power connected, pushing the power button will turn on the system and the PWR LED indicator will light up. Pushing the button when system is on will turn off the system. If your operating system supports ATX power mode (i.e. Microsoft Windows or Linux), pushing the power button while the system is in operation will result in a pre-defined system behavior, such as shutdown or hibernation.

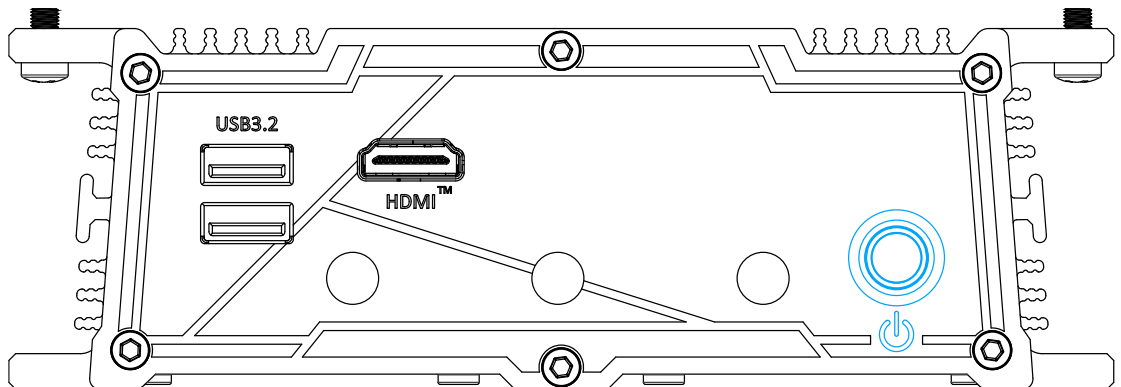

POC-766AWP-DEV

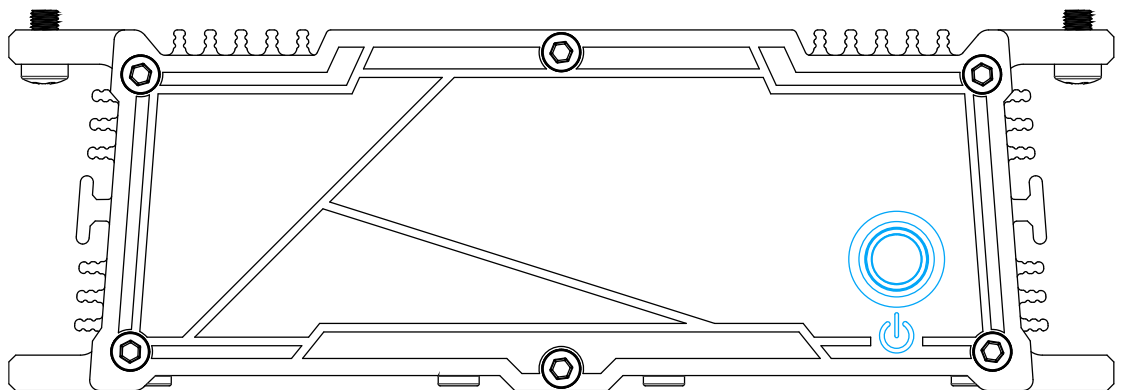

POC-766AWP

3.7.2 Powering On Using Wake-on-LAN

Wake-on-LAN (WOL) is a mechanism to wake up a computer system from a S5 (system off with standby power) state via issuing a magic packet. The system's Wake-on-LAN compatible Ethernet port is shown below.

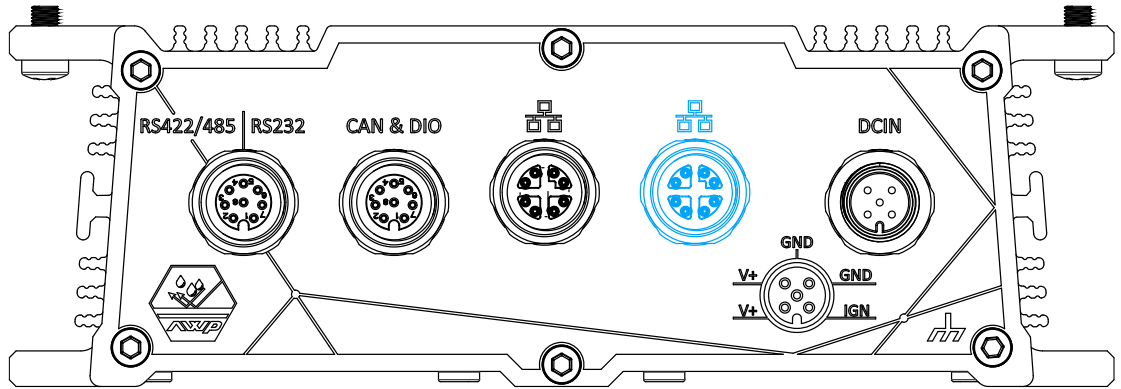

 **NOTE**

Please make sure the Intel chipset and Ethernet driver has been properly installed prior to setting up WOL function.

To enable WOL function, please set up WOL settings in the BIOS and in the operating system by follow the steps described below.

1. When the system boots up, press F2 to enter BIOS setup utility.
2. Go to the **[Power]>[Wake On LAN]** and set it to **[Enabled]**.
3. Press F10 to **“Save changes and exit BIOS”** and allow the system boot into the operating system.
4. Once booted into the Windows system, press **“Windows key + E”**, right-click on **“Network>Properties>Change adapter**

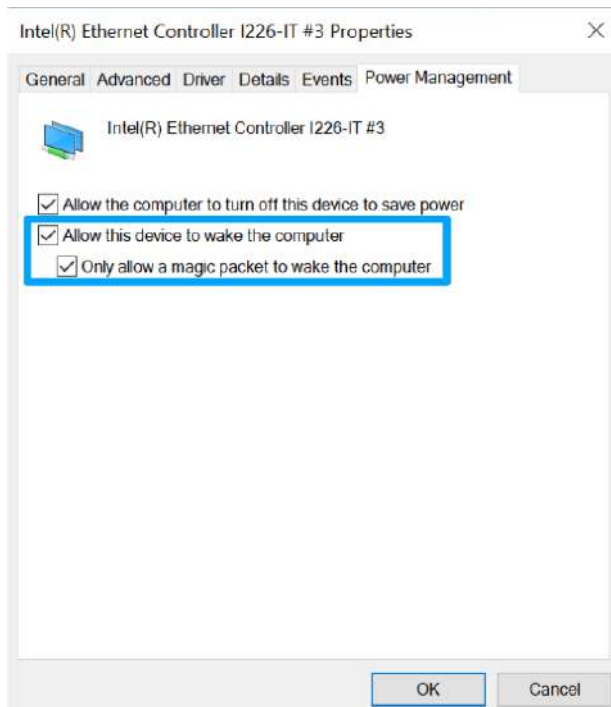

settings". Locate and double-click on the adapter Intel® I226 Gigabit Network Connection, click on **Configure**.

- Click on the **Power Management** tab and check the following options. Click on OK when done.

Magic Packet

The magic packet is a broadcast frame containing anywhere within its payload 6 bytes of all 255 (FF FF FF FF FF FF in hexadecimal), followed by sixteen repetitions of the target computer's 48-bit MAC address.

For example, NIC's 48-bit MAC Address is 78h D0h 04h 0Ah 0Bh 0Ch

DESTINATION SOURCE MISC

FF FF FF FF FF FF

78 D0 04 0A 0B 0C 78 D0 04 0A 0B 0C

78 D0 04 0A 0B 0C 78 D0 04 0A 0B 0C

78 D0 04 0A 0B 0C 78 D0 04 0A 0B 0C

78 D0 04 0A 0B 0C 78 D0 04 0A 0B 0C

78 D0 04 0A 0B 0C 78 D0 04 0A 0B 0C

78 D0 04 0A 0B 0C 78 D0 04 0A 0B 0C

78 D0 04 0A 0B 0C 78 D0 04 0A 0B 0C

78 D0 04 0A 0B 0C 78 D0 04 0A 0B 0C

MISC CRC

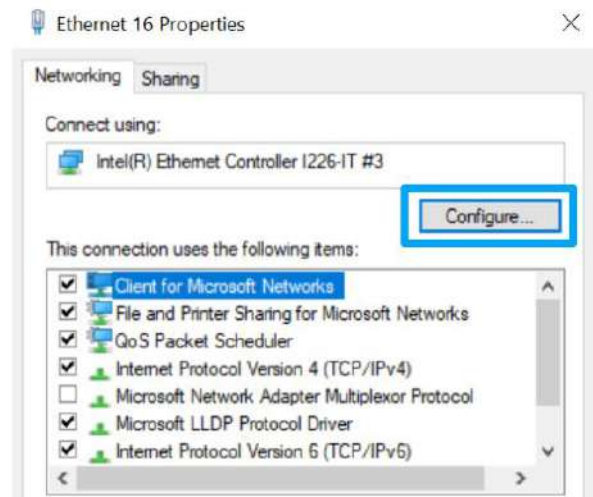

There are some free tools available on Internet that can be used to send a magic packet. Please refer to the following link to understand more about [Magic Packet](#).

3.7.3 Remote Switch Mode

 **NOTE**

Enabling the “Remote Switch Mode” will disable the power button function.

For an application which places the system inside a cabinet, it’s useful to control powering on/off the system using an external switch. The system provides an remote switch mode for connecting a latched/ non-latched switch and behaving either AT-mode or ATX-mode power on/off control.

When using the ATX-mode on/ off control, you need a non-latch switch. The external non-latched switch acts exactly the same as the power button on the front panel. Please follow the steps below to install an external non-latch switch.

1. Acquire a non-latched switch with 2-pin plug.
2. Connect the non-latched switch to the IGN and GND pins.

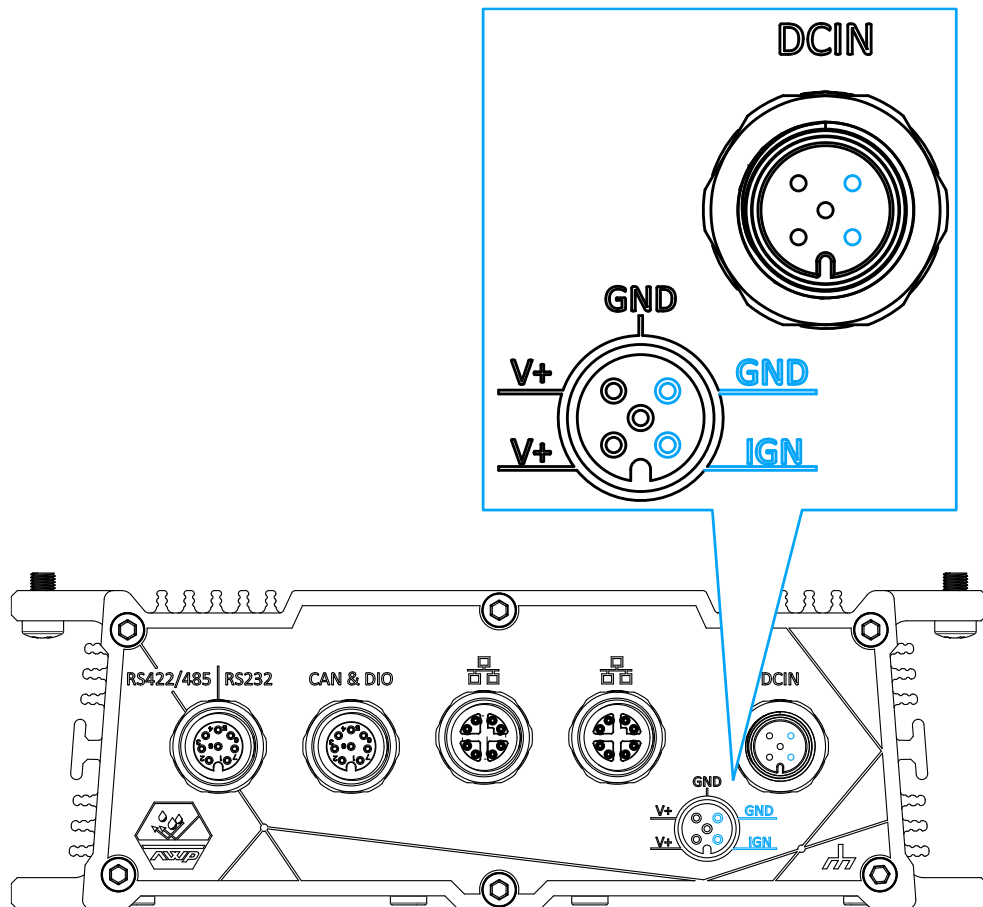

3. You must enable the setting in the BIOS.



To do so,

- Press **F2** when the system boots up to enter the BIOS setup utility.
 - Go to **[Power]** → **[Remote Switch Mode]**.
 - Set it to “Enabled”.
 - Once set, press **F10** to save setting and exit.
4. With DC power connected, pushing the power button will turn on the system. Pushing the button when system is on will turn off the system. If your operating system supports ATX power mode (i.e. Microsoft Windows or Linux), pushing the power button while the system is in operation will result in a pre-defined system behavior, such as shutdown or hibernation.

3.8 Ignition Power Control

The ignition power control module for in-vehicle applications is a MCU-based implementation that monitors the ignition signal and reacts to turn on/off the system according to predefined on/off delay. Its built-in algorithm supports other features such as ultra-low power standby, battery-low protection, system hard-off, etc. In this section, we'll illustrate the principle of ignition power control and operation modes.

3.8.1 Principles of Ignition Power Control

The basic concept of ignition power control module is to control the timing correlation between ignition signal and system power status. A typical timing correlation is described in following diagram.

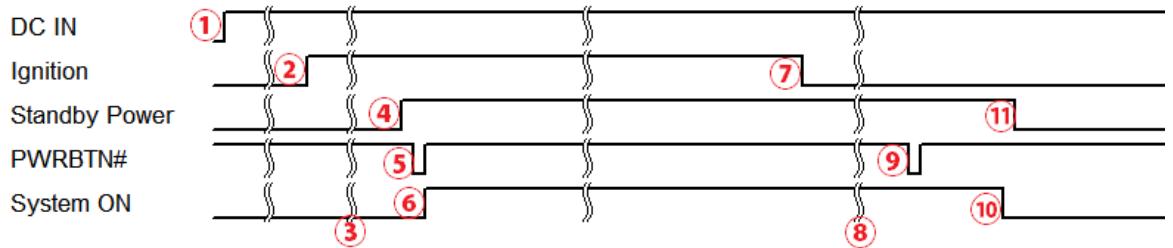

1. When DC power is supplied to the system, MCU starts to periodically detect ignition signal. Note that only MCU is working at this moment and the overall power consumption is less than 2 mW.
2. Ignition signal is active (both 12VDC and 24VDC ignition signals are accepted).
3. MCU starts to count a pre-defined power-on delay.
4. Once power-on delay expired, MCU turns on necessary standby power for the system (3.3VSB & 5VSB).
5. A PWRBTN# pulse is then issued to turn on the system (equivalent to one pressing the power button on the front panel).
6. The system is booting and becomes operational.
7. After a period of time, the ignition signal becomes inactive.
8. MCU starts to count a pre-defined power-off delay.
9. Once power-off delay expired, another PWRBTN# pulse is issued to perform a soft-off for the system (ex. a normal shutdown process for Windows system).
10. The system is completely shut down.
11. As MCU detects system is off, it turns off the standby power for the system, and operates in low power mode again (< 2mW power consumption).

3.8.2 Additional Features of Ignition Power Control

In addition to the typical timing correlation, the ignition power control module offers additional features to provide additional reliability for in-vehicle applications.

- **Low battery detection**

The ignition power control module continuously monitors the voltage of DC input when the system is operational. If input voltage is less than 11V (for 12VDC input) or less than 22V (for 24VDC input) over a 60-second duration, it will shut down the system automatically.

- **Guarded power-on/ power-off delay duration**

If ignition signal goes inactive during the power-on delay duration, the ignition power control module will cancel the power-on delay process and go back to idle status. Likewise if ignition signal goes active during the power-off delay duration, the ignition power control module will cancel the power-off delay process and keep the system running.

- **System hard-off**

In some cases, system may fail to shutdown via a soft-off operation due to system/ application halts. The ignition power control module offers a mechanism called “hard-off” to handle this unexpected condition. By detecting the system status, it can determine whether the system is shutting down normally. If not, the ignition power control module will force cut-off the system power 10 minutes after the power-off delay duration.

- **Smart off-delay**

The ignition power control module offers two modes (mode 6 & mode 7) which have very long power-off delay duration for applications require additional off-line time to process after the vehicle has stopped. In these two modes, the ignition power control module will automatically detect the system status during the power-off delay duration. If the system has shutdown (by the application software) prior to power-off delay expiring, it will cut off the system power immediately to prevent further battery consumption.

3.8.3 Wiring Ignition Signal

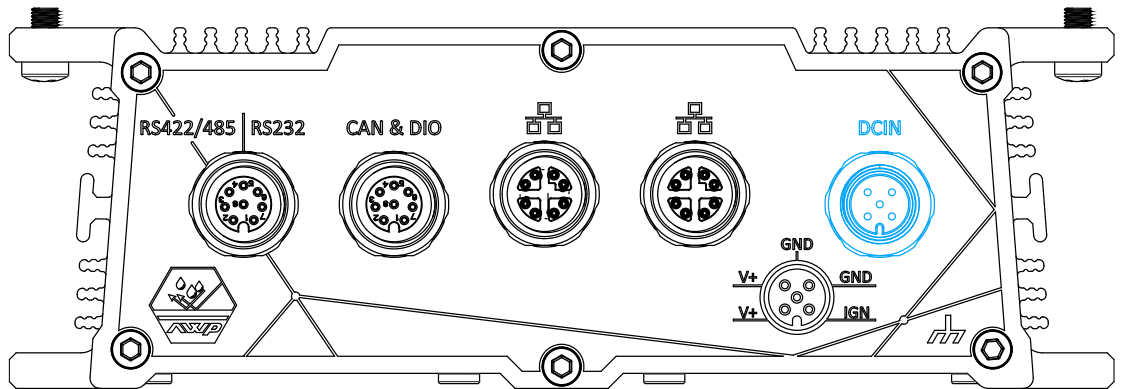

To have ignition power control for in-vehicle usage, you need to supply IGN signal to the system. The IGN input is located on the Pin 2 of the M12 A-coded connector (shared with DC power input). For in-vehicle ignition control wiring, please do the following:

1. Connect car Battery+ line (12V for sedan, 24V for bus/truck) to V+.
2. Connect car Batter-/ GND line to GND.
3. Connect ACC line to IGN.

 **NOTE**

Please make sure your DC power source and IGN signal share the same ground. IGN input accepts 8~35VDC. Supply a voltage higher than 35VDC may damage the system.

3.8.4 Configure your Windows system

When applying ignition power control to your system, please make sure you've configured your Windows system to initiate a shutdown process when pressing the power button. By default, Windows 10 goes to sleep (S3) mode when power button is pressed. As sleep (S3) is not a complete shutdown behavior, the ignition control function does not recognize the finish of a normal shut down process and thus users will encounter a system hard-off (power cut-off after 10 minutes). Please configure "When I press the power button" to "Shut down" in your Windows system settings.

Power button settings

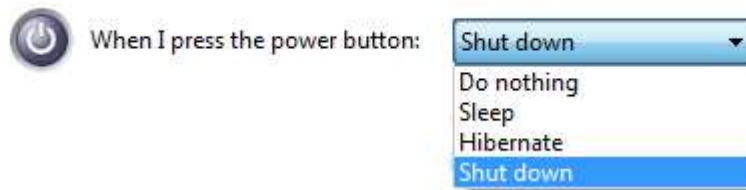

4 BIOS Settings

The system is shipped with factory-default BIOS settings optimized for best performance and compatibility. In this section, we'll illustrate some BIOS settings you may need to set or change prior to operating system installation. Please always make sure you understand the effect of change before you proceed with any changes. If you are unsure of the function you are changing, it is recommended to change one setting at a time to see its effect(s).

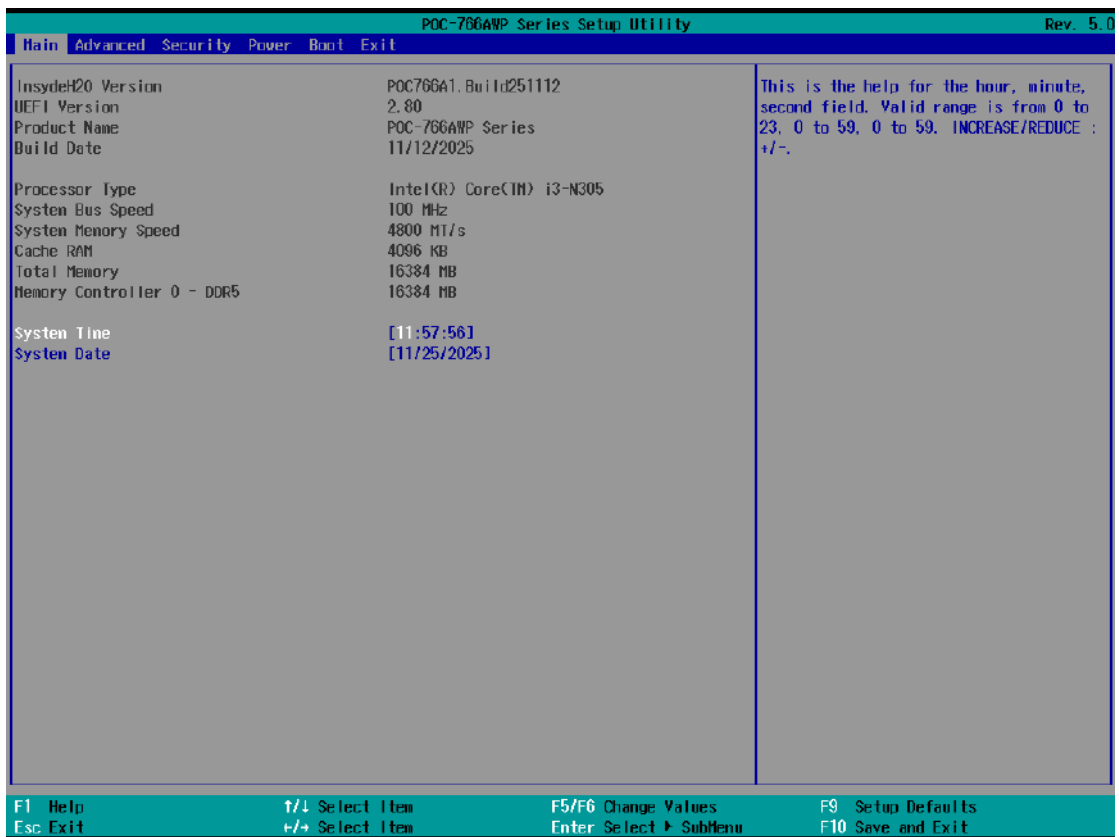

 **NOTE**

Not all BIOS settings will be discussed in this section. If there is a particular BIOS setting you are after but is not discussed in this section, please contact Neousys Technical Support staff.

4.1 COM1 Port Configuration

The system's COM1 port supports RS-232. For RS-422/485 communication, the “RS-422/485 Termination” option determines whether to enable/ disable internal termination of RS-422/485 transceiver according to your wiring configuration (e.g. with or without external termination).

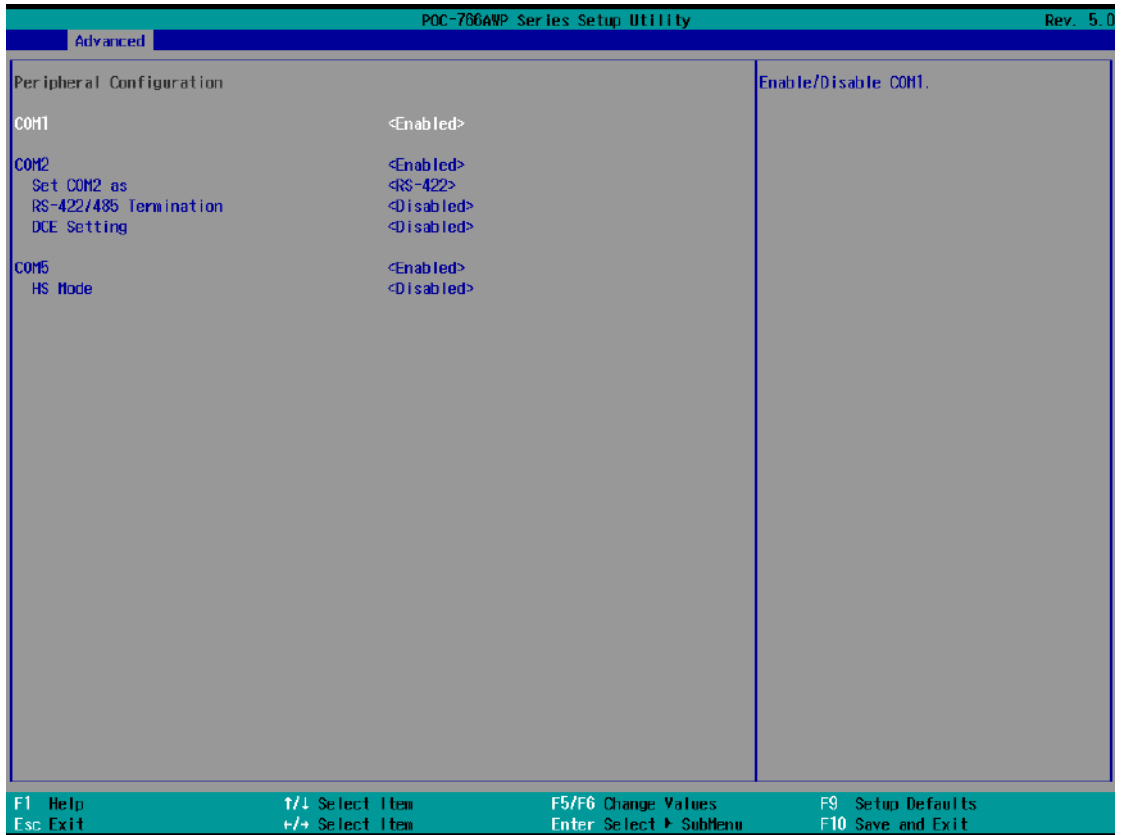

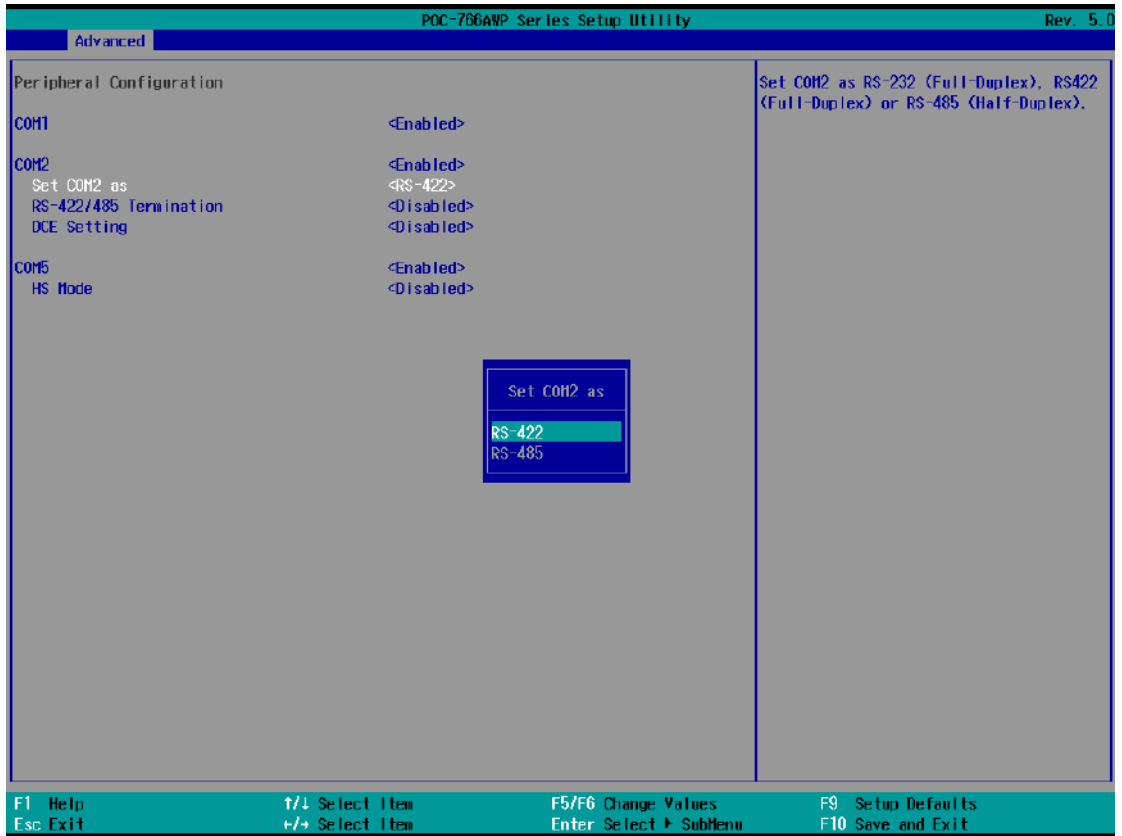

To set COM1&2 operating mode:

1. Press **F2** when the system boots up to enter the BIOS setup utility.
2. Go to **[Advanced]** → **[Peripheral Configuration]**.
3. You can Enable/ Disable COM1 or select COM2 to **[Set COM2 as]** option to the desired mode.
4. Once set, press **F10** to save setting and exit.

4.2 TPM Availability

Trusted Platform Module (TPM) is a hardware-based cryptoprocessor to secure hardware by integrating cryptographic keys into devices. The system is designed with on-board TPM 2.0 module. As TPM 2.0 requires 64-bit Windows 10/ 11 with UEFI boot mode, it is enabled in BIOS by default.



To enable TPM availability:

1. When system boots up, press F2 to enter BIOS setup utility.
2. Go to **[Security] > [TPM Availability]**, press ENTER to bring up Options, Available/ Hidden.
3. Highlight your selection, press Enter and press F10 to "Exit Saving Changes".

4.3 C-States

C-States is a power-saving technique implemented in modern Intel processors. It shuts down the clock signals and power for idle logic units inside the CPU to save the energy consumed. The trade-off, however, is a longer latency for CPU to wake up and be 100% operational. Depending on your application, you can configure these options to have higher performance (disable “C-States”) or lower power-consumption (enable “C-States”).

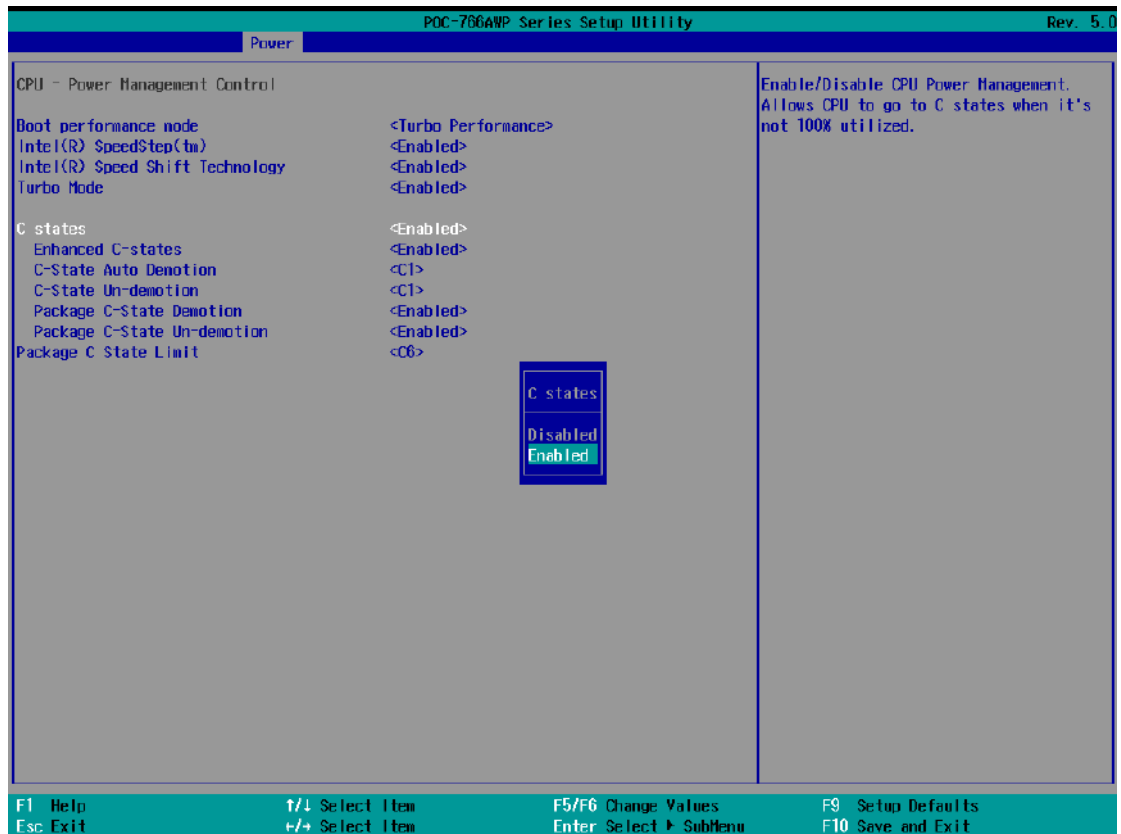

To set C-States and Enhanced C-States:

1. Press **F2** when the system boots up to enter the BIOS setup utility.
2. Go to **[Power] → [CPU Configuration] → [CPU Power Management]**
3. Enable/disable the **[C-States]** option according to your application.
4. Once set, press **F10** to save setting and exit.

4.4 Wake-on-LAN

Wake-on-LAN (WOL) is a mechanism which allows you to turn on your system via Ethernet connection. To utilize Wake-on-LAN function, you have to enable this option first in BIOS settings. Please refer to Powering on via Wake-on-LAN function.

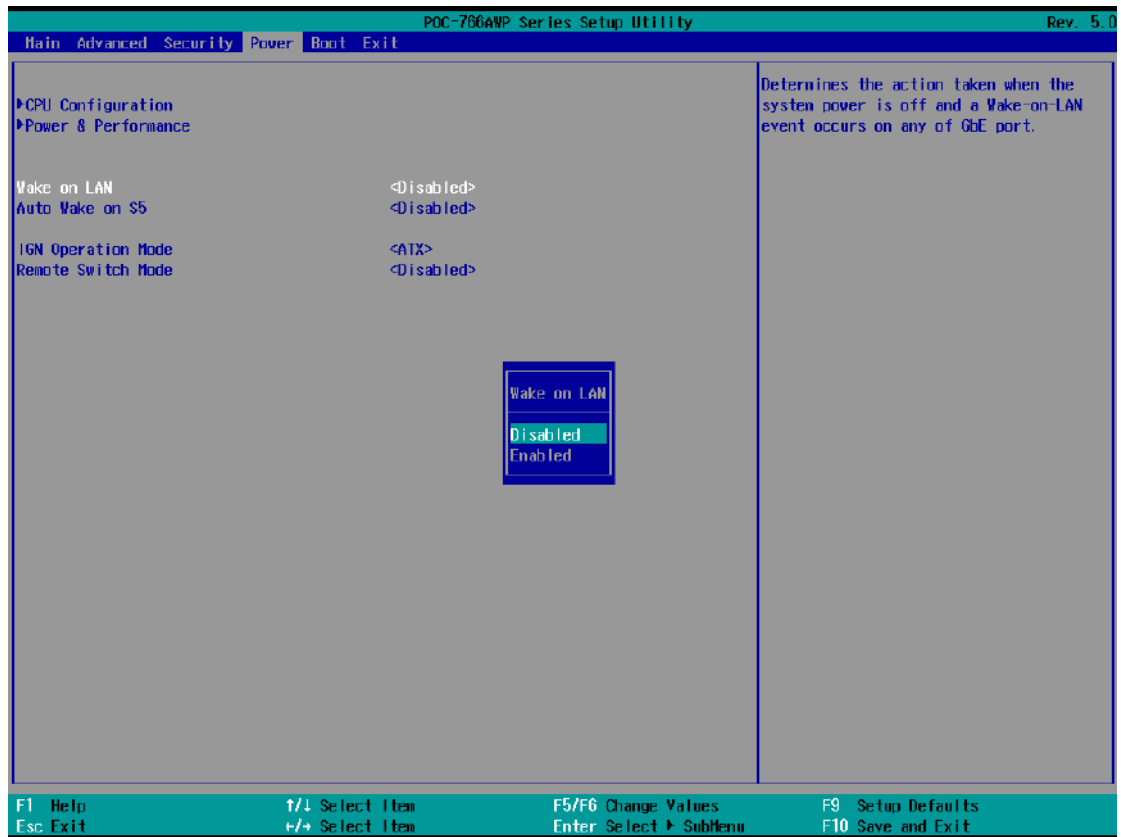

To enable/disable “Wake on LAN” option:

1. Press **F2** when the system boots up to enter the BIOS setup utility.
2. Go to [**Power**].
3. You may enable/disable the [**Wake on LAN**] option.
4. Once set, press **F10** to save setting and exit.

4.5 Ignition Power Control

The system feature ignition power control. It monitors the ignition signal and reacts to turn on/off the system according to predefined on/off delay. Its built-in algorithm supports other features such as smart off delay, low battery threshold, system hard-off, etc. By default, it is set to “**Auto-on**”, but the ignition control settings can be configured in the BIOS, and to do so, please refer to the following instructions:



NOTE

The ignition settings will not reset when you flash the BIOS. To reset the ignition settings, please Load Default Settings, press F10 to Save and Exit, and press the power button to turn the system to complete the reset procedure.

To configure the ignition power control settings:

1. Press **F2** when the system boots up to enter the BIOS setup utility.
2. Go to **[Power] > [Ignition Power Control]** and press Enter.
3. Highlight **[IGN Operation Mode]** and select the setting you desire

Setting	Description
[ATX]	The power button turns on/ off the system without delay.
[Auto-on]	The system powers on automatically when DC power is supplied
[IGN]	User set power on/ off delay settings.
[Always on]	The system remains powered on permanently.

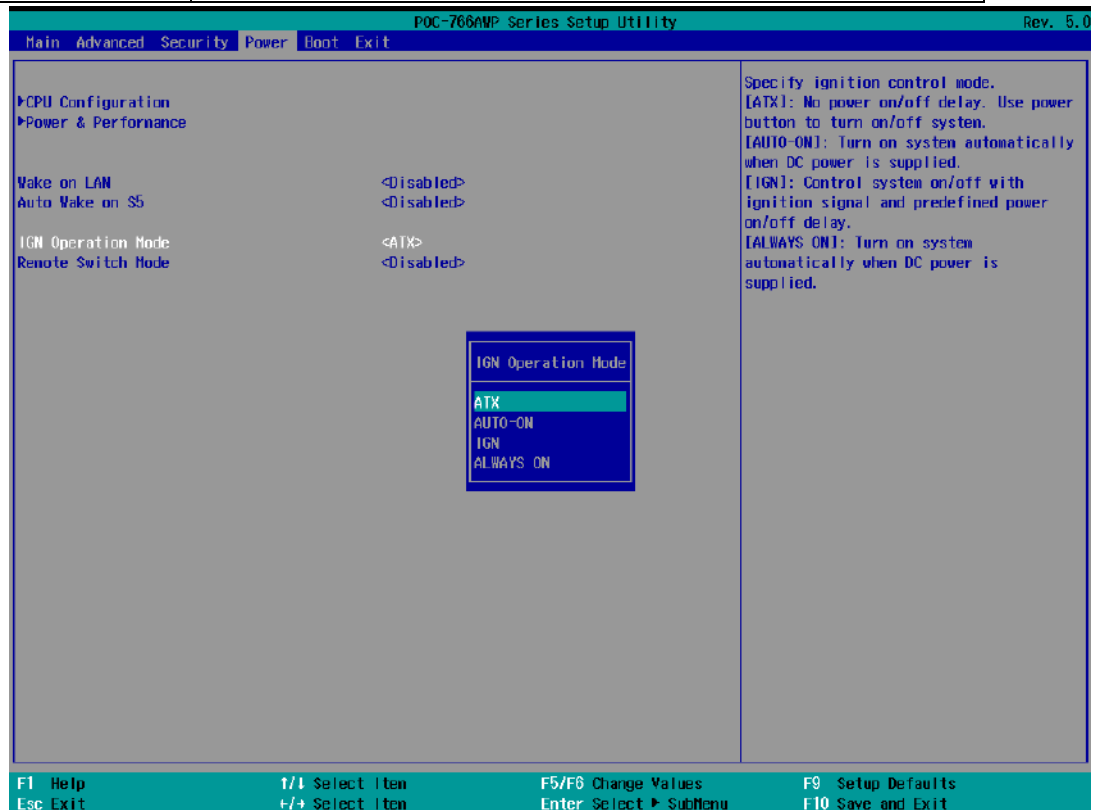

4. The ignition power on delay has the following predefined settings.

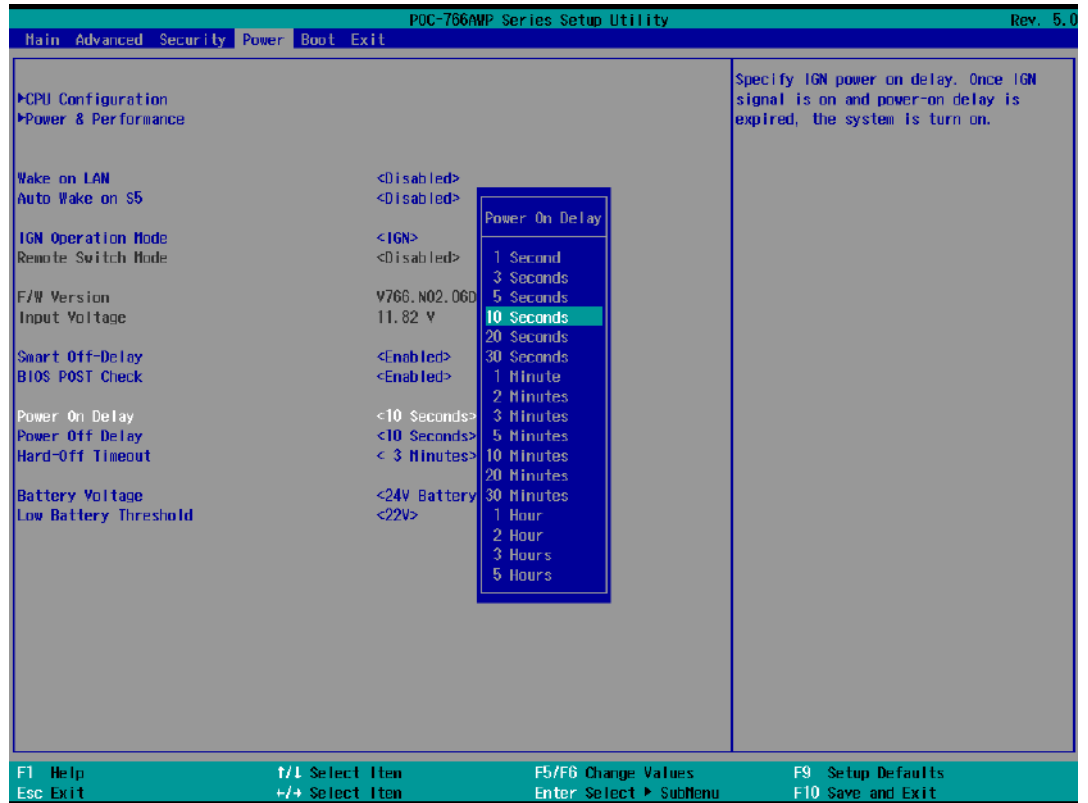

5. The ignition power off delay has the following predefined settings.

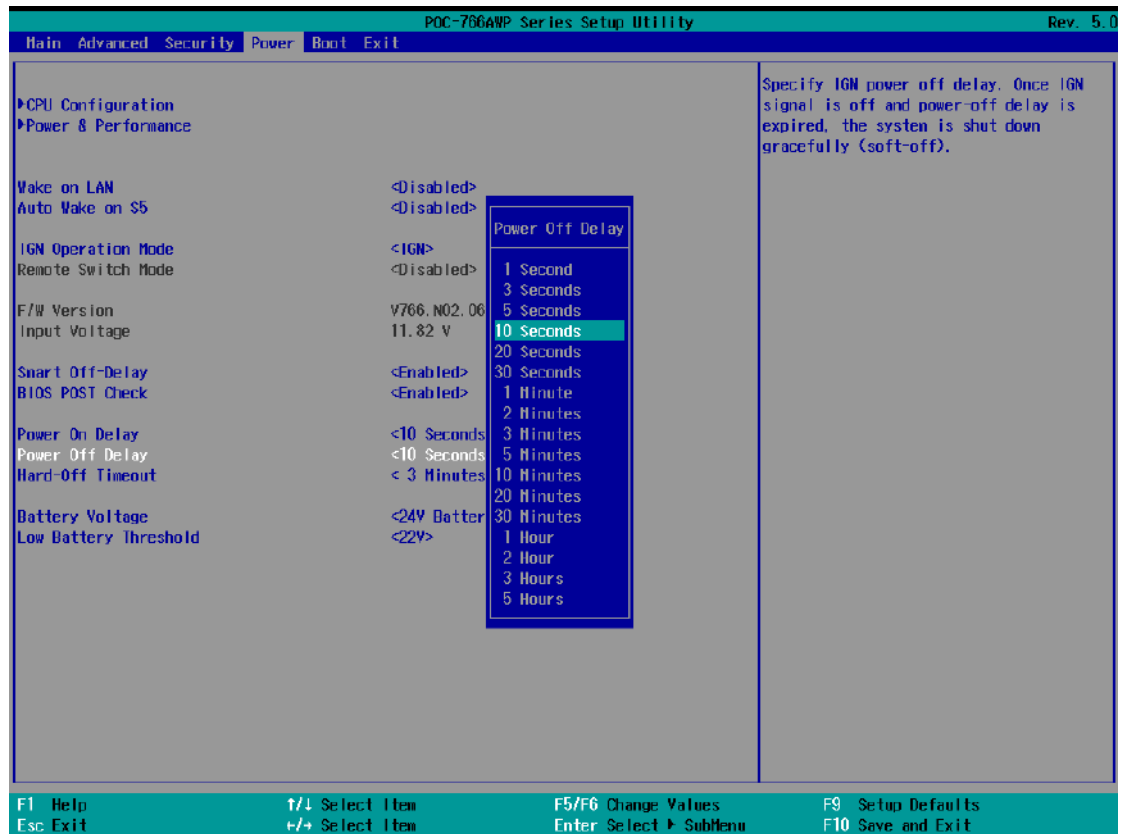

6. The hard-off timeout has the following predefined settings.

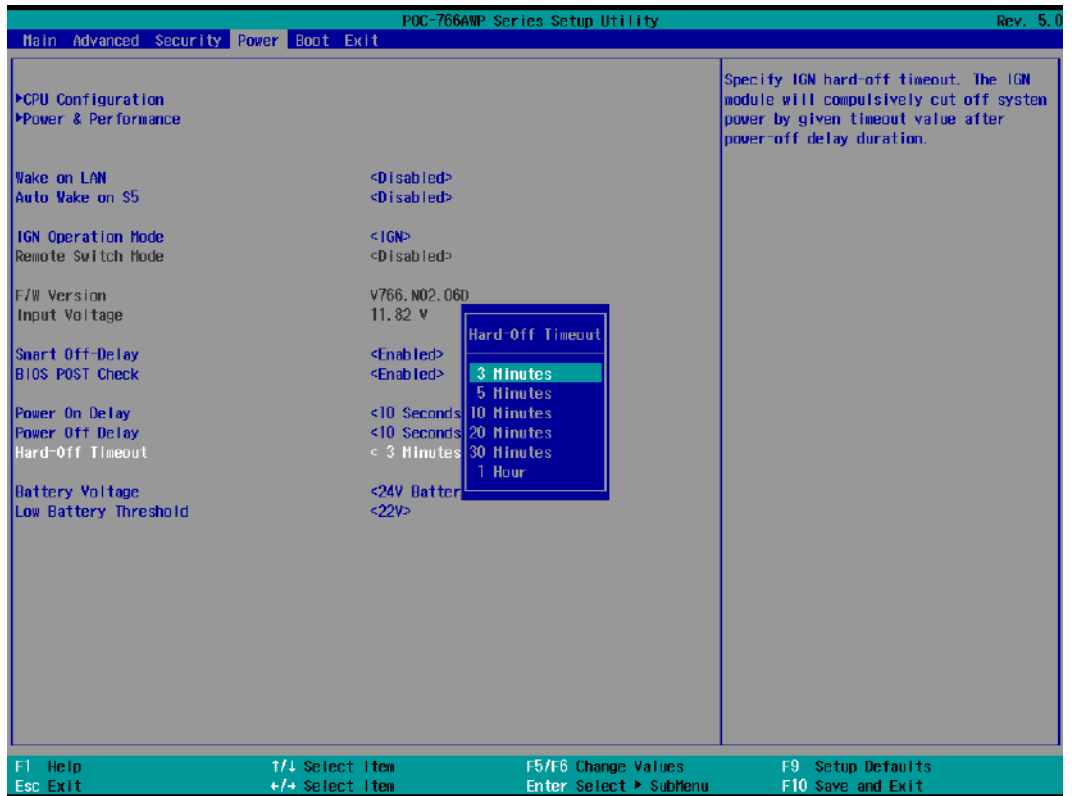

7. You may also set the input battery voltage to correspond to the voltage supplied by your vehicle by highlighting [**Battery Voltage**], and press Enter to bring up the options [**12v or 24v Battery**].

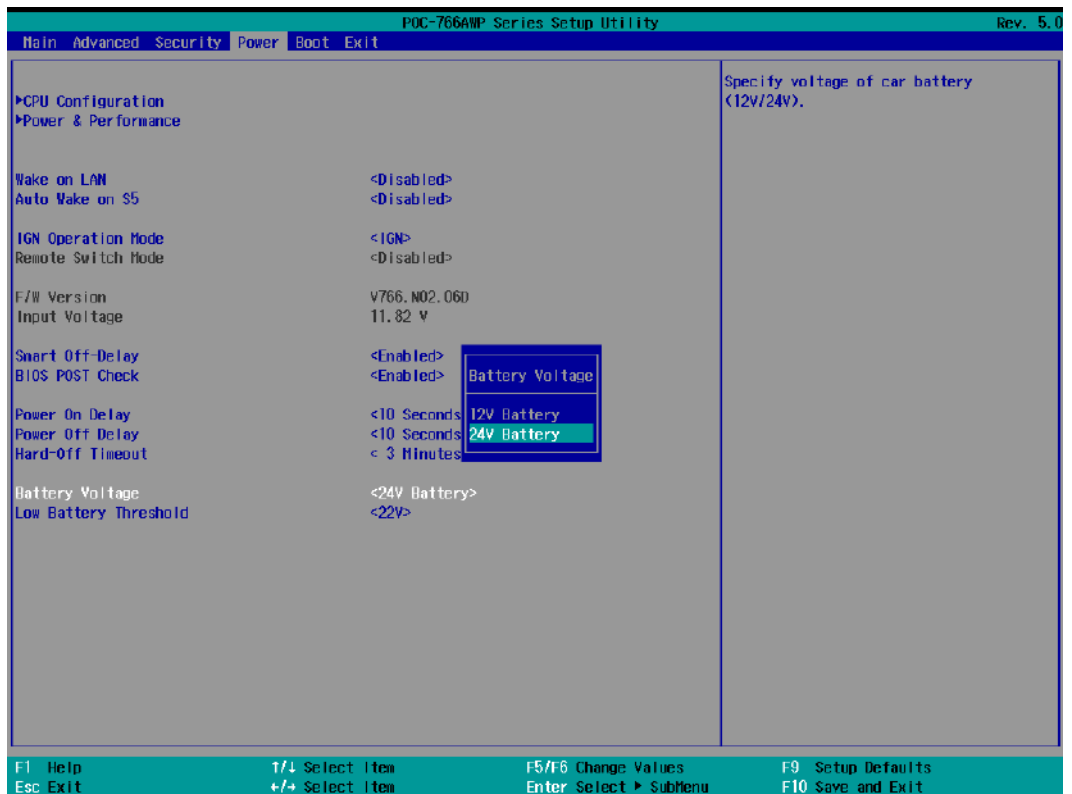

8. [Low Battery Threshold] setting can also be set.

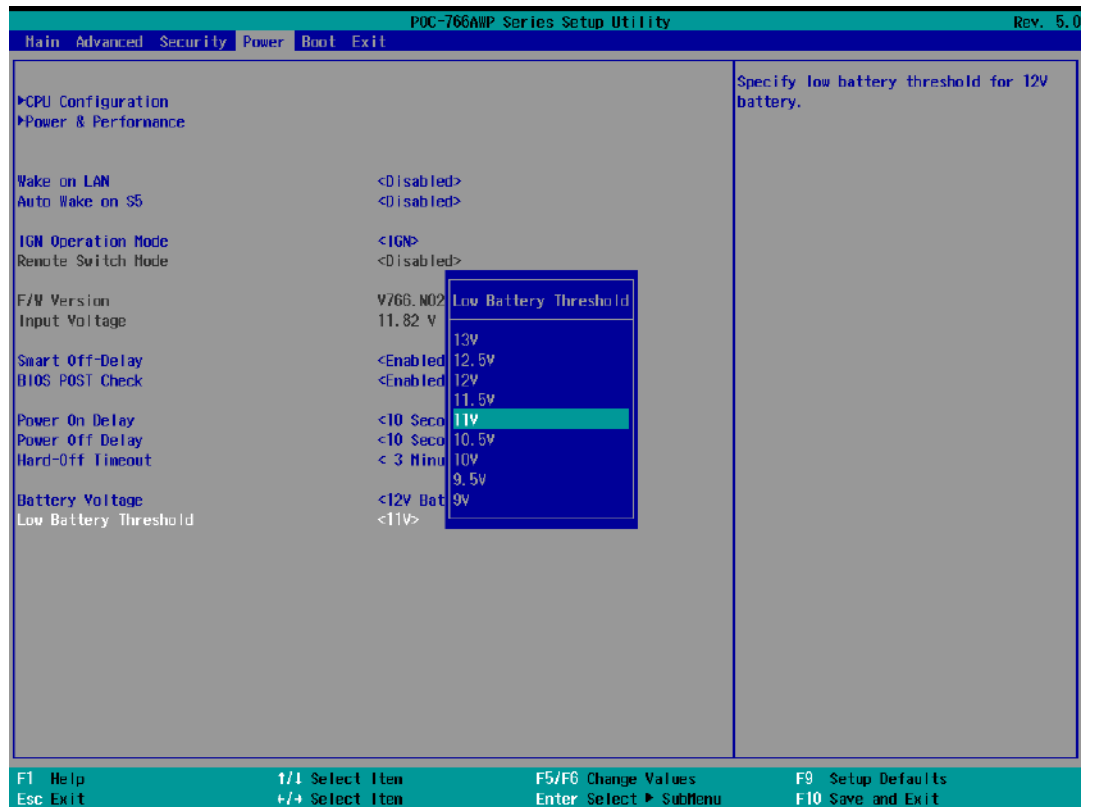

12V battery: low battery threshold settings

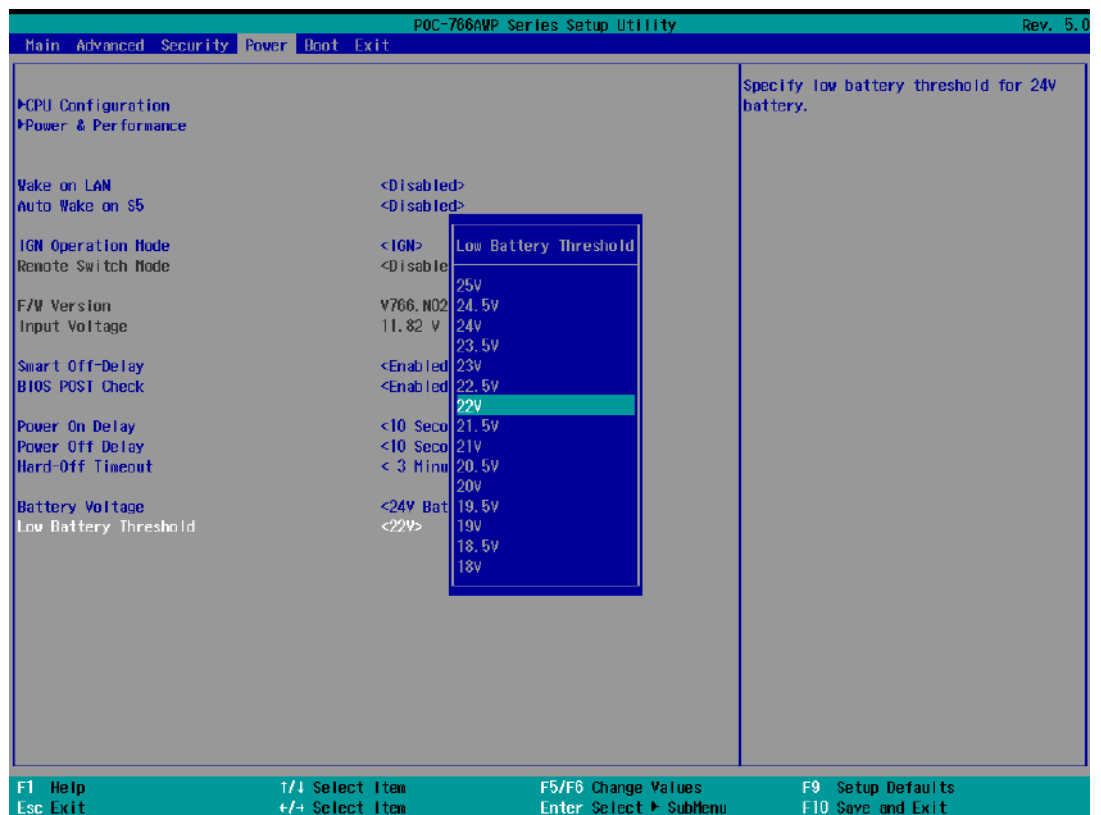

24V battery: low battery threshold settings

9. Press F10 to “Exit Saving Changes”.

4.6 Auto Wake on S5

When the system is set to operate in S5 state, the user can specify a time to turn on the system, daily or monthly.

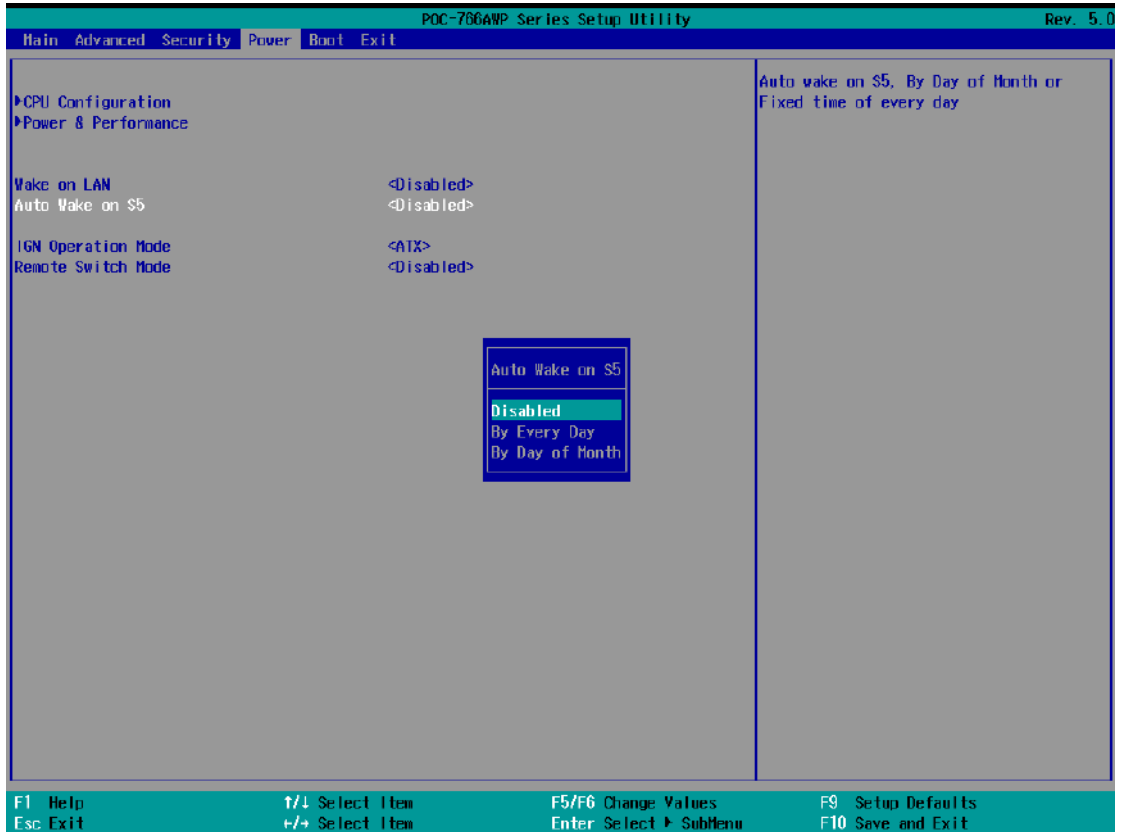

Value	Option	Description
Auto Wake on S5	Disabled	The system does not turn on when operating in state S5.
	By Every Day	The system turns on each day when operating in state S5. Specify the time of day.
	By Day of Month	The system turns on each month when operating in state S5. Specify the day and time.

To set:

1. Press **F2** when the system boots up to enter the BIOS setup utility.
2. Go to **[Power] > [Auto Wake on S5]**.
3. Highlight your selection, and press ENTER.
4. Once set, press **F10** to save setting and exit.

4.7 Boot Menu

The Boot menu in BIOS allows you to specify the system’s boot characteristics by setting bootable device components (boot media) and method. Or, you may press F12 upon system start up and select a device you wish boot from.

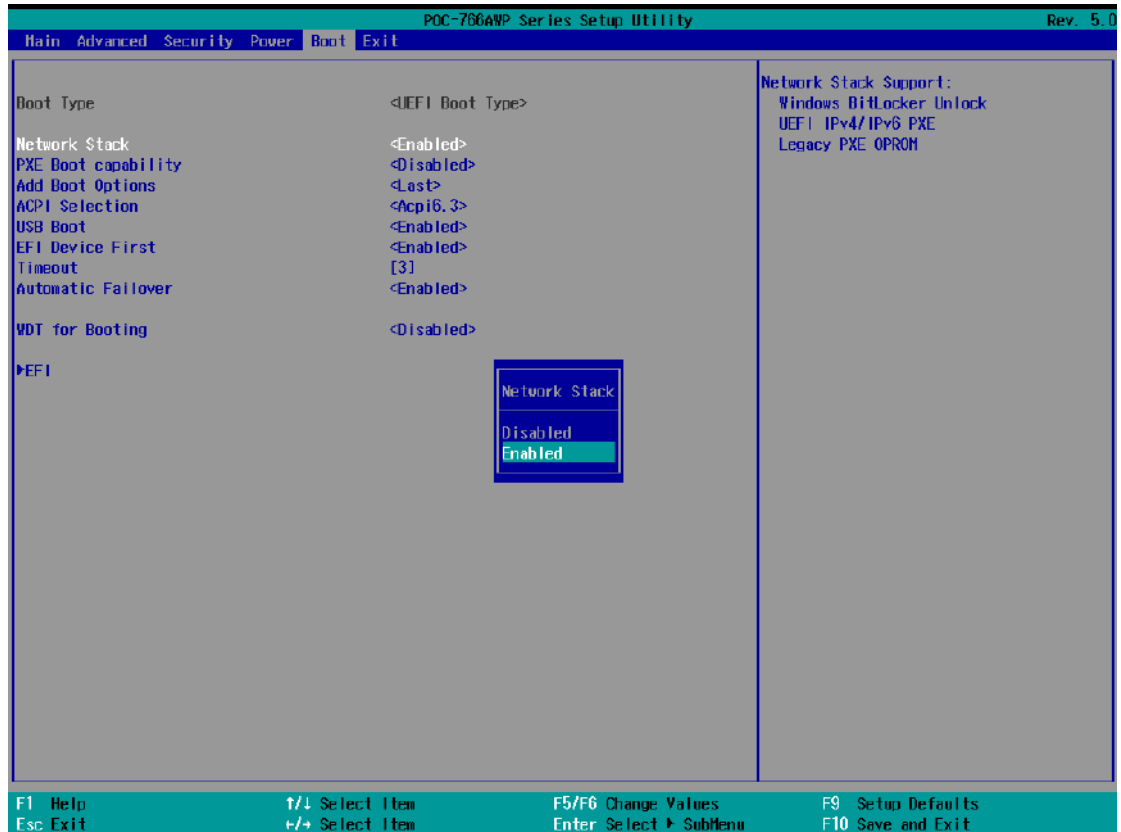

Value	Option	Description
Boot Type	UEFI Boot Type	Only UEFI boot media listed are approved as boot media.
Network Stack	Enabled	The system is available for network access using UEFI.
	Disabled	The system is not available for network access using UEFI.
PXE Boot capability	Disabled	The BIOS does not initialize the PXE option ROM
	Enabled	The BIOS/UEFI will initialize the Intel Boot Agent for each I226-IT NIC.
Add Boot Options	First	Newly detected boot media are placed at the top of the boot order.
	Last	Newly detected boot media are placed at the bottom of the boot order.
ACPI	1.0B/ 3.0/	Advanced Configuration and Power Interface allows the

Selection	4.0/ 5.0/ 6..3	operating system to control system power management
USB Boot	Enabled	Allow boot from bootable USB devices.
	Disabled	Does not allow boot from bootable USB devices
EFI Device First	Enabled	The system will prioritize booting from UEFI boot devices over legacy/CSM boot devices.
	Disabled	The system will try booting from legacy/CSM devices first.
Timeout	1, 2, 3, etc (in seconds)	Boot delay time in seconds to give the user time to activate the hotkey to access the BIOS
Automatic Failover	Enabled	Automatically checks for the next bootable device when the set default device fails.
	Disabled	Will only boot from the designated device.
WDT for booting	Disabled, 1, 3, 5, 10 (minutes)	WDT ensures a successful system boot by specifying a timeout value
EFI	NA	Extensible Firmware Interface

4.8 Add Boot Options (Position New Boot Device)

The “Add Boot Options” allow you to determine whether a newly added device (eg. USB flash disk) is to boot as the first device to boot or the last in the boot sequence.

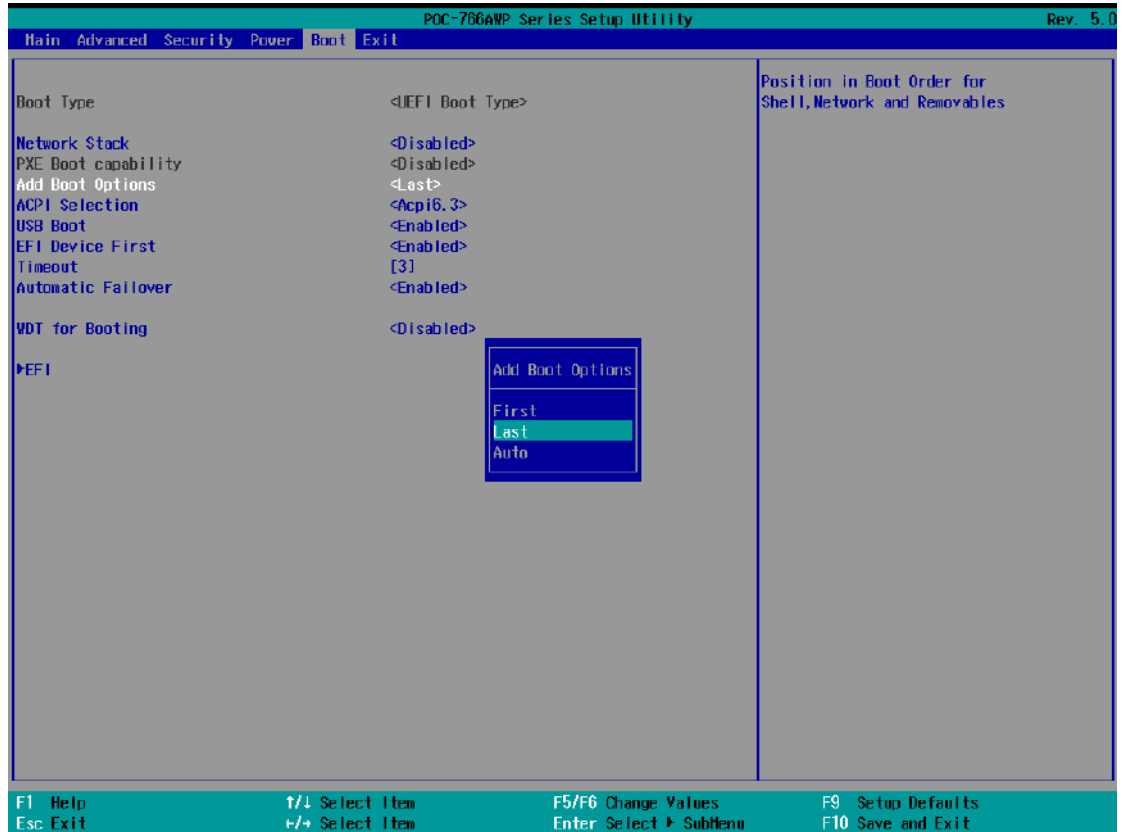

To set the newly-installed boot device as the first or last boot device:

1. Press **F2** when the system boots up to enter the BIOS setup utility.
2. Go to **[Boot] > [Add Boot Options]** menu.
3. Select **[First]** or **[Last]** for your newly-added boot device and press Enter.
4. Once set, press **F10** to save setting and exit.

4.9 Watchdog Timer

The watchdog timer secures the boot process by means of a timer. Once the timer expires, a reset command is issued to initiate another booting process. There are two options in BIOS menu, “*Automatically after POST*” and “*Manually after Entering OS*”. When “*Automatically after POST*” is selected, the BIOS automatically stops the watchdog timer after POST (Power-On Self Test) OK. When “*Manually after Entering OS*” is selected, the user must stop the watchdog timer once booted into the OS. This guarantees the system can always boot into the OS, otherwise another booting process will be initiated. For information about programming watchdog timer, please refer to [Appendix A Using WDT & DIO](#).

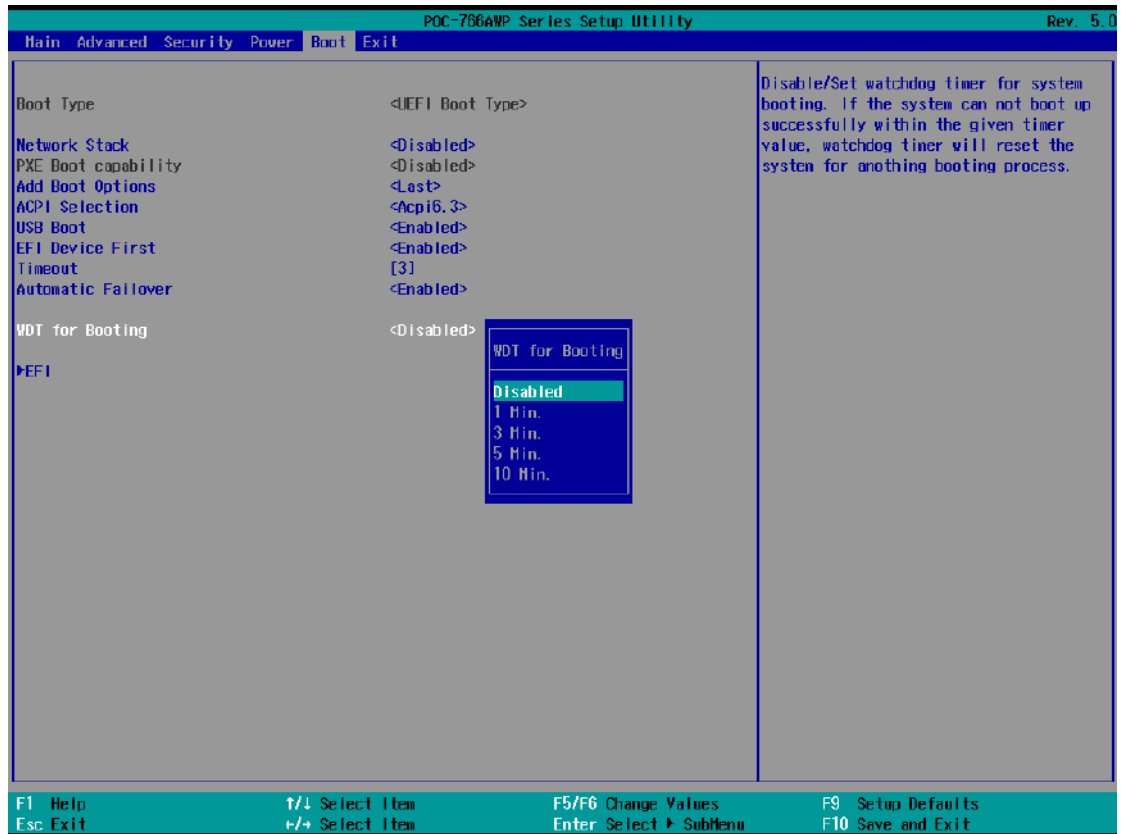

To set the watchdog timer for boot in BIOS:

1. Press **F2** when the system boots up to enter the BIOS setup utility.
2. Go to **[Boot]** menu.
3. Disable or select timeout value for **[WDT for Booting]** option.
4. Once you set a timeout value, the **[WDT Stop Option]** option appears. You can select either “*Automatically after POST*” or “*Manually after Entering OS*”.
5. Once set, press **F10** to save setting and exit.

5 OS Support and Driver Installation

5.1 Operating System Compatibility

POC-766AWP series only provide driver support for the following operating systems. The following list contains the operating systems which have been tested in Neosys Technology Inc.

- Microsoft Windows 10 LTSC 21H2
- Microsoft Windows 11 LTSC 24H2
- Ubuntu 22.04.2 LTS or other distribution with kernel version ≥ 5.19 */**



NOTE

**For Linux system, user may need to manually compile and install the driver for Intel graphics or I226 controller if the driver is not embedded in kernel. You can visit Intel website for further information.*

***For distributions, graphics driver may not be completely implemented in its kernel. You may encounter restrictions when using these features, such as multiple independent displays. For optimum operation, it is the users' responsibility to manually check for new drivers and upgrades!*

Neosys may remove or update operating system compatibility without prior notice. Please contact us if your operating system of choice is not on the list.

5.2 Driver Installation

The system drivers are available online, please click on this [link](#) to download the drivers.

5.3 Driver for Watchdog Timer and DIO

Neosys provides a driver package which contain function APIs for Watchdog Timer control function. You should install the driver package (WDT_DIO_Setup.exe) in prior to use these functions. Please download the latest version of WDT_DIO_Setup.exe to ensure compatibility.

Please refer to this [link](#) to download WDT_DIO.

Appendix A Using WDT & DIO

The watchdog timer (WDT) function ensures reliable system operation. The WDT is a hardware mechanism to reset the system if the watchdog timer is expired. Users can start the WDT and keeping resetting the timer to make sure the system or program is running. Otherwise, the system shall be reset.

In this section, we'll illustrate how to use the function library provided by Neosys to program the WDT functions. Currently, WDT driver library supports Windows 10 x64 and WOW64 platform. For other OS support, please contact Neosys Technology for further information.

Installing WDT_DIO Library

The WDT_DIO function library is delivered in the form of a setup package named **WDT_DIO_Setup.exe**. In prior to program WDT, you should execute the setup program and install the WDT library. Please use the following WDT_DIO_Setup packages according to your operating systems and application.



NOTE

Please download from Neosys website and install the latest WDT_DIO_Setup.exe file.

WDT and DIO Library Installation

WDT_DIO_Setup.2.4.0.0.exe will be used as an example to demonstrate WDT & DIO Library installation setup process. Please refer to the instructions below.

1. Execute **WDT_DIO_Setup.2.4.0.0.exe**.

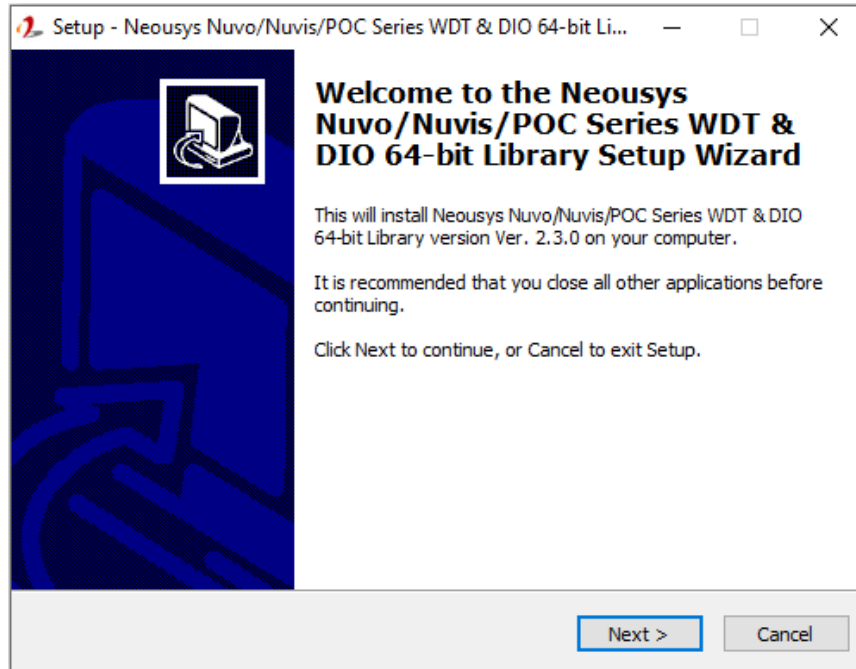

2. Click "Next >" and specify the directory of installing related files. The default directory is *C:\Neosys\WDT_DIO*.

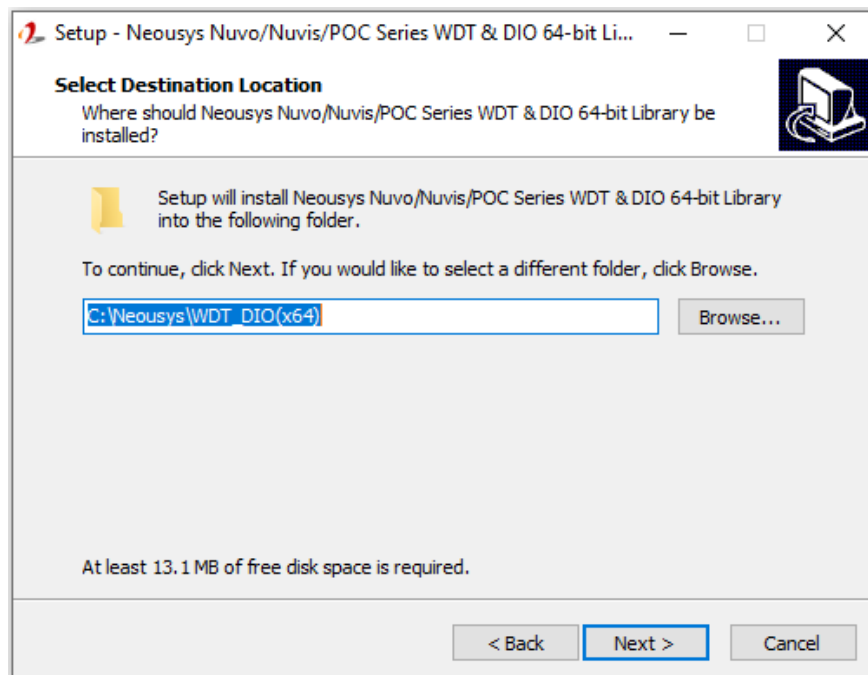

- Once the installation has finished, a dialog will appear to prompt you to reboot the system. The WDT & DIO library will take effect after the system has rebooted.

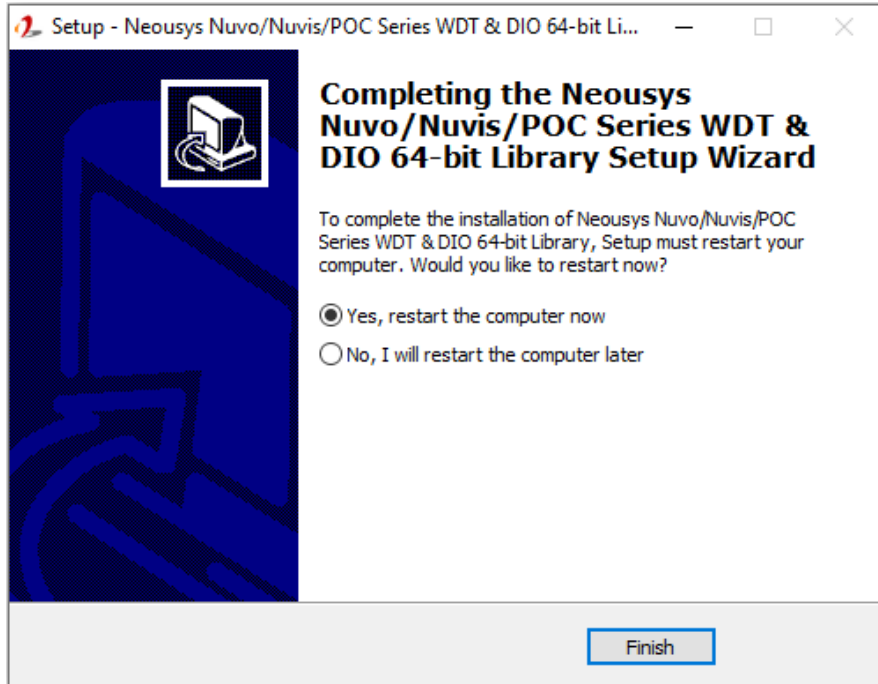

- When programming your WDT or DIO program, the related files are located in

Header File:	\\Include
Library File:	\\Lib
Function Reference:	\\Manual
Sample Code:	\\Sample\\WDT_Demo (Demo for Watchdog Timer) \\Sample\\DIO_Demo (Demo for isolated DIO Control) \\Sample\\COS_Demo (Demo for change-of-state DI)

WDT Function Reference

InitWDT

Syntax	BOOL InitWDT(void);
Description:	Initialize the WDT function. You should always invoke InitWDT() before set or start watchdog timer.
Parameter	None
Return Value	TRUE: Successfully initialized FALSE: Failed to initialize
Usage	BOOL bRet = InitWDT()

SetWDT

Syntax	BOOL SetWDT(WORD tick, BYTE unit);
Description	Set timeout value and unit for watchdog timer. When InitWDT() is invoked, a default timeout value of 255 seconds is assigned.
Parameter	<i>tick</i> WORD value (1 ~ 65535) to indicate timeout ticks. <i>unit</i> BYTE value (0 or 1) to indicate unit of timeout ticks. 0 : unit is minute 1: unit is second
Return Value	If value of unit is correct (0 or 1), this function returns TRUE, otherwise FALSE.
Usage	WORD tick=255; BYTE unit=1; //unit is second. BOOL bRet = SetWDT(tick, unit); //timeout value is 255 seconds

StartWDT

Syntax	BOOL StartWDT(void);
Description	Starts WDT countdown. Once started, the WDT LED indicator will begin blinking. If ResetWDT() or StopWDT is not invoked before WDT countdowns to 0, the WDT expires and the system resets.
Parameter	None
Return Value	If the timeout value is given in correct format (WDT started), this function returns TRUE, otherwise FALSE
Usage	BOOL bRet = StartWDT();

ResetWDT

Syntax	BOOL ResetWDT(void);
Description	Reset the timeout value to the value given by SetWDT().If ResetWDT() or StopWDT is not invoked before WDT countdowns to 0, the WDT expires and the system resets.
Parameter	None
Return Value	Always returns TRUE
Usage	BOOL bRet = ResetWDT();

StopWDT

Syntax	BOOL StopWDT(void);
Description	Stops the countdown of WDT. When WDT has stopped, the WDT LED indicator stops blinking.
Parameter	None
Return Value	Always returns TRUE
Usage	BOOL bRet = StopWDT();

DIO Functions

InitDIO

Syntax	BOOL InitDIO(void);
Description	Initialize the DIO function. You should always invoke InitDIO() before write/read any DIO port/channel.
Parameter	None
Return Value	Returns TRUE if initialization successes, FALSE if initialization failed.
Usage	BOOL bRet = InitWDT();

DIReadLine

Syntax	BOOL DIReadLine(BYTE ch);
Description	Read a single channel of isolated digital input.
Parameter	ch BYTE value specifies the DI channel to be read. <i>Ch</i> should be a value of 0.
Return Value	The status (TRUE or FALSE) of the specified DI channel.
Usage	BYTE ch=3; //DI channel #3 BOOL DIChValue = DIReadLine(ch); //read DI channel #3

DIReadPort

Syntax	WORD DIReadPort(void);
Description	Read the entire isolated digital input port (1 channel).
Parameter	None
Return Value	A WORD value (0~255) indicates the status of DI port (1 DI channel).
Usage	WORD DIPortValue = DIReadPort ();

DOWriteLine

Syntax	void DOWriteLine(BYTE ch, BOOL value);
Description	Write a single channel of isolated digital output.
Parameter	<p>ch BYTE value specifies the DO channel to be written. <i>Ch</i> should be a value of 0 ~ 1.</p> <p>value BOOL value (TRUE or FALSE) specifies the status of DO channel.</p>
Return Value	None
Usage	<pre> BYTE ch=3; //DI channel #3 BOOL DOChValue=TRUE; DOWriteLine(ch, DOChValue); //write DO channel #3 as TRUE </pre>

DOWritePort

Syntax	void DOWritePort(WORD value);
Description	Write the entire isolated digital output port (8 channels).
Parameter	<p>value WORD value specifies the status of the DO port. <i>Value</i> should be a value of 0~255.</p>
Return Value	None
Usage	<pre> WORD DOPortValue=0XFF; //11111111b DOWritePort(DOPortValue); //write DO port as 11111111b </pre>