

# **Neousys Technology Inc.**

**POC-900 Series**

**User Manual**

Revision 1.2

# Table of Contents

Table of Contents .....	2
Legal Information .....	4
Contact Information .....	5
Declaration of Conformity .....	5
Copyright Notice .....	6
Safety Precautions .....	7
Mesures de sécurité .....	8
Service and Maintenance .....	9
Avertissement concernant les piles .....	9
Hot Surface Warning .....	10
Surface chaude .....	10
Battery Warning .....	11
Entretien et réparation .....	11
ESD Precautions .....	12
Précautions nécessaires de décharge électrostatique (ESD) .....	12
Restricted Access Location .....	13
Lieu d'accès restreint .....	13
About This Manual .....	14

## 1 Introduction

1.1 Specification of POC-915 .....	16
1.2 Dimension .....	18
1.2.1 Superior View .....	18
1.2.2 Front Panel View .....	18
1.2.3 COM Port Panel View .....	19
1.2.4 Bottom View .....	19
1.3 POC-900 Series Mounting Options .....	20
1.3.1 DIN-Rail Mount Clip .....	20
1.3.2 Wall Mount (Optional) .....	21
1.3.3 Vertical Wall Mount (Optional) .....	22

## 2 System Overview

2.1 Unpacking the System .....	23
2.2 POC-900 Series Front Panel .....	24
2.2.1 3.5mm Microphone-In/ Speaker-Out Jack .....	25
2.2.2 System Status LED .....	25
2.2.3 HDMI™ Port .....	26
2.2.4 USB3.2 Gen2x1 Port .....	27
2.2.5 Reset Button .....	27
2.2.6 GbE PoE+ Port .....	28
2.2.7 3-Pin Terminal Block .....	29
2.2.8 3-Pin Remote On/ Off .....	29
2.3 POC-900 Series COM Port Panel .....	30
2.3.1 Digital Input/ Output .....	31
2.3.2 COM 1 Port .....	34
2.3.3 COM Port (COM2/ COM3/ COM4) .....	35
2.3.4 Power Button .....	36
2.3.5 SMA Antenna Opening .....	37
2.4 CMOS Reset Button .....	38
2.5 Reserved Port Opening Panel .....	39
2.6 POC-900 Series Internal I/O .....	40
2.6.1 SO-DIMM Memory Socket .....	40
2.6.2 M.2 2280 M Key .....	41
2.6.3 Mini-PCIe Slot .....	43
2.7 MeziO® Interface .....	45
2.7.1 MeziO® Interface Pin Definition .....	46
2.7.2 MeziO® Modules for POC-900 Series .....	47

<b>3</b>	<b>System Installation</b>	
<b>3.1</b>	<b>Disassembling the System Enclosure</b>	<b>49</b>
<b>3.2</b>	<b>Installing Internal Components</b>	<b>51</b>
3.2.1	SO-DIMM Installation	51
3.2.2	M.2 2280 M Key Module Installation	56
3.2.3	mini-PCIe Module Installation	58
3.2.4	MezIO® Module Installation	60
<b>3.3</b>	<b>Installing the System Enclosure</b>	<b>63</b>
<b>3.4</b>	<b>DIN Rail Installation</b>	<b>65</b>
<b>3.5</b>	<b>Wall Mount Installation (Optional Accessory)</b>	<b>67</b>
3.5.1	Standard Wall Mount (Optional Accessory)	67
3.5.2	Vertical Wall Mount (Optional Accessory)	69
<b>3.6</b>	<b>Powering On the System</b>	<b>70</b>
3.6.1	Powering On Using the Power Button	70
3.6.2	Powering On Using An External Non-Latched Switch	71
3.6.3	Powering On Using Wake-on-LAN	72
<b>4</b>	<b>BIOS Settings</b>	
<b>4.1</b>	<b>COM1 Port Configuration</b>	<b>75</b>
4.1.1	COM Port High Speed Mode	76
4.1.2	COM Port Slew Rate	77
<b>4.2</b>	<b>COM2/ 3/ 4 Port Configuration</b>	<b>78</b>
<b>4.3</b>	<b>TPM Availability</b>	<b>79</b>
<b>4.4</b>	<b>Power over Ethernet</b>	<b>80</b>
<b>4.5</b>	<b>Wake-on-LAN</b>	<b>81</b>
<b>4.6</b>	<b>Power On after Power Failure</b>	<b>82</b>
<b>4.7</b>	<b>Boot Menu</b>	<b>83</b>
<b>4.8</b>	<b>Position New Boot Device</b>	<b>85</b>
<b>4.9</b>	<b>Watchdog Timer</b>	<b>86</b>
<b>5</b>	<b>OS Support and Driver Installation</b>	
<b>5.1</b>	<b>Operating System Compatibility</b>	<b>87</b>
<b>5.2</b>	<b>Driver Installation</b>	<b>88</b>
<b>5.3</b>	<b>Driver for Watchdog Timer and DIO</b>	<b>88</b>
<b>Appendix A Using WDT &amp; DIO</b>		
	<b>WDT and DIO Library Installation</b>	<b>90</b>
	<b>WDT Function Reference</b>	<b>93</b>
	InitWDT	93
	SetWDT	93
	StartWDT	94
	ResetWDT	94
	StopWDT	94
	<b>DIO Functions</b>	<b>95</b>
	InitDIO	95
	DReadLine	95
	DReadPort	95
	DWriteLine	96
	DWritePort	96
	<b>Appendix B PoE On/ Off Control</b>	<b>97</b>
	<b>PoE On/ Off Control Function Reference</b>	<b>97</b>
	GetStatusPoEPort	97
	EnablePoEPort	98
	DisablePoEPort	99

# Legal Information

All Neosys Technology Inc. products shall be subject to the latest Standard Warranty Policy

Neosys Technology Inc. may modify, update or upgrade the software, firmware or any accompanying user documentation without any prior notice. Neosys Technology Inc. will provide access to these new software, firmware or documentation releases from download sections of our website or through our service partners.

Before installing any software, applications or components provided by a third party, customer should ensure that they are compatible and interoperable with Neosys Technology Inc. product by checking in advance with Neosys Technology Inc. Customer is solely responsible for ensuring the compatibility and interoperability of the third party's products. Customer is further solely responsible for ensuring its systems, software, and data are adequately backed up as a precaution against possible failures, alternation, or loss.

For questions in regards to hardware/ software compatibility, customers should contact Neosys Technology Inc. sales representative or technical support.

To the extent permitted by applicable laws, Neosys Technology Inc. shall NOT be responsible for any interoperability or compatibility issues that may arise when (1) products, software, or options not certified and supported; (2) configurations not certified and supported are used; (3) parts intended for one system is installed in another system of different make or model.

# Contact Information

For our contact information, please visit our [official website](#).

## Declaration of Conformity

### FCC

This equipment has been tested and found to comply with the limits for a Class A digital device, pursuant to part 15 of the FCC Rules. These limits are designed to provide reasonable protection against harmful interference when the equipment is operated in a commercial environment. This equipment generates, uses, and can radiate radio frequency energy and, if not installed and used in accordance with the instruction manual, may cause harmful interference to radio communications. Operation of this equipment in a residential area is likely to cause harmful interference in which case the user will be required to correct the interference at own expense.

---

### CE

The product(s) described in this manual complies with all applicable European Union (CE) directives if it has a CE marking. For computer systems to remain CE compliant, only CE-compliant parts may be used. Maintaining CE compliance also requires proper cable and cabling techniques.

# Copyright Notice

All rights reserved. This publication may not be reproduced, transmitted, transcribed, stored in a retrieval system, or translated into any language or computer language, in any form or by any means, electronic, mechanical, magnetic, optical, chemical, manual or otherwise, without the prior written consent of Neosys Technology, Inc.

---

## **Disclaimer**

This manual is intended to be used as an informative guide only and is subject to change without prior notice. It does not represent commitment from Neosys Technology Inc. Neosys Technology Inc. shall not be liable for any direct, indirect, special, incidental, or consequential damages arising from the use of the product or documentation, nor for any infringement on third party rights.

---

## **Patents and Trademarks**

Neosys, the Neosys logo, Expansion Cassette, MezIO® are registered patents and trademarks of Neosys Technology, Inc.

Windows is a registered trademark of Microsoft Corporation.

Intel®, Core™ are registered trademarks of Intel Corporation

NVIDIA®, GeForce® are registered trademarks of NVIDIA Corporation

All other names, brands, products or services are trademarks or registered trademarks of their respective owners.

# Safety Precautions

- Read these instructions carefully before you install, operate, or transport the system.
- Install the system or DIN rail associated with, at a sturdy location
- Install the power socket outlet near the system where it is easily accessible
- Secure each system module(s) using its retaining screws
- Place power cords and other connection cables away from foot traffic. Do not place items over power cords and make sure they do not rest against data cables
- Shutdown, disconnect all cables from the system and ground yourself before touching internal modules
- Ensure that the correct power range is being used before powering the device
- Should a module fail, arrange for a replacement as soon as possible to minimize down-time
- By means of a power cord connected to a socket-outlet with earthing connection
- This product is intended to be supplied by a Listed Power Adapter or DC power source, rated 8V DC, 15A - 35V DC, 3.7A, Tma 70 degree C and 5000m altitude during operation. If further assistance is required, please contact Neousys Technology
- If the system is not going to be used for a long time, disconnect it from mains (power socket) to avoid transient over-voltage
- The unit is to be connected only to PoE networks without routing to the outside plant.

# Mesures de sécurité

- Lire attentivement ces directives avant d' installer, d' utiliser ou de transporter le système.
- Installer le système ou la barrette DIN qui lui est associée, à un endroit solide
- Installer la prise de courant près du système et pour qu' elle soit facilement accessible
- Fixer chaque module du système à l' aide de ses vis de fixation
- Éloigner de la circulation piétonne les cordons d' alimentation et autres câbles de connexion. Ne jamais placer d' objets sur les cordons d' alimentation et s' assurer qu' ils ne reposent pas contre les câbles de données
- Avant de toucher les modules internes, arrêter, débrancher tous les câbles du système et raccordez-vous à la terre
- S' assurer que la bonne plage de puissance est utilisée avant d' alimenter l' appareil
- Prévoir un remplacement dès que possible en cas de défaillance d' un module, afin de minimiser les temps d' arrêt
- Au moyen d' un cordon d' alimentation branché à une prise de courant avec mise à la terre (MALT)
- Ce produit doit être alimenté par un adaptateur de courant homologué ou une source d' alimentation CC, 8V DC, 15A - 35V DC, et 1.2 A, conçue pour fonctionner à 70 °C T<sub>ma</sub> et à 5000 m d' altitude. Communiquer avec Neousys Technology si de l' assistance supplémentaire est requise
- Si le système ne sera pas être utilisé pendant une période prolongée, le débrancher du réseau (prise de courant) pour éviter une surtension transitoire
- L'unité doit être connectée uniquement à des réseaux PoE sans routage vers l'installation extérieure.

## Service and Maintenance

- ONLY qualified personnel should service the system
- Shutdown the system, disconnect the power cord and all other connections before servicing the system
- When replacing/ installing additional components (expansion card, memory module, etc.), insert them as gently as possible while assuring proper connector engagement

## Avertissement concernant les piles

- Les piles risquent d'exploser si elles sont mal installées.
- Ne jamais essayer de recharger, d'ouvrir de force ou de chauffer les piles.
- Remplacer les piles uniquement avec le même type ou l' équivalent recommandé par le fabricant.

## Hot Surface Warning

 <p><i>HOT SURFACE. DO NOT TOUCH.</i> "ATTENTION: Surface chaude. Ne pas toucher."</p>	<p>WARNING!</p> <p>Components/ parts inside the equipment may be hot to touch! Please wait one-half hour after switching off before handling parts.</p>
---	---

## Surface chaude

**AVERTISSEMENT** : SURFACE CHAUDE. NE PAS TOUCHER.

Les composants et pièces à l'intérieur de l'équipement peuvent être chauds au toucher. Après l'arrêt, attendre au moins 30 minutes pour que le système refroidisse avant d'effectuer l'entretien.

- Respecter les règles de sécurité et d'entretien mentionnées au début du guide d'utilisation!

## Battery Warning

**Caution!**



- Batteries are at risk of exploding if incorrectly installed
- Do not attempt to recharge, force open, or heat the battery
- Replace the battery only with the same or equivalent type recommended by the manufacturer

## Entretien et réparation

- La réparation du système ne peut être effectuée que par du personnel qualifié
- Avant de réparer le système, arrêter le système, débrancher le cordon d'alimentation et toutes les autres connexions
- Lors du remplacement ou de l'installation de composants supplémentaires (carte d'extension, module de mémoire, etc.), les insérer le plus doucement possible tout en s'assurant que les connecteurs sont bien engagés jusqu'au bout

## ESD Precautions

- Handle add-on module, motherboard by their retention screws or the module's frame/ heat sink. Avoid touching the PCB circuit board or add-on module connector pins
- Use a grounded wrist strap and an anti-static work pad to discharge static electricity when installing or maintaining the system
- Avoid dust, debris, carpets, plastic, vinyl and styrofoam in your work area.
- Do not remove any module or component from its anti-static bag before installation

## Précautions nécessaires de décharge électrostatique (ESD)

- Tenir le module complémentaire et la carte mère par leurs vis de rétention ou le châssis/dissipateur de chaleur du module. Éviter de toucher la carte de circuit imprimé ou les broches du connecteur du module complémentaire
- Afin de décharger l'électricité statique, utiliser une dragonne mise à la terre et un tapis de travail antistatique lors de l'installation ou de l'entretien du système
- Éviter la poussière, les débris, les tapis, le plastique, le vinyle et la mousse de polystyrène dans votre zone de travail.
- Ne retirer aucun module ou composant de son sac antistatique avant l'installation

# Restricted Access Location

The controller is intended for installation only in certain environments where both of the following conditions apply:

- Access can only be gained by QUALIFIED SERVICE PERSONNEL who have been instructed on the reasons for restrictions applied to the location and any precautions that shall be taken
- Access is through the use of a TOOL, lock and key, or other means of security, and is controlled by the authority responsible for the location

# Lieu d'accès restreint

Le contrôleur doit être installé uniquement dans les environnements où les deux conditions suivantes sont présentes :

- Le lieu ne peut être accédé que par du PERSONNEL TECHNIQUE QUALIFIÉ informé des raisons des restrictions appliquées à l'emplacement et des précautions à prendre
- L'accès est contrôlé par l'autorité responsable de l'emplacement et se fait au moyen d'un OUTIL, d'une serrure et d'une clé ou d'autres moyens de sécurité

---

# About This Manual

This manual introduces and demonstrates installation procedures of Neosys POC-900 series systems.

## Revision History

Version	Date	Description
1.0	Jan. 2026	Initial release
1.1	Mar. 2026	Updated disclaimer, warning, and mounting specifications
1.2	Mar. 2026	Updated memory module installation procedure

# 1 Introduction

The POC-900 series is the latest addition to Neosys' compact POC family, powered by the AMD® Ryzen™ embedded 8000 series platform. By retaining the same footprint, dimensions and DIN-rail mounting design as the current POC-700 and POC-500 series, the POC-900 ensures compatibility with existing installations while offering significant performance and connectivity upgrades.

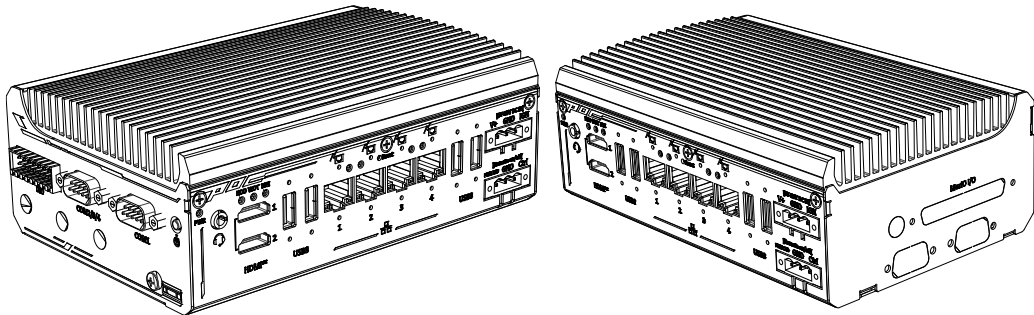

Featuring the AMD® Ryzen™ PRO 8640U processor, POC-900 offers up to 270% performance improvement over POC-500 platforms. In addition, its storage and memory have been enhanced, with support for M2 Gen 4x4 NVMe SSD and DDR5-5600 memory, they enable faster data access and improved system responsiveness for demanding edge AI and industrial applications.

The POC-900 provides four Gigabit Ethernet ports with PoE+, four USB 3.2 ports, and four digital inputs and outputs (DI/ DO) for connectivity with cameras, sensors, and control systems. In addition, it supports Neosys' MezIO® interface, allowing flexible I/O expansion to meet specific application requirements. Combining next-generation AMD® performance with compact, rugged reliability, the POC-900 is engineered to deliver exceptional computing power and versatility for industrial automation, edge AI, and machine vision deployments.

## 1.1 Specification of POC-915

<b>System Core</b>	
Processor	AMD® Ryzen™ PRO 8640U CPU (6C/ 12T, 3.5/ 4.9 GHz, 15W-30W TDP)
Graphics	AMD® Radeon RDNA3 Graphics
Memory	Up to 32GB DDR5-5600 SDRAM (one SODIMM socket)
TPM	Supports dTPM 2.0
<b>Panel I/O Interface</b>	
Ethernet	4x Gb Ethernet ports by Intel® I350-AM4 (with WoL)
PoE+	IEEE 802.3at PoE+ on port #1~ 4 <ul style="list-style-type: none"> <li>· 32W power budget (with UL certified)</li> <li>· 100W power budget (maximum)</li> </ul>
Native Video Port	2x HDMI™ 2.0b, supporting 3840 x 2160 @ 60Hz
Serial Port	1x software-programmable RS-232/422/485 ports (COM1) 3x 3-wire RS-232 ports (COM2/3/4) or 1x RS-422/485 port (COM2)
USB	4x USB 3.2 Gen2x1 (10 Gbps) ports in type-A connectors with screw-lock
Audio	1x 3.5 mm jack for mic-in and speaker-out
<b>Storage Interface</b>	
M.2 M key	1x M.2 2280 M key socket (PCIe Gen4 x4) for NVMe SSD
<b>Expandable I/O</b>	
Mini-PCIe	1x full-size mini PCI Express socket (PCIe + USB2) with internal micro SIM socket
Expandable I/O	1x MezIO® expansion port for Neosys MezIO® modules
<b>Power Supply</b>	
DC Input	1x 3-pin pluggable terminal block for 8-35V DC input
Remote Ctrl & LED Output	1x 3-pin pluggable terminal block for remote control and PWR LED output
<b>Mechanical</b>	
Dimension	64 mm (W) x 116 mm (D) x 176 mm (H) 92 mm (W) x 116 mm (D) x 176 mm (H) with fan
Weight	1.2 kg or 1.4 kg (with fan)
Mounting	DIN-rail mount (standard) or Wall-mount (optional)
<b>Environmental</b>	

Operating Temperature	-25°C ~ 70°C (15W TDP, fanless) -25°C ~ 70°C (30W TDP, with fan)
Storage Temperature	-40°C to 85°C
Humidity	10% to 90% , non-condensing
Vibration	MIL-STD-810H, Method 514.8, Category 4 (with wall-mount)
Shock	MIL-STD-810H, Method 516.8, Procedure I (with wall-mount)
EMC	CE/FCC Class A, according to EN 55032 & EN 55035
Safety	UL 62368-1, IEC 62368-1

## 1.2 Dimension

### 1.2.1 Superior View

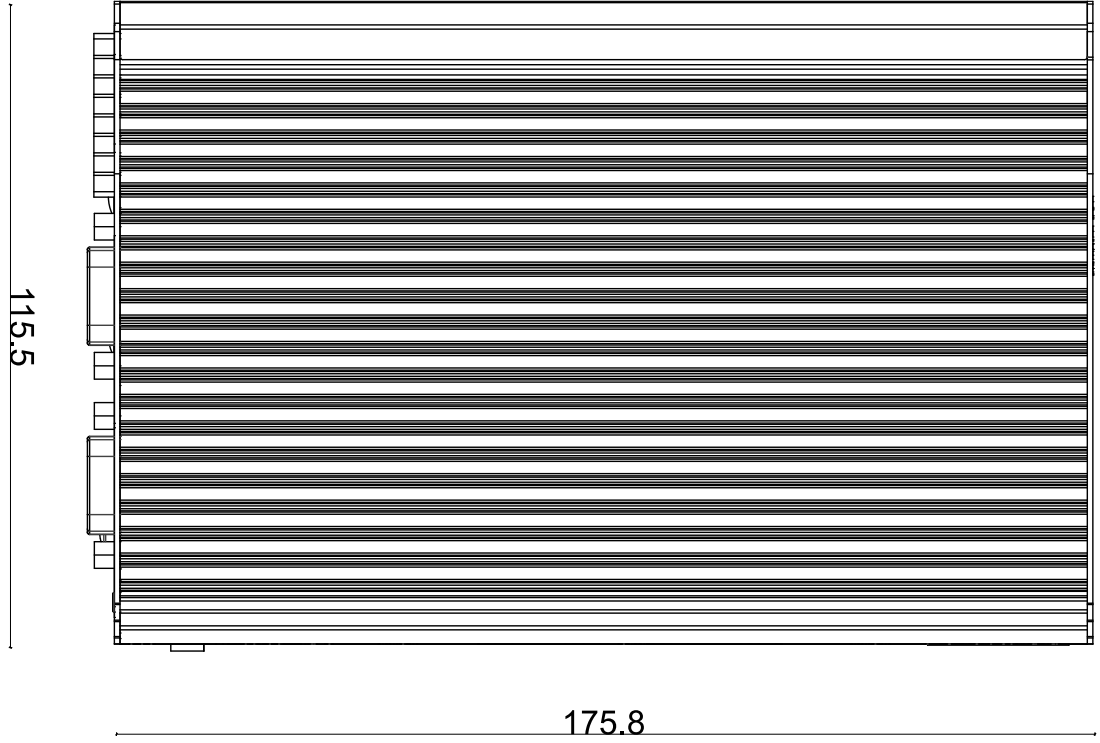

### 1.2.2 Front Panel View

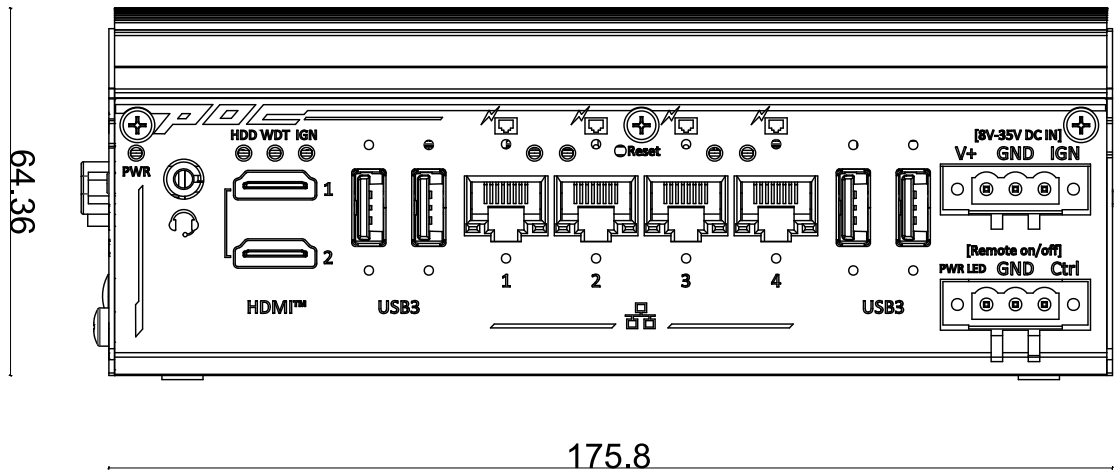

### 1.2.3 COM Port Panel View

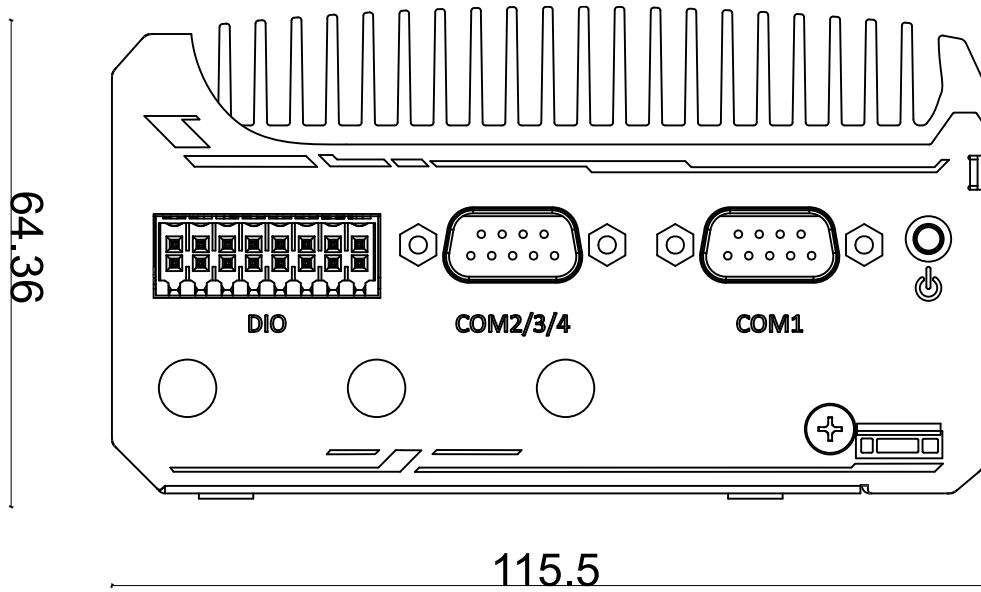

### 1.2.4 Bottom View

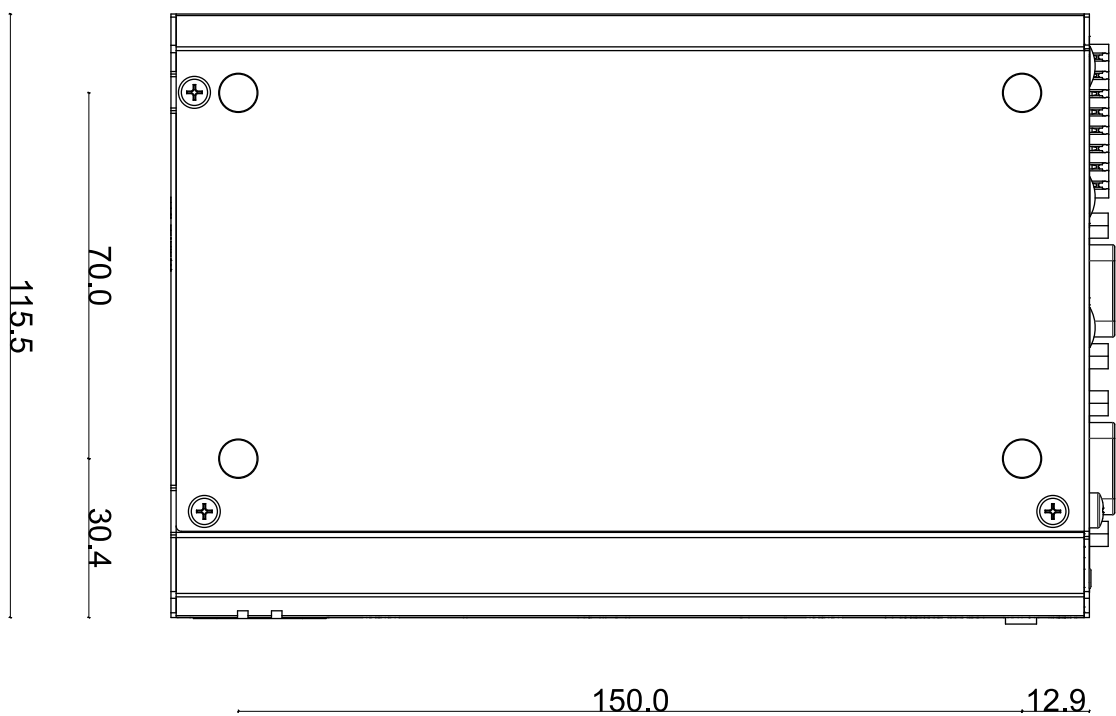

## 1.3 POC-900 Series Mounting Options

The system comes with various mounting options such as DIN-rail and wall-mount bracket. DIN-rail mount clip is shipped with POC-900 series as standard mounting option, and an optional wall mount (purchased separately).

### 1.3.1 DIN-Rail Mount Clip

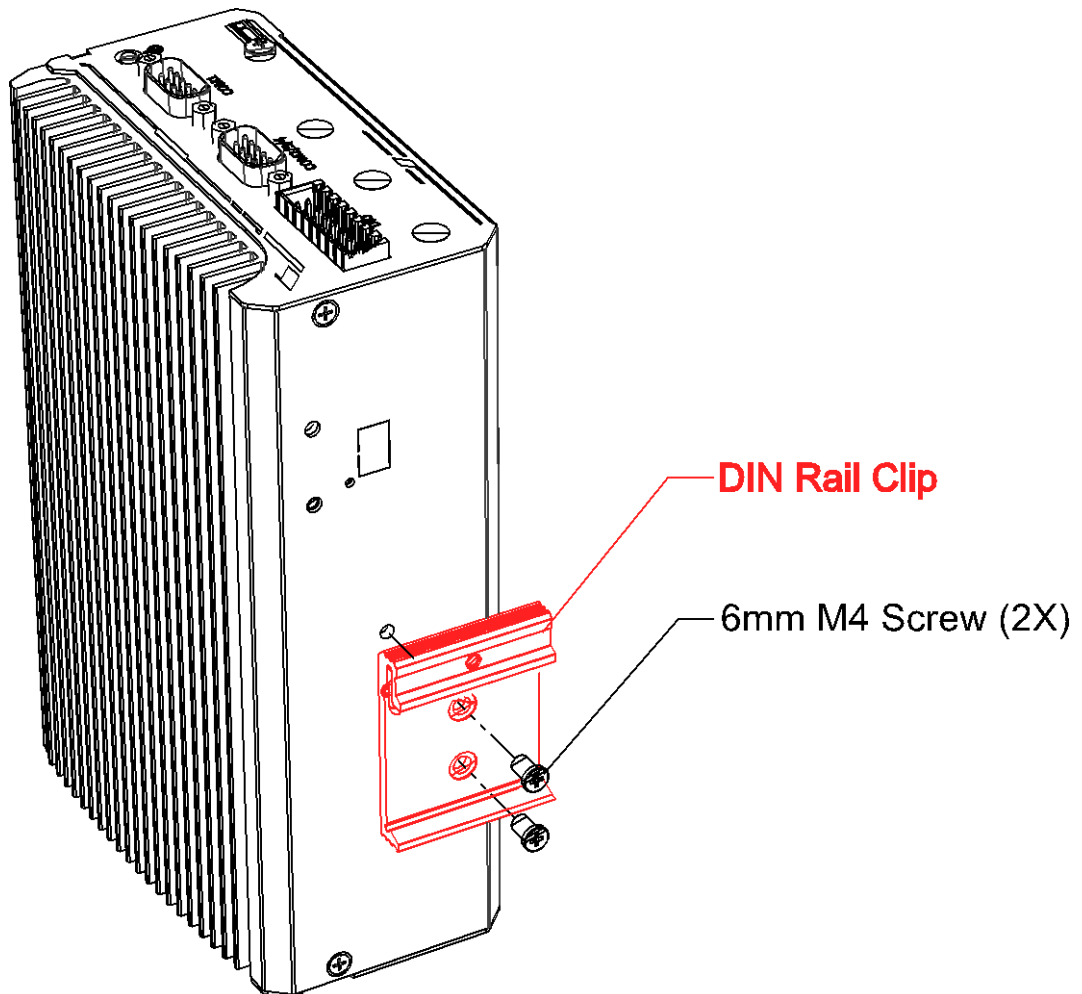

### 1.3.2 Wall Mount (Optional)

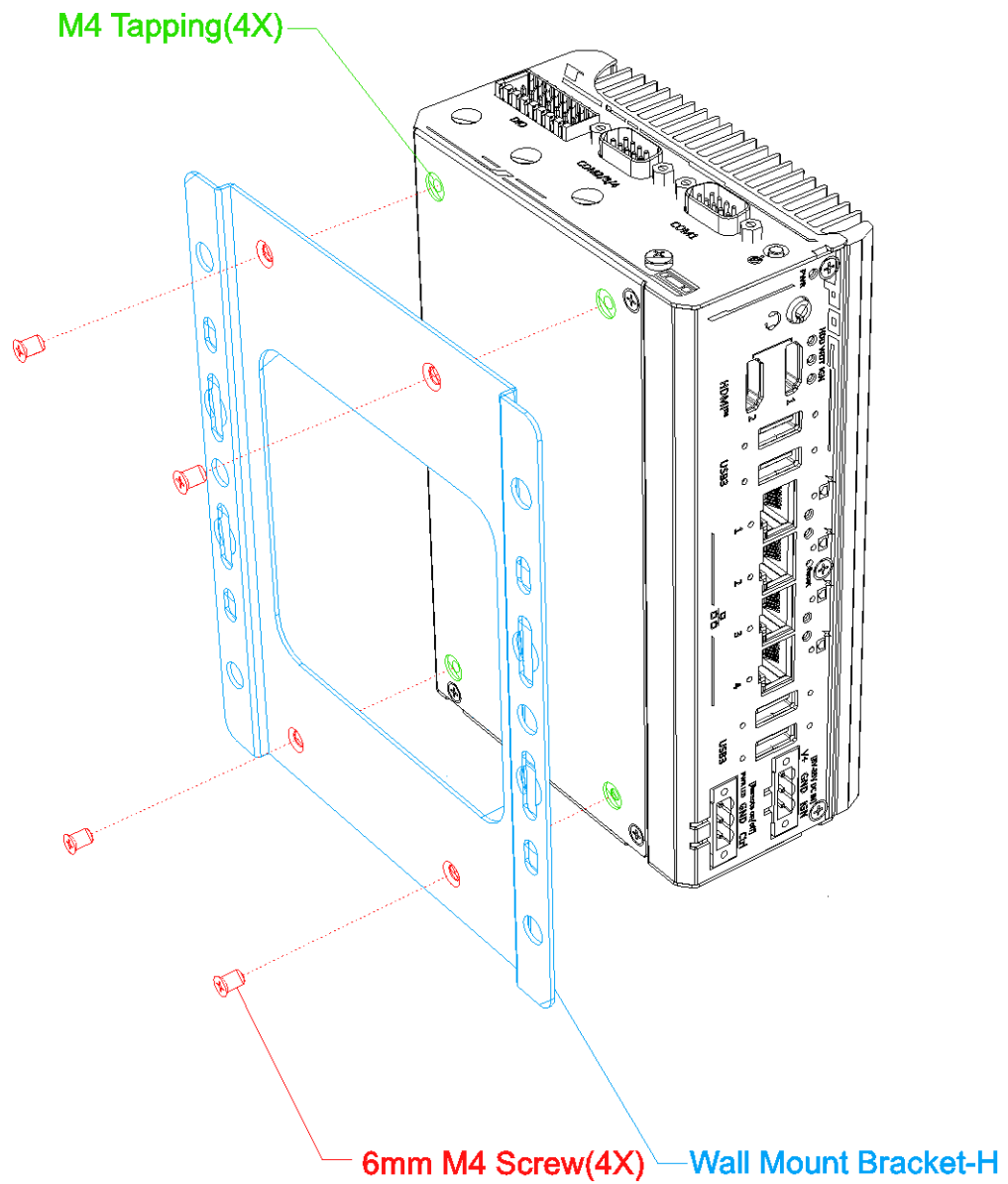

### 1.3.3 Vertical Wall Mount (Optional)

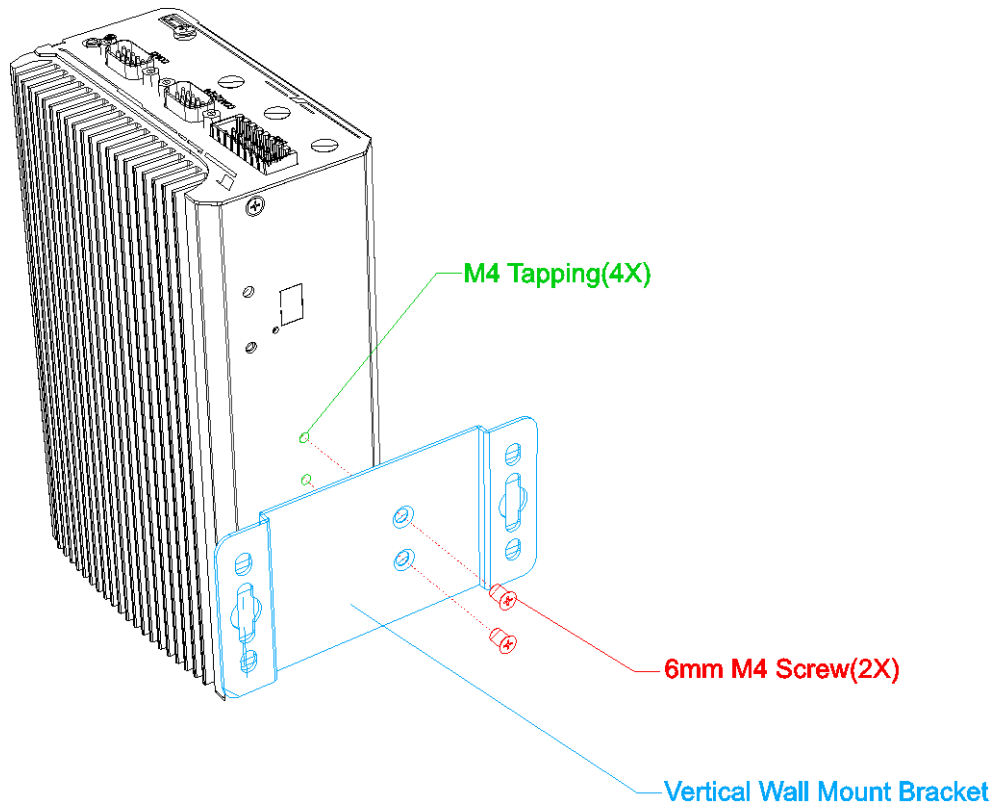

## 2 System Overview

Upon receiving and unpacking your POC-900 series, please check immediately if the package contains all the items listed in the following table. If any item(s) are missing or damaged, please contact your local dealer or Neosys Technology.

### 2.1 Unpacking the System

Item	Description	Qty
1	POC-900 ultra-compact fanless computer (Please verify additionally purchased accessories such as memory module, M.2 SSD, MezIO®, etc.)	1
2	3-pin pluggable terminal block	2
3	16-pin DIO terminal block	1
4	DIN-Rail Mount Clip	1
5	Screw package	1

## 2.2 POC-900 Series Front Panel

The front panel of POC-900 series features rich I/O ports, it has dual HDMI™ output, four USB3.2 Gen2x1, four GbE PoE+, CMOS reset button and 3-pin terminal block for DC input and 3-pin remote on/ off control.

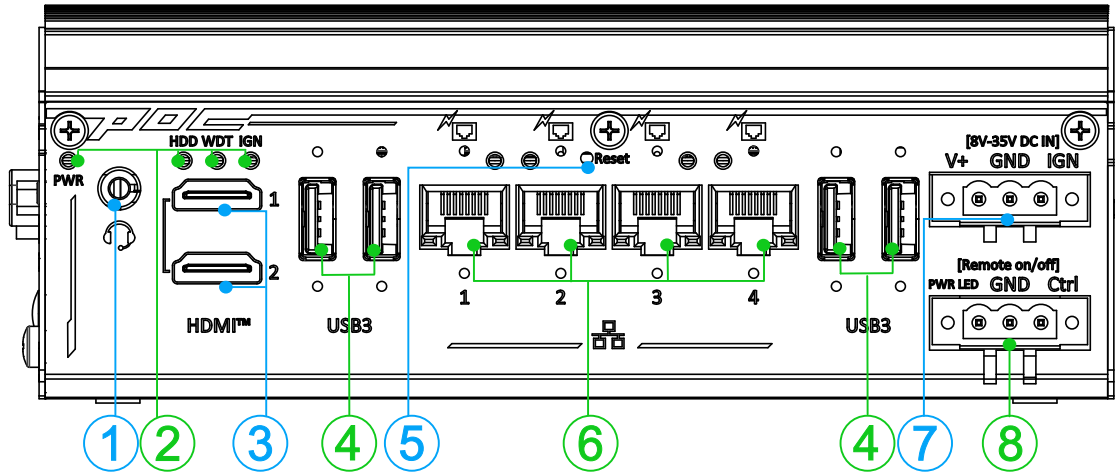

No.	Item	Description
1	<a href="#">3.5mm microphone-in/ speaker-out jack</a>	3.5mm jack for speaker-out or microphone-input.
2	<a href="#">System status LED</a>	Four system LEDs, Power (PWR), Hard Disk Drive (HDD), Watchdog Timer (WDT) and Ignition control (IGN).
3	<a href="#">HDMI™ Port</a>	The HDMI™ 2.0b ports are high-resolution graphics/ data port supporting up to 3840 x 2160 @ 60Hz.
4	<a href="#">USB 3.2 Gen 2x1 port</a>	The USB 3.2 Gen2x1 ports support up to 10Gbit/s data transfer bandwidth and are backward compatible with USB 2.0/ 1.1/ 1.0.
5	<a href="#">Reset button</a>	Use this button to manually reset the system.
6	<a href="#">GbE PoE+ port</a>	The Ethernet port offers up to 1Gb/s transfer bandwidth and are PoE+ capable, supplying both data and electric power to PoE certified devices.
7	<a href="#">3-pin terminal block (DC/ ignition input)</a>	Compatible with DC power input from 8V - 35V. When MeziO®-V21 module is installed, it can also be used for ignition signal input.
8	<a href="#">3-Pin Remote On/ Off</a>	Allows for external switch extension when the system is placed inside a cabinet.

### 2.2.1 3.5mm Microphone-In/ Speaker-Out Jack

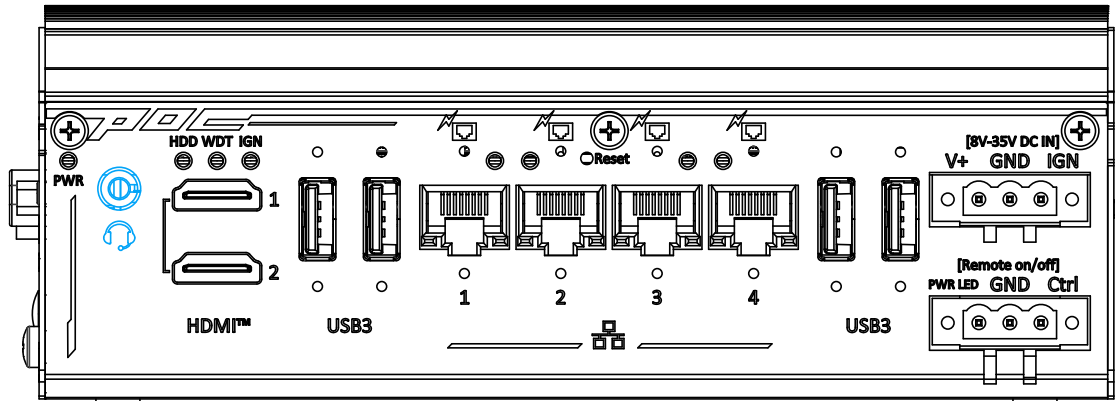

There is a single 3.5mm audio jack on the top panel. The port is used for microphone input as well as speaker output.

### 2.2.2 System Status LED

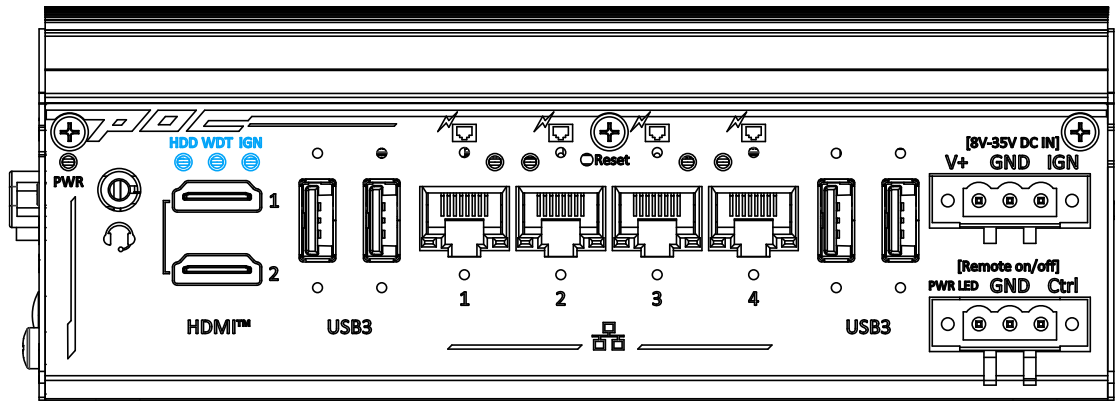

There are three LED indicators on the front panel: HDD, WDT and IGN. The descriptions of these three LEDs are listed in the following table.

Indicator	Color	Description
PWR	Green	Power indicator, lit when system is on.
HDD	Red	Hard drive indicator, flashing when HDD is active
WDT	Yellow	Watchdog timer indicator, flashing when watchdog timer has started
IGN	Yellow	If ignition option (MezIO®-V21) is applied, this LED is used to indicate ignition signal status (lit when IGN signal is applied).

### 2.2.3 HDMI™ Port

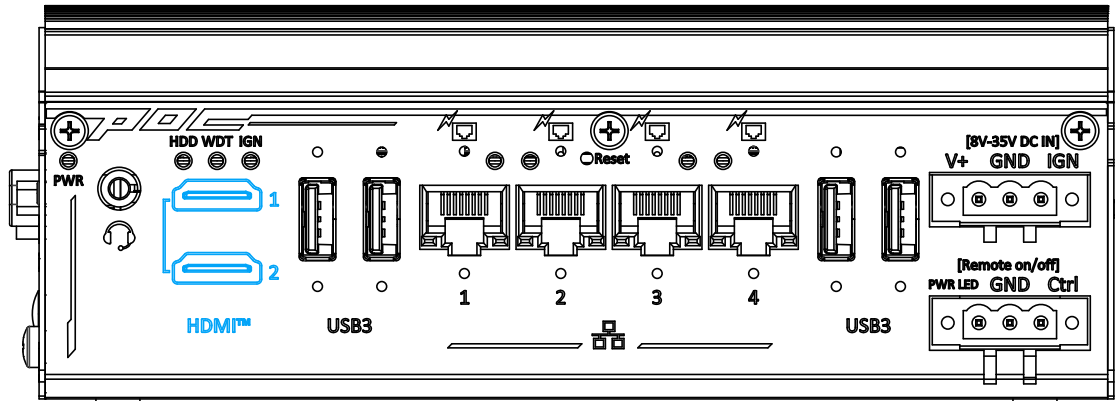

The High-Definition Multimedia Interface (HDMI) port provides uncompressed high-quality digital video and audio transmission between the system and a multimedia display device on a single cable. You can connect to other digital inputs by using a HDMI-to-DVI or HDMI-to-DP cable.



**HDMI-to-DP**

The system supports dual independent display outputs by connecting display devices DisplayPort connections. To support dual display outputs and achieve best DisplayPort output resolution in Windows, you need to install corresponding graphics drivers. Please refer to section [OS Support and Driver Installation](#) for details.

### 2.2.4 USB3.2 Gen2x1 Port

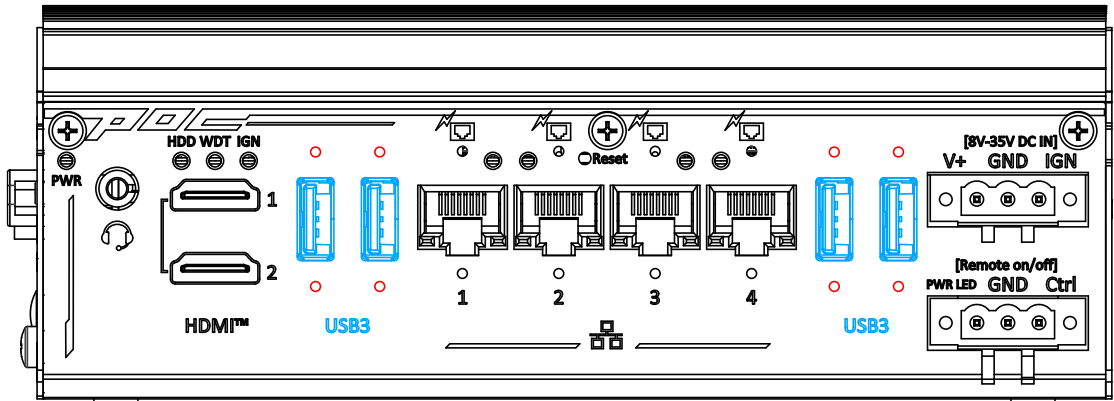

The system offers four USB 3.2 Gen2x1 (SuperSpeed USB) ports on its front panel. They are implemented by native xHCI (eXtensible Host Controller Interface) controller and are backward compatible with USB 2.0, USB 1.1 and USB 1.0 devices. UEFI USB support is also provided so you can use USB keyboard/mouse in UEFI shell environment. Indicated in **red** are screw-lock holes for each USB port.

### 2.2.5 Reset Button

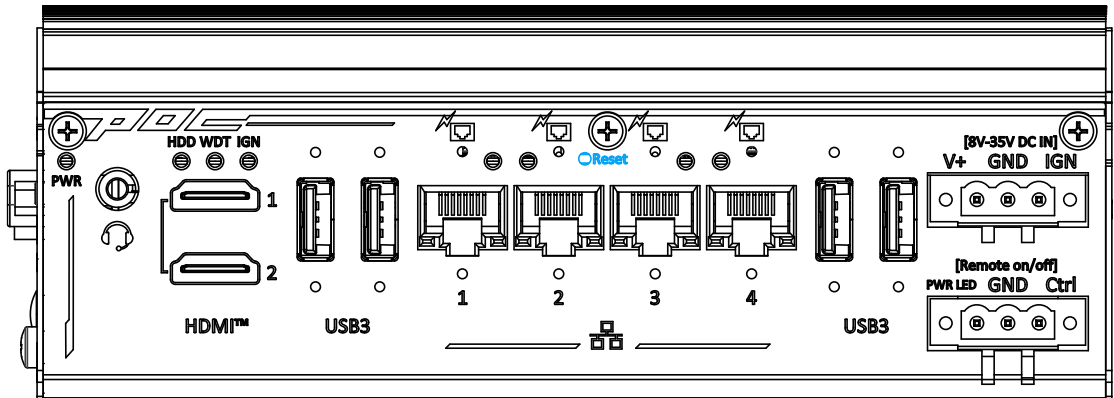

The reset button is used to manually reset the system in case of system halt or malfunction. To avoid unexpected reset, the button is purposely placed behind the panel. To reset, please use a pin-like object (eg. tip of a pen) to access the reset button.

## 2.2.6 GbE PoE+ Port

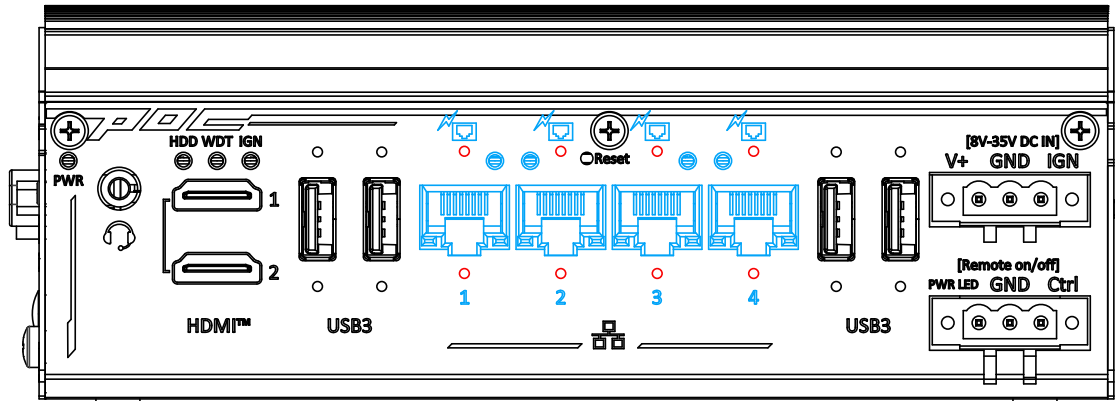

The system offers four GbE PoE+ ports using Intel® I350-AM4 controller. When plugged in and connected via the Ethernet cable, the LEDs on the RJ45 connector indicate connection status and speed. Indicated in **red** are screw-lock holes for each USB port.

The Power over Ethernet (PoE+) port supply both power and data on a standard CAT-5/ CAT-6 Ethernet cable. Acting as a PSE (Power Sourcing Equipment), compliant with IEEE 802.3at, each port delivers up to 25W to a Powered Device (PD), with a total of 100W maximum power budget. PoE automatically detects and determine if the connected device is PoE PD or not before supplying power, making it compatible with standard Ethernet devices as well.

### Active/Link LED (Right)

LED Color	Status	Description
Yellow	Off	Ethernet port is disconnected
	On	Ethernet port is connected and no data transmission
	Flashing	Ethernet port is connected and data is transmitting/receiving

### Speed LED (Left)

LED Color	Status	Description
Off, Green or Orange	Off	10 Mbps
	Green	100 Mbps
	Orange	1000 Mbps

### 2.2.7 3-Pin Terminal Block

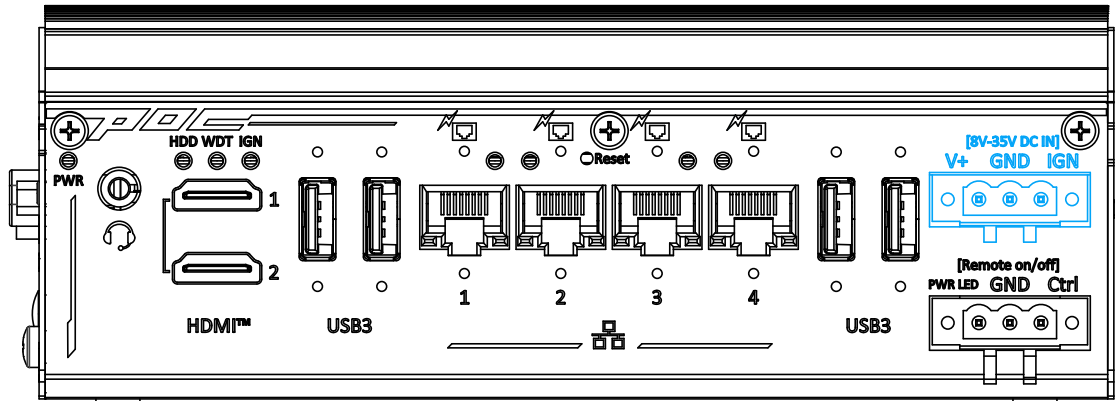

The system accepts a wide range of DC power input from 8 to 35V via a 3-pin pluggable terminal block, which is fit for field usage where DC power is usually provided. The screw clamping mechanism on the terminal block offers connection reliability when wiring DC power.

In addition to DC power input, this terminal block can also accept an optional ignition signal input (IGN) when you have MezIO® module with IGN function installed.

**NOTE**  
 Please make sure the voltage of DC power is correct before you connect it to the system. Supplying a voltage over 35V will damage the system.

### 2.2.8 3-Pin Remote On/ Off

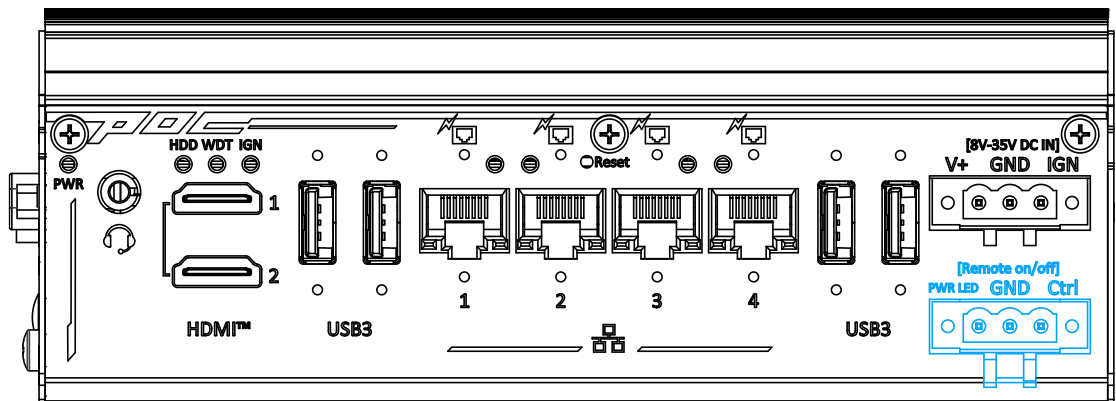

The “Remote On/ Off” 3-pin connection allows for external switch extension. It is useful when the system is placed in a cabinet or a not easily accessed location. You may connect an external remote with an external status LED indicator (15mA) by connecting to PWR LED and GND.

## 2.3 POC-900 Series COM Port Panel

The COM port panel of POC-900 series features additional I/O functions, such as digital I/O, COM ports and antenna opening for antenna installation.

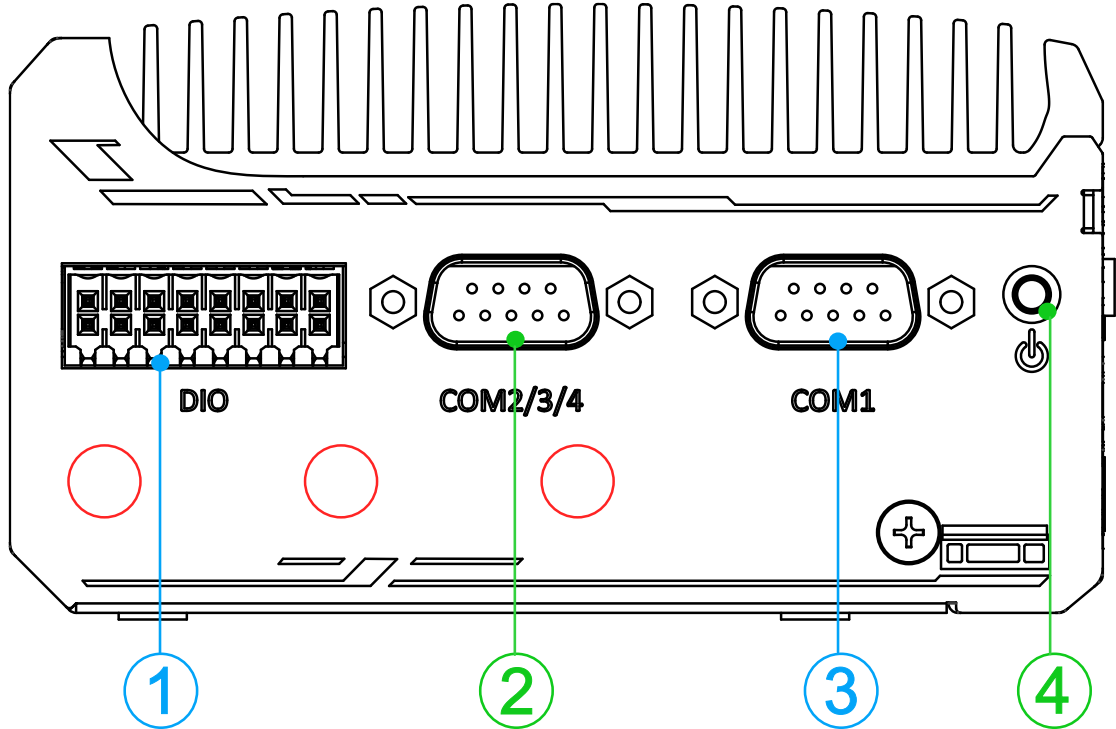

No.	Item	Description
1	Digital I/O	4 channel isolated digital input 4 channel isolated digital output
2	COM port 2/ 3/ 4	<b>Can be configured as:</b> <b>COM2:</b> single RS-422/ 485 port <b>COM2/ COM3/ COM4:</b> three 3-wire RS-232 ports
3	COM port 1	Software programmable RS-232/ 422/ 485 port.
4	Power button	Use this button to turn on or shutdown the system.
		Opening reserved for SMA antenna installation.

### 2.3.1 Digital Input/ Output

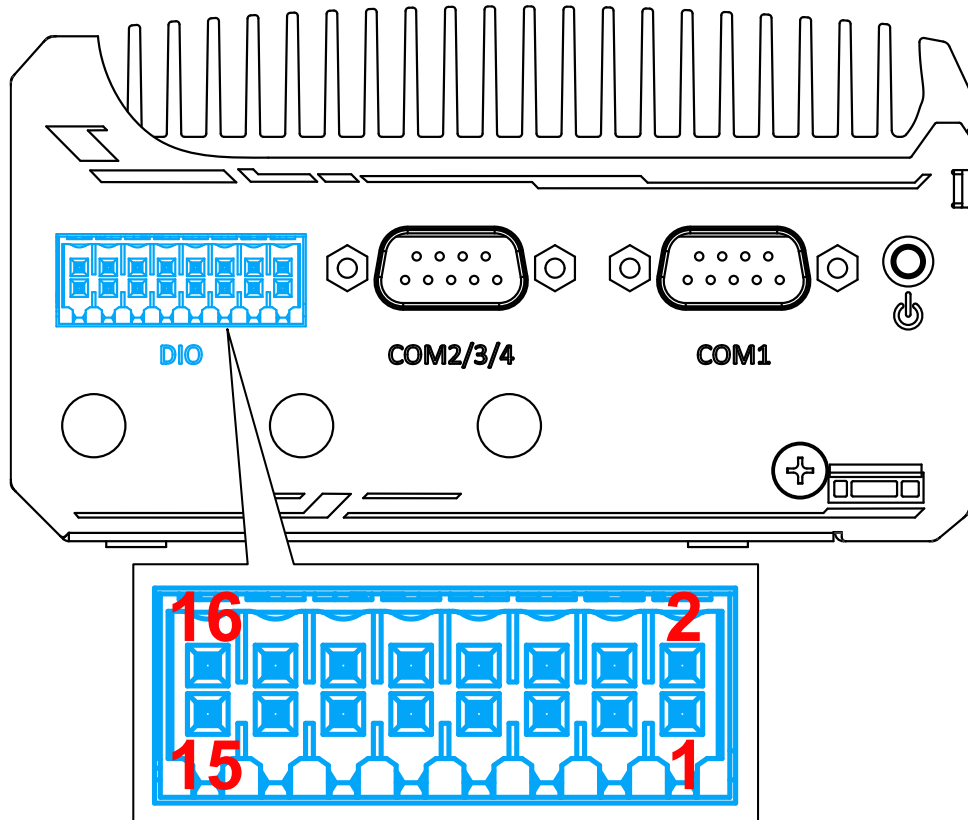

The system provides 4x isolated digital input channels and 4x isolated digital output channels. The DIO functions support polling mode I/O access and DI change-of-state interrupt. Please refer to [Watchdog Timer & Isolated DIO](#) for information on wiring and programming the isolated DIO channels.

Pin#	Pin Definition	Pin#	Pin Definition
1	ISO_DI0_CN	9	ISO_DO0_CN
2	IGND0	10	EOGND
3	ISO_DI1_CN	11	ISO_DO1_CN
4	IGND1	12	EOGND
5	ISO_DI2_CN	13	ISO_DO2_CN
6	IGND2	14	EOGND
7	ISO_DI3_CN	15	ISO_DO3_CN
8	IGND3	16	VDD

\*When using DO0 ~ DO3, DOGND is the ground should be used.

### Wiring for Digital Input

The digital input function is implemented using a photo-coupler with an internally series-connected 1kΩ resistor. You need to provide a voltage to specify the logic high/low state. The input voltage for logic high is 5~24V, and the input voltage for logic low is 0~1.5V.

<b>Channel</b>	4
<b>Type</b>	Sink mode
<b>Interface</b>	Unipolar Photocoupler
<b>Isolation Voltage</b>	2500Vrms
<b>Rated Input Voltage</b>	0V-24V
<b>Logic High Voltage</b>	5V-24V
<b>Logic Low Voltage</b>	0V-1.5V
<b>Operation Mode</b>	Polling
<b>Response Time (Rise)</b>	3us
<b>Response Time (Fall)</b>	3us

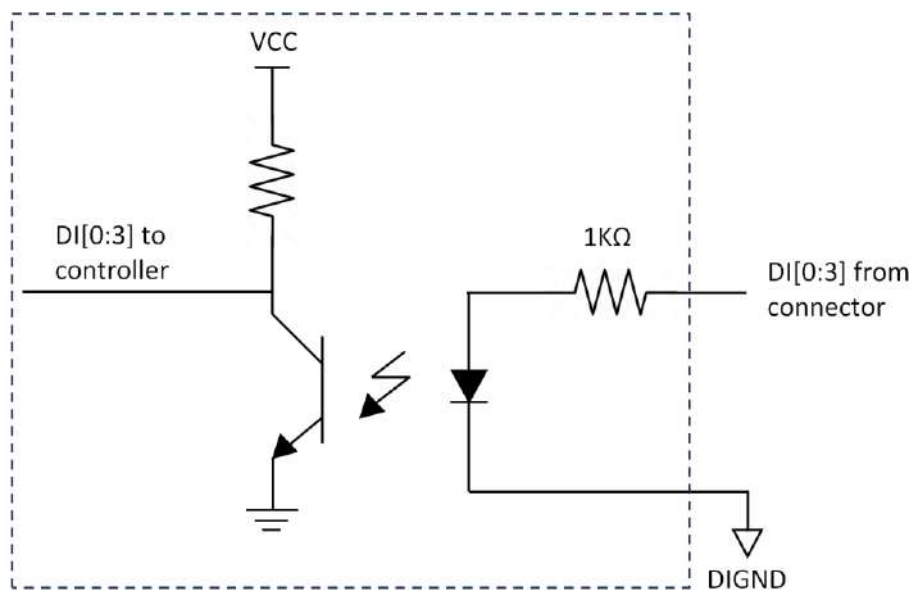

### Wiring for Digital Output

The digital output function is implemented using PhotoMOS. The DO channels are configured as NO (normally-open) configuration. When you turn on the system, all DO channels have a deterministic state of logic 0 (circuit disconnected from GND return). When logic 1 is specified, MOSFET is activated and GND return path is established. The digital output function on the system supports sinking current connection. The following diagrams are the suggested wiring for DO:

<b>Channel</b>	4
<b>Type</b>	Sink mode
<b>Interface</b>	Bidirectional PhotoMOS
<b>Isolation Voltage</b>	1500V AC
<b>Operation Voltage</b>	0V-24V
<b>Driving Current</b>	250mA
<b>Operation Mode</b>	Polling
<b>Response Time (Turn on)</b>	660us ~ 2ms
<b>Response Time (Turn off)</b>	90us ~ 210us

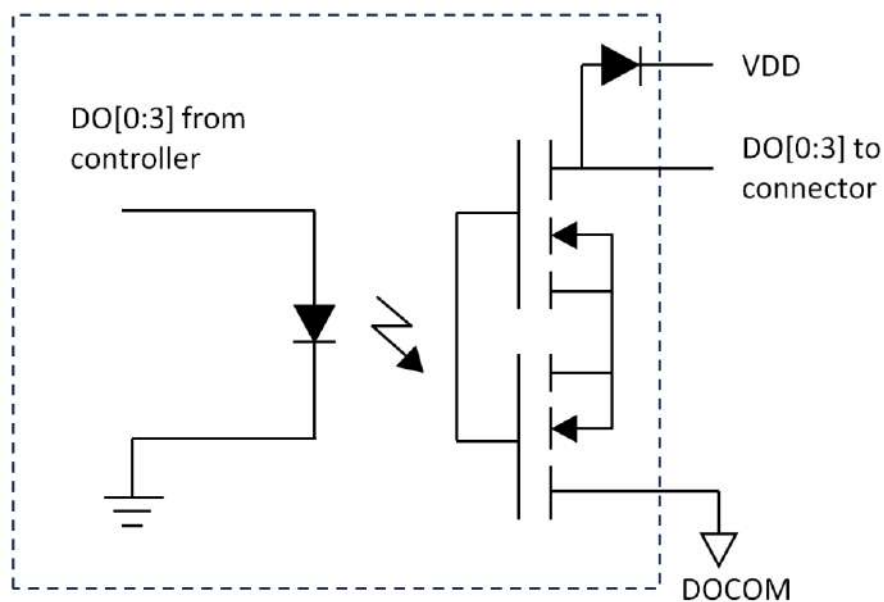

### 2.3.2 COM 1 Port

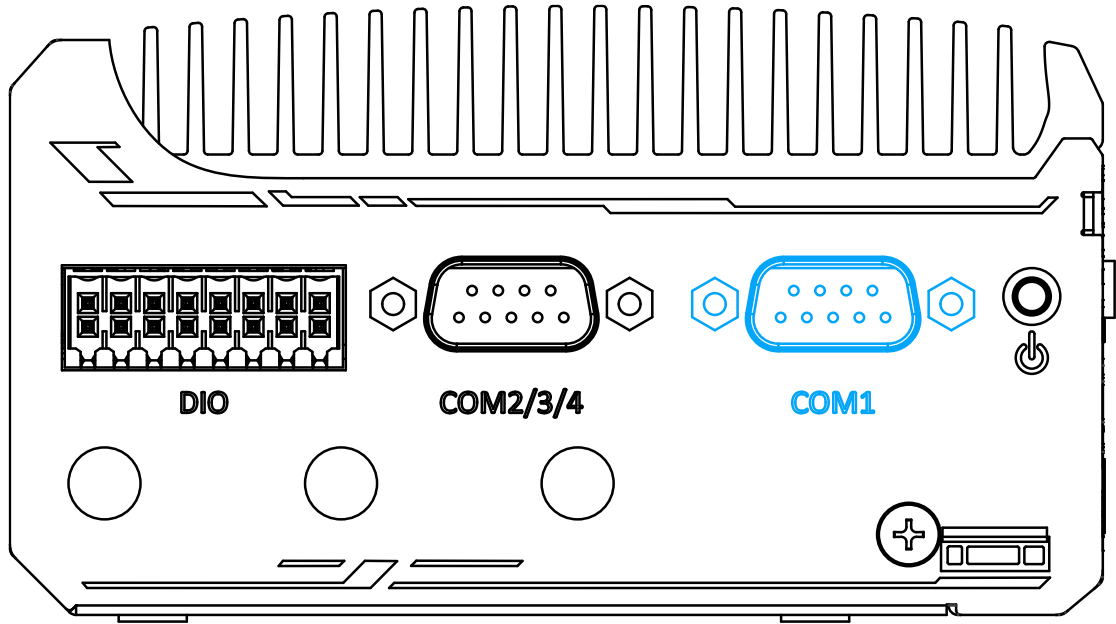

Implemented using industrial-grade ITE8786 Super IO chip (-40 to 85°C) and provide up to 921600 bps baud rate, COM1 is a software-configurable RS-232/422/485 port via 9-pin D-Sub male connector. The operation mode, slew rate and termination of COM1 can be set in BIOS setup utility. The following table describes the pin definition of COM ports.

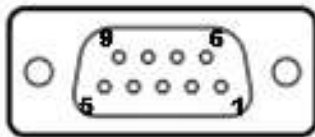

Pin#	COM1		
	RS-232 Mode	RS-422 Mode	RS-485 Mode (Two-wire 485)
1	DCD		
2	RX	422 TXD+	485 TXD+/RXD+
3	TX	422 RXD+	
4	DTR	422 RXD-	
5	GND	GND	GND
6	DSR		
7	RTS		
8	CTS	422 TXD-	485 TXD-/RXD-
9	RI		

### 2.3.3 COM Port (COM2/ COM3/ COM4)

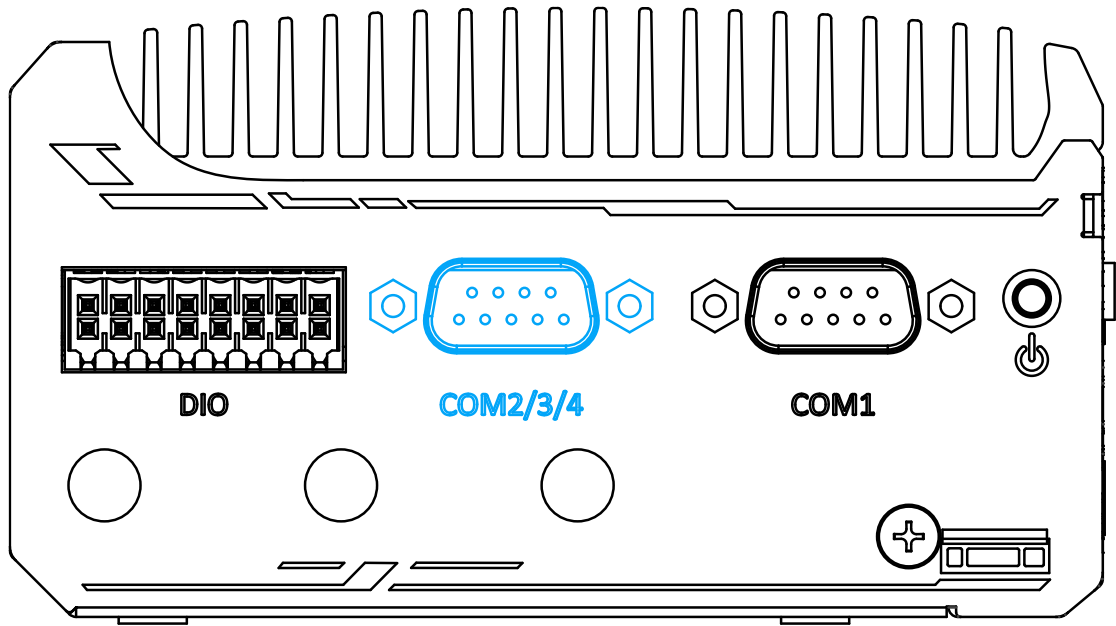

Implemented using industrial-grade ITE8786 Super IO chip (-40 to 85°C) and provide up to 921600 bps baud rate, the D-Sub male connector (COM2/ 3/ 4) can be configured in the BIOS as single RS-422/ 485 port (COM2) or three 3-wire RS-232 ports (COM2/COM3/COM4). Please refer to [COM2/ 3/ 4 Port Configuration](#) for configuring operation mode. An optional 1-to-3 Y-cable is available to connect three RS-232 devices.

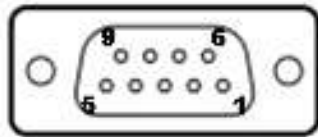

**COM2/ 3/ 4 Pin**



**1-to-3 Y-cable**

The following table describes the pin definition of the COM port

	3-port RS-232 COM2/ 3/ 4		
Pin#	COM2	COM3	COM4
1			
2	RX		
3	TX		
4		TX	
5	GND	GND	GND
6		RX	
7			TX
8			RX
9			

	Single port RS-422/ 485 COM2	
Pin#	RS-422	RS-485
1		
2	TxD+	TxD+/ RxD+
3	RxD+	
4	RxD-	
5	GND	GND
6		
7		
8	TxD-	TxD-/ RxD-
9		

### 2.3.4 Power Button

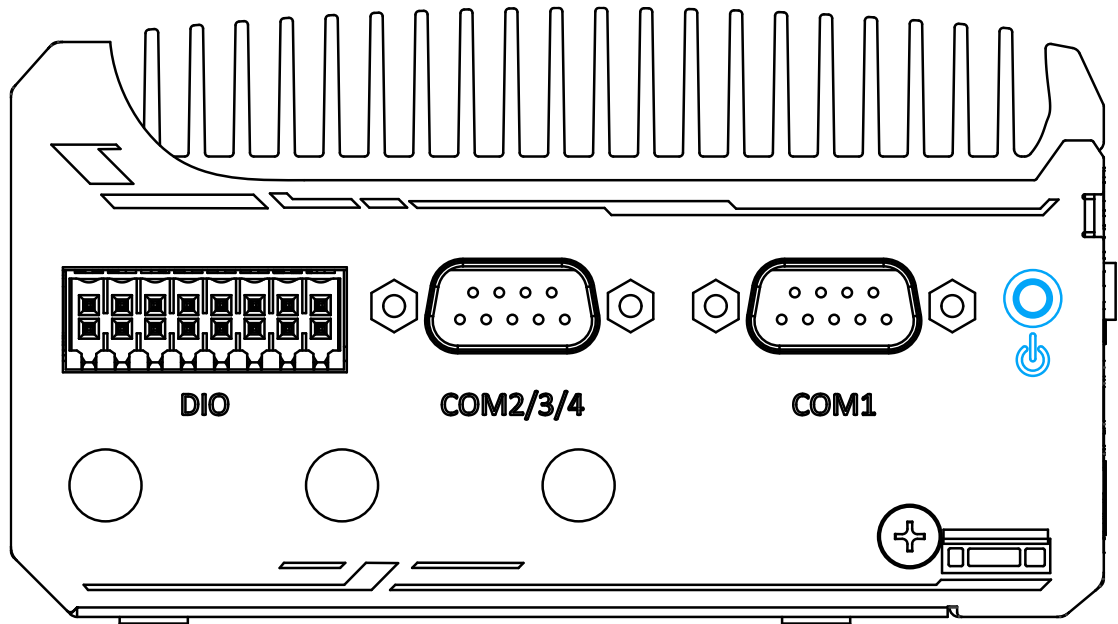

The power button is a non-latched switch for ATX mode on/off operation. Press to turn on the system, PWR LED should light up and to turn off, you can either issue a shutdown command in the OS, or just press the power button. In case of system halts, you can press and hold the power button for 5 seconds to force-shutdown the system. Please note that there is a 5 seconds interval between two on/off operations (i.e. once turning off the system, you will need to wait for 5 seconds to initiate another power-on operation).

### 2.3.5 SMA Antenna Opening

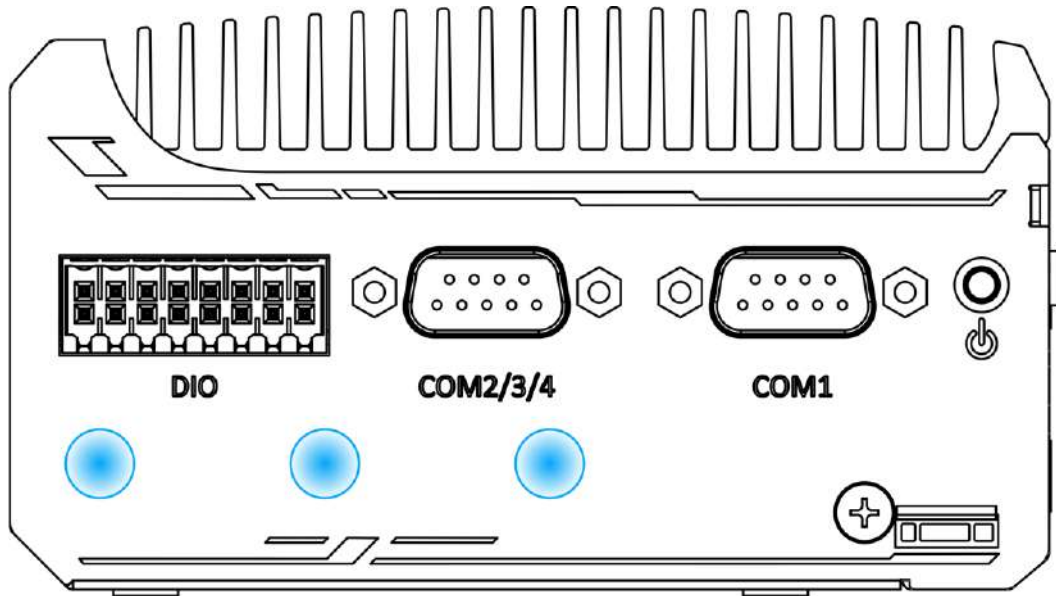

The system offers three SMA antenna openings reserved for SMA antenna installations. Users can take advantage of these three openings when installing mini-PCIe module for wireless communication reception such as 5G, 4G, GPS or WiFi.

## 2.4 CMOS Reset Button

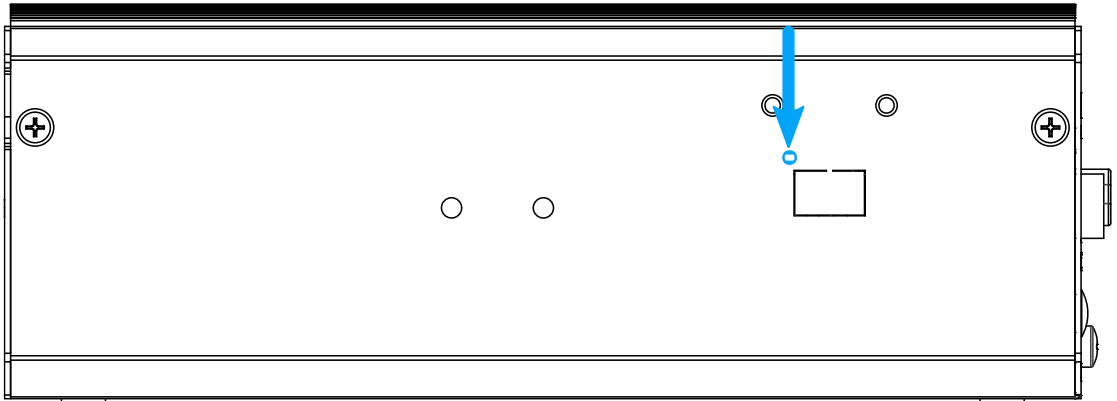

Positioned on the rear panel (opposite the IO panel), indicated by the **blue arrow**, the CMOS Reset button is used to manually reset the motherboard BIOS in case of system halt or malfunction. To avoid unexpected operation, it is purposely placed behind the panel. To reset, please use the tip of a pen, press and hold for at least 5 seconds to reset the BIOS.

## 2.5 Reserved Port Opening Panel

The reserved port opening panel has reserved openings for DIO or extra COM ports. Choose from a wide range Neousys' MeziO® modules and find one that best suit your needs.

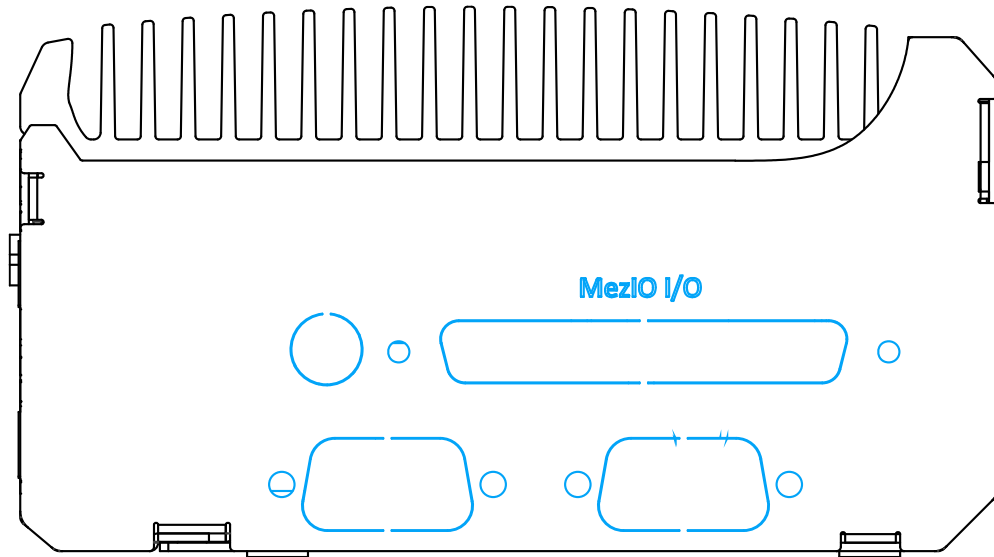

## 2.6 POC-900 Series Internal I/O

The system's internal I/O connectors consist of a SO-DIMM socket, M.2 2280 M key slot, mini-PCIe and a MezIO® port for application-oriented expansion purposes.

### 2.6.1 SO-DIMM Memory Socket



The system has an internal SO-DIMM slot supporting a single DDR5-5600 memory module up to 32GB in capacity.

### 2.6.2 M.2 2280 M Key

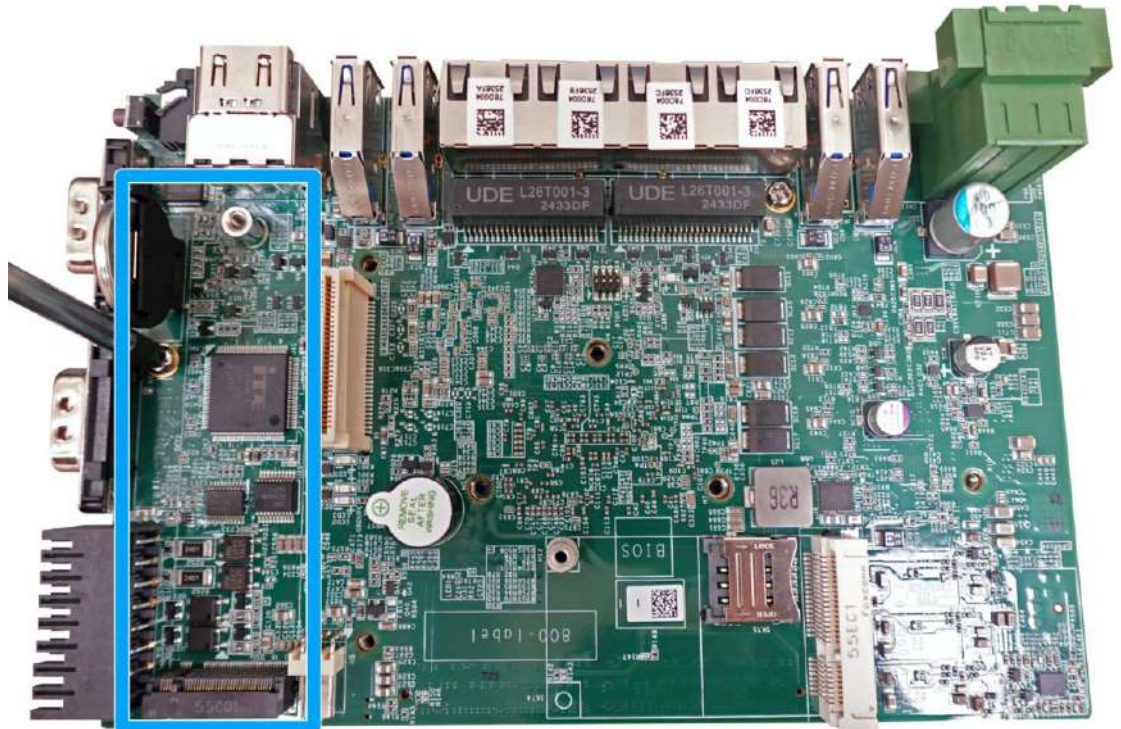

The system has a Gen4 x4 PCIe M.2 2280 slot for you to install an NVMe SSD. The M.2 NVMe SSD offers significantly better system performances when compared to a 2.5" SSD.

**M.2 2280 M Key Pin Definition**

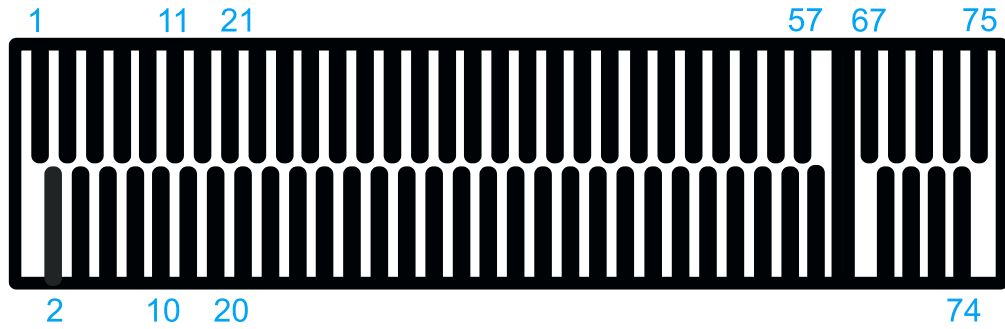

Pin #	Signal	Pin #	Signal
1	GND	2	+3V3
3	GND	4	+3V3
5	PERN3	6	-
7	PERP3	8	-
9	GND	10	DAS/DSS N
11	PETN3	12	+3V3
13	PETP3	14	+3V3
15	GND	16	+3V3
17	PERN2	18	+3V3
19	PERP2	20	-
21	GND	22	-
23	PETN2	24	-
25	PETP2	26	-
27	GND	28	-
29	PERN1	30	-
31	PERP1	32	-
33	GND	34	-
35	PETN1	36	-
37	PETP1	38	-
39	GND	40	-
41	PERn0	42	-
43	PERp0	44	-
45	GND	46	-
47	PETn0	48	-
49	PETp0	50	PERST N
51	GND	52	-
53	REFCLKN	54	-
55	REFCLKP	56	-
57	GND	58	-
<b>Mechanical Key</b>			
67	-	68	SUSCLK
69	PEDET	70	+3V3
71	GND	72	+3V3
73	GND	74	+3V3
75	GND		

### 2.6.3 Mini-PCle Slot

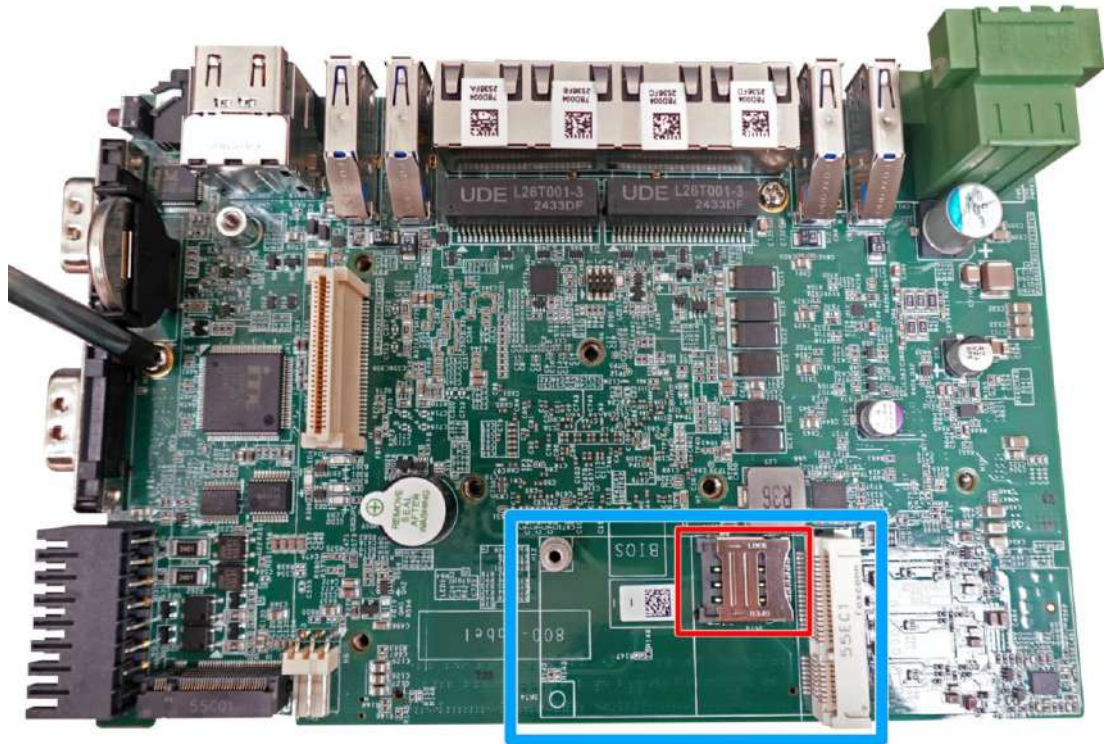

The system is equipped with a mini-PCle slots (in **blue**), each coupled with a Micro-SIM socket (indicated in **red**) for installing 5G/4G modules.

For wireless communication, multiple SMA antenna apertures can be located on the side.

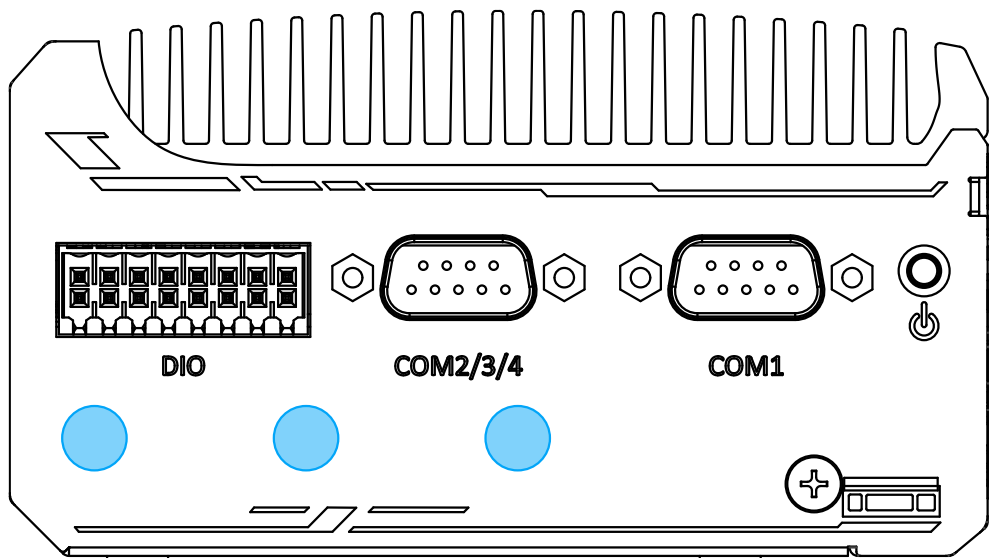

**mini-PCle socket definition**

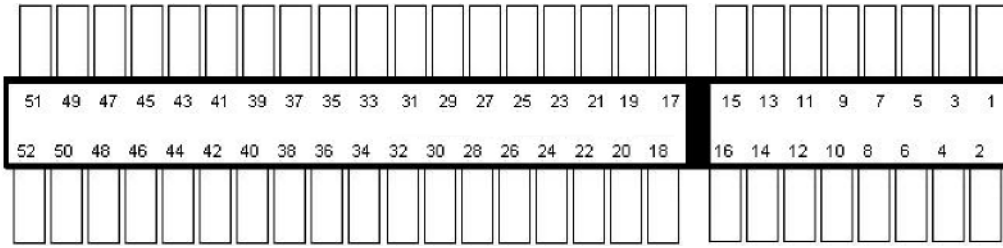

Pin #	Signal	Pin #	Signal
1	WAKE#	2	+3.3Vaux
3	COEX1	4	GND
5	COEX2	6	+1.5V
7	CLKREQ#	8	UIM PWR
9	GND	10	UIM DATA
11	REFCLK-	12	UIM CLK
13	REFCLK+	14	UIM RESET
15	GND	16	UIM VPP
<b>Mechanical Key</b>			
17	Reserved* (UIM C8)	18	GND
19	Reserved* (UIM C4)	20	W DISABLE#
21	GND	22	PERST#
23	PERn0	24	+3.3Vaux
25	PERp0	26	GND
27	GND	28	+1.5V
29	GND	30	SMB CLK
31	PETn0	32	SMB DATA
33	PETp0	34	GND
35	GND	36	USB D-
37	GND	38	USB D+
39	+3.3Vaux	40	GND
41	+3.3Vaux	42	Reserved
43	GND	44	Reserved
45	Reserved	46	Reserved
47	Reserved	48	+1.5V
49	Reserved	50	GND
51	Reserved	52	+3.3Vaux

**NOTE**

*Some off-the-shelf mini-PCle 5G/4G modules are not compliant to standard mini-PCle interface. They use 1.8V I/O signals instead of standard 3.3V I/O and may cause signal conflict. Please consult with Neousys for compatibility when in doubt! Installing an incompatible 4G module may damage the system or the module itself may be damaged.*

## 2.7 MezIO® Interface

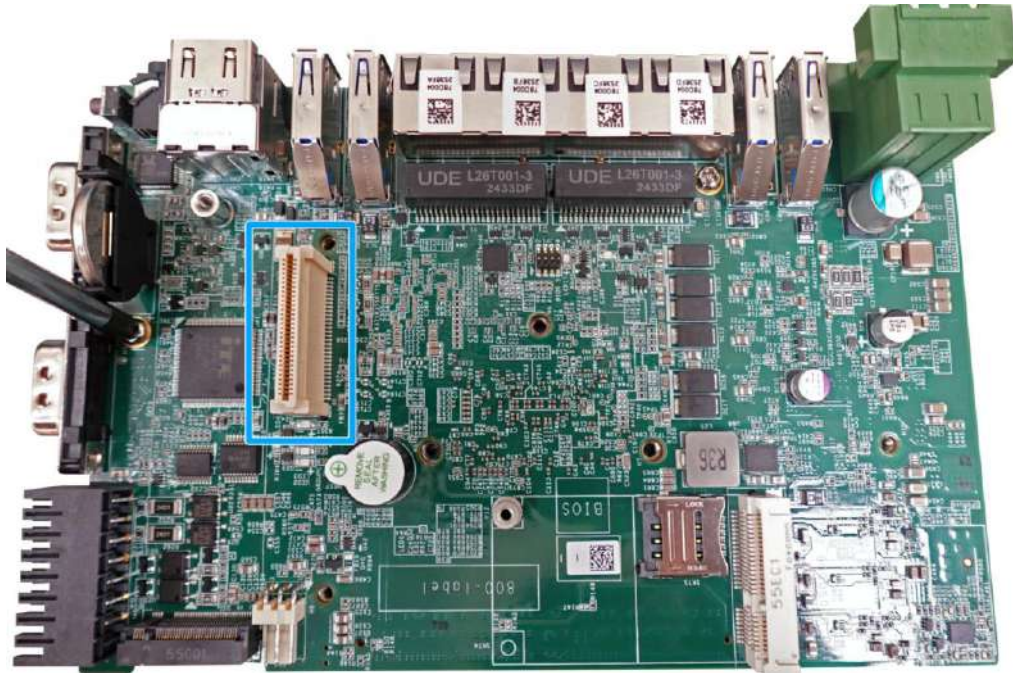

MezIO® is an innovative interface designed for integrating application-oriented I/O functions into an embedded system. It offers computer signals, power rails and control signals via a high-speed connector. MezIO® is also mechanically reliable benefited from its 3-point mounted mezzanine structure. A MezIO® module can leverage these signals to implement comprehensive I/O functions.

POC-900 series incorporates MezIO® interface and universal mechanical design to accommodate Neusys' standard MezIO® modules. For customers who want to develop their own MezIO® module, Neusys provides MezIO® design documents on a NDA basis. Please contact Neusys for further information.

### 2.7.1 MezIO® Interface Pin Definition



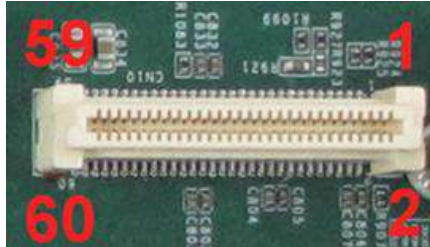





MezIO® interface leverages FCI BERGSTAK® board-to-board connector to provide interconnectivity of high-speed signals. The receptacle part on the PCBA is FCI 61082-064402LF while the plug part on the MezIO® module is FCI 61083-064402LF. Please refer to the following table for signal definition of its 60-pos connector.



Function Description	Signal	Pin#	Pin#	Signal	Function Description
Reserved	Reserved	1	2	PCIE TXP 0	PCIe data pair
Reserved	Reserved	3	4	PCIE TXN 0	PCIe data pair
Reserved	Reserved	5	6	GND	Ground
Reserved	Reserved	7	8	PCIE RXP 0	PCIe data pair
System S4 signal	SLP S4#	9	10	PCIE RXN 0	PCIe data pair
Ground	GND	11	12	CLK100 P 0	PCIe clock pair
Reserved	Reserved	13	14	CLK100 N 0	PCIe clock pair
Ground	GND	15	16	GND	Ground
Reserved	UID LED	17	18	PCIE TXP 1	PCIe data pair
Platform reset	PLT RST#	19	20	PCIE TXN 1	PCIe data pair
USB data pair	USBP5 N	21	22	PCIE RXP 1	PCIe data pair
USB data pair	USBP5 P	23	24	PCIE RXN 1	PCIe data pair
Ground	GND	25	26	GND	Ground
SMB bus	SMB DATA	27	28	CLK100 P 1	PCIe clock pair
SMB bus	SMB CLK	29	30	CLK100 N 1	PCIe clock pair
N/C	N/C	31	32	GND	Ground
N/C	N/C	33	34	N/C	N/C
Ground	GND	35	36	N/C	N/C
N/C	N/C	37	38	GND	Ground
N/C	N/C	39	40	N/C	N/C
Power button	PWRBTN#	41	42	N/C	N/C
Reserved	Reserved	43	44	RXD4	SIO COM4
PCH GPIO	GPIO RISE	45	46	TXD4	SIO COM4
PCH GPIO	GPIO RISE	47	48	RXD5	SIO COM5
PCH GPIO	GPIO RISE	49	50	TXD5	SIO COM5
Ground	GND	51	52	GND	Ground
3.3V power	P3V3	53	54	P1V8	1.8V power
3.3V power	P3V3	55	56	GND	Ground
5V power	P5V	57	58	P12V	12V power
5V power	P5V	59	60	P12V	12V power

### 2.7.2 MezIO® Modules for POC-900 Series

Neousys offers MezIO® modules to expand I/O functions for Neousys systems. With the addition of a MezIO® module into your system, it offers extra RS-232/ 422/ 485 ports, isolated digital I/ O, USB or ignition power control.

Model	Description	Product Photo
<b>MezIO-C180-50</b>	4-port RS-232/422/485 + 4-port RS-232	
<b>MezIO-C181-50</b>	4-port RS-232/422/485 + 4-port RS-422/485	
<b>MezIO-V21</b>	16-mode ignition power control and 1x mini-PCIe socket (USB2.0 + PCIe signal) for in-vehicle usage	
<b>MezIO-U4-30</b>	4x USB3.1 Gen1 ports	
<b>MezIO-D330</b>	16-CH isolated DI 16-CH isolated DO	
<b>MezIO-V21</b>	16-mode ignition power control and 1x mini-PCIe socket (USB2.0 + PCIe signal) for in-vehicle usage	
<b>MezIO-U4-50</b>	4x USB3.1 Gen1 ports	
<b>MezIO-D330</b>	16-CH isolated DI 16-CH isolated DO	

## 3 System Installation

Before disassembling the system enclosure and installing components and modules, please make sure you have done the following:

- It is recommended that only qualified service personnel should install and service this product to avoid injury or damage to the system.
- Please observe all ESD procedures at all times to avoid damaging the equipment.
- Before disassembling your system, please make sure the system has powered off, all cables and antennas (power, video, data, etc.) are disconnected.
- Place the system on a flat and sturdy surface (remove from mounts or out of server cabinets) before proceeding with the installation/ replacement procedure.

### 3.1 Disassembling the System Enclosure

To install necessary components such as memory module, M.2 modules or MezIO® module, you need to disassemble the POC-900 system enclosure:

1. To disassemble POC-900, remove the screws on the rear panel.



2. Remove the hex-bolt on COM ports.



3. Unfasten the screws at the bottom of the enclosure.



4. Gently slide the enclosure open.



5. Remove the screws indicated on the I/O panel, and remove the panel.



6. Remove the screw holding the DIO panel, and separate the DIO panel.



## 3.2 Installing Internal Components

### 3.2.1 SO-DIMM Installation

There is one SO-DIMM memory slot on POC-900 series motherboard. Please follow the procedures below to install the memory module.

1. [Disassemble the system enclosure](#)
2. Remove the screws securing the NVMe heatsink.



3. Remove the **screws** indicated on the motherboard.

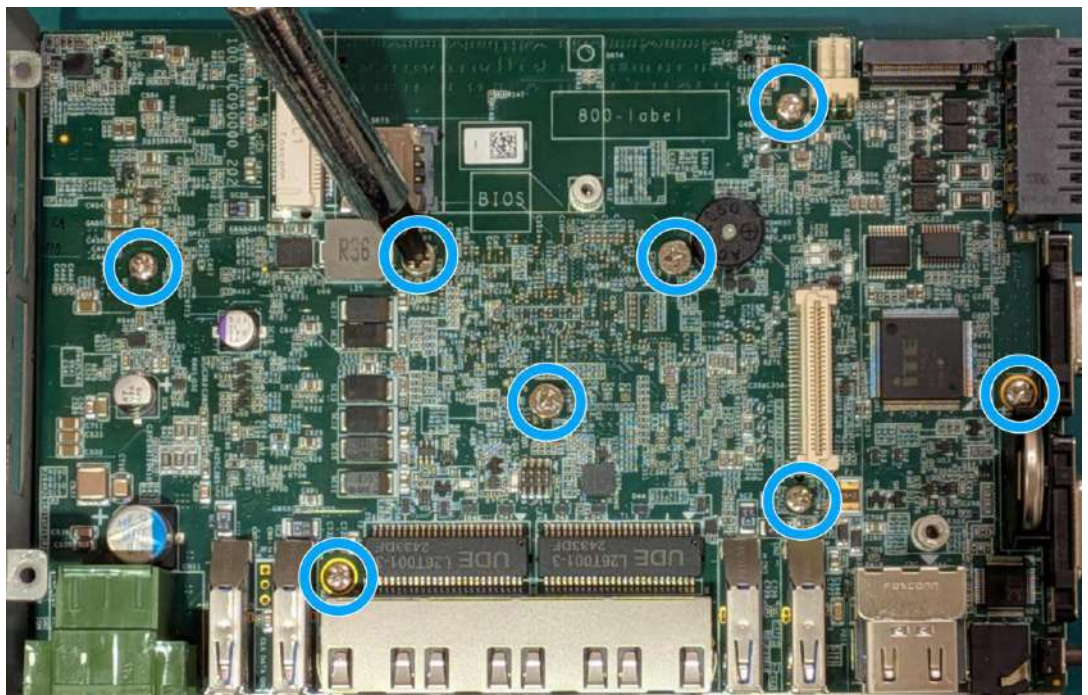

4. Separate the motherboard from the heatsink, turn the motherboard upside-down, and the SO-DIMM slot can be located.

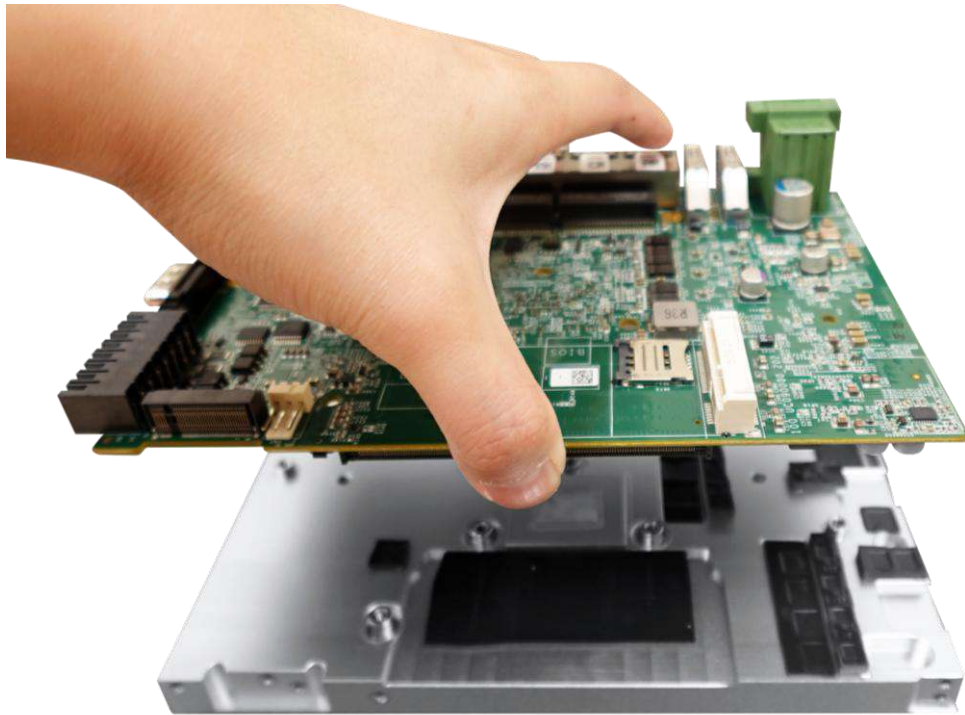

5. **To install**, insert the gold finger end of the SO-DIMM on a 45 degree angle.

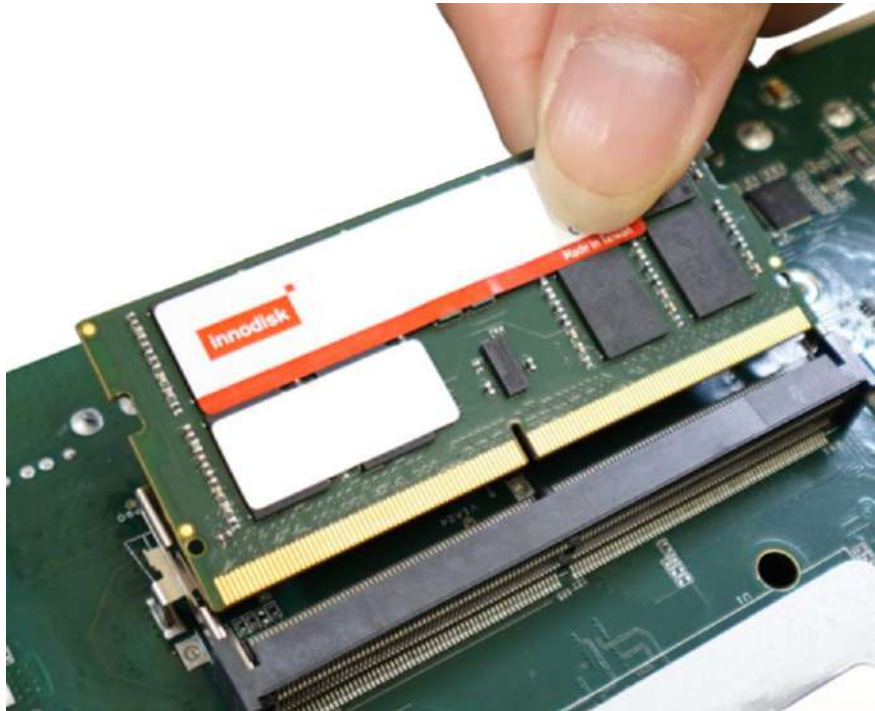

6. Gently push the SO-DIMM down until it clips-in.

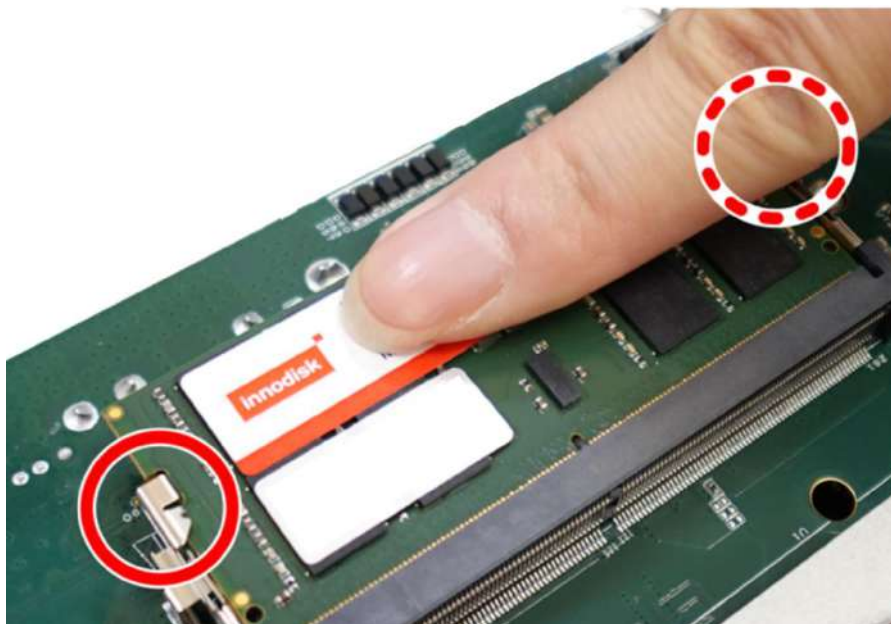

- Remove the memory thermal pad protection film on the heatsink indicated in blue, and all other thermal pad protection films in indicated with a red arrow.

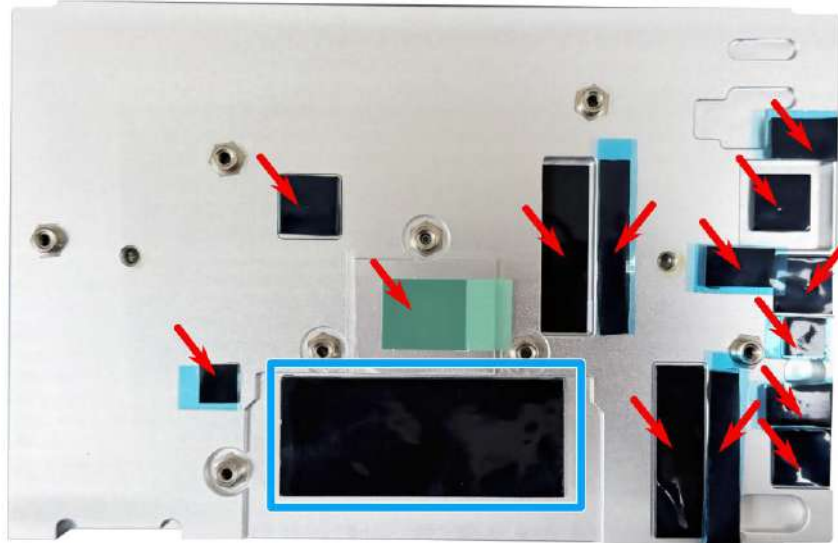

- Turn the motherboard right side-up, lower it onto the heatsink.

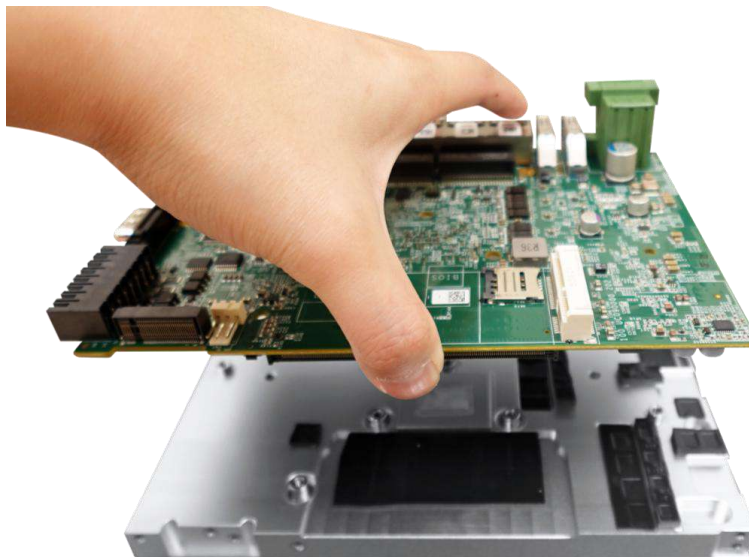

- Secure the motherboard by fastening the **screws** indicated

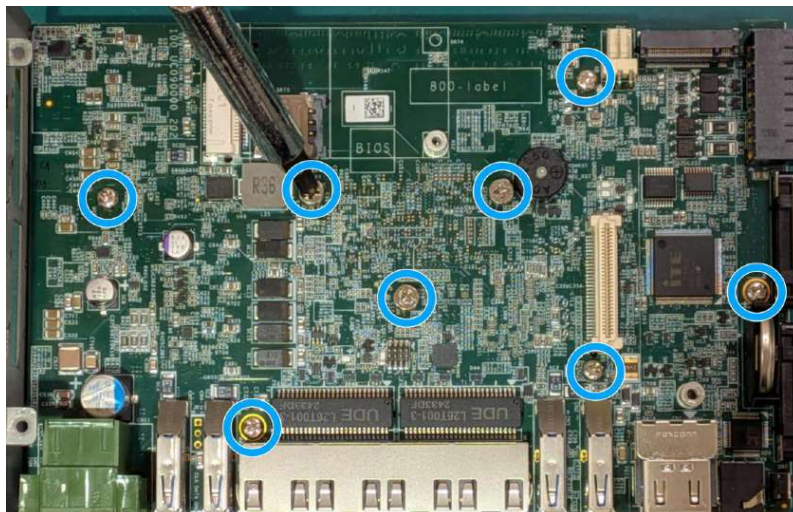

10. Reinstall the NVMe heatsink.



11. [Reinstall the system enclosure.](#)

### 3.2.2 M.2 2280 M Key Module Installation

There is an M.2 2280 M key module expansion slot on POC-900 series motherboard. Please follow the procedures below for installation.

1. [Disassemble the system enclosure.](#)
2. Remove the screws securing the NVMe heatsink.



3. The M.2 2280 M key expansion can be located once the heatsink has been removed.

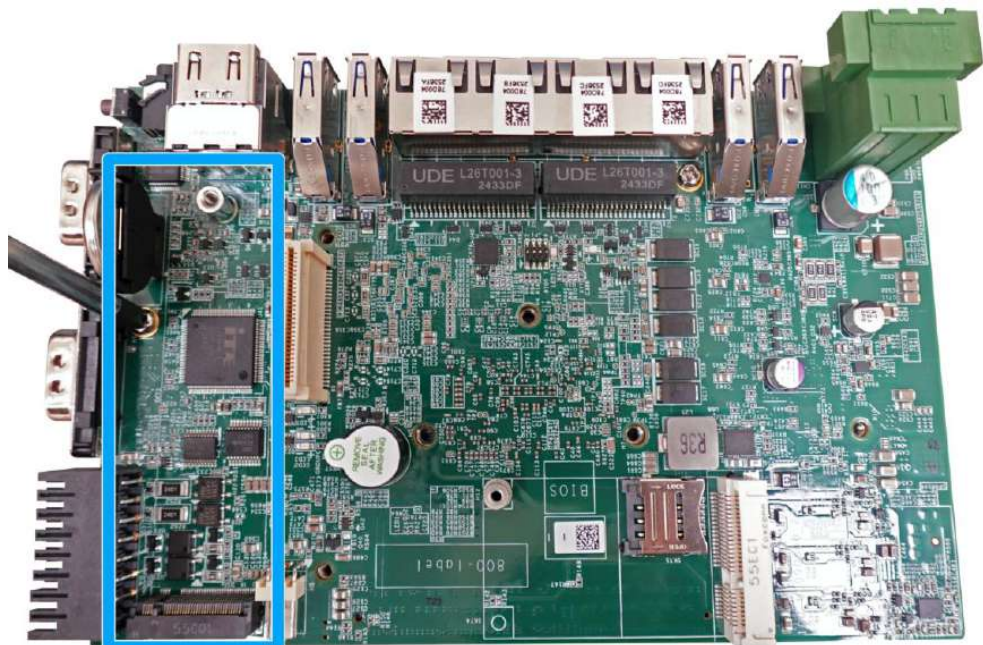



### 3.2.3 mini-PCle Module Installation

The system has a **mini-PCle slot** coupled with **Micro-SIM socket** for installing 5G/4G module. For installation, please refer to the following instructions.

1. Please refer to the section "[Disassembling the System](#)".
2. Locate the mini-PCle and SIM card slots on the motherboard.

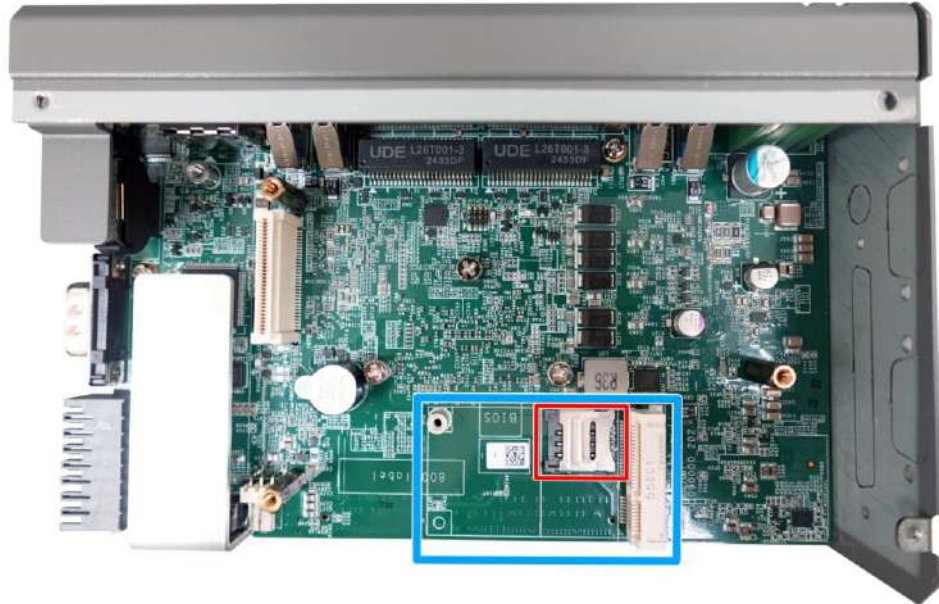

3. If you are installing a wireless module that requires a SIM, please install the SIM card first. Otherwise go to step 5. Push the SIM slot holder in the direction shown and flip open the holder to place the SIM into the slot.

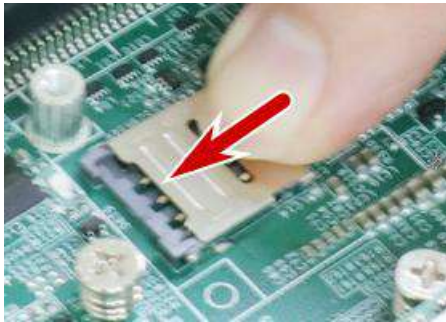

**Push the SIM holder in the direction shown**



**Flip open the holder and place SIM**

4. Flip the holder back onto the SIM card and push in the direction shown to lock-in the SIM card into the slot.



5. Insert the mPCIe module on a 45 degree angle into the mPCIe slot and secure the module.

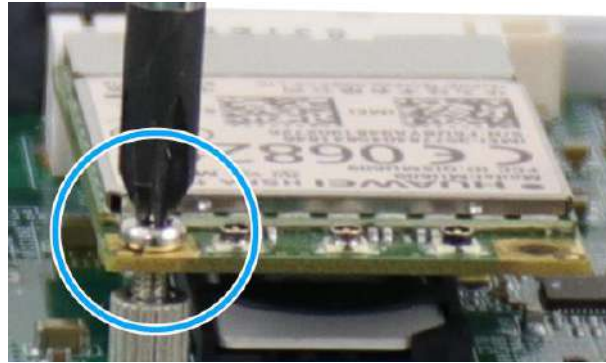

**Insert on 45 degree angle**

**Secure the module**

6. Clip on the IPEX-to-SMA cable to the module and secure the antenna to the front or rear panel. Please refer to the module's manual for clip-on connection.

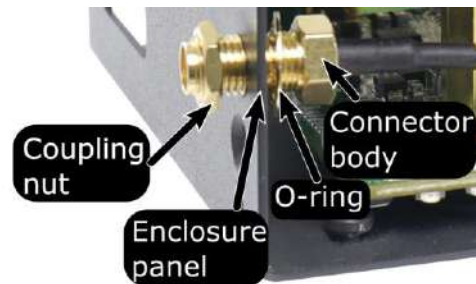

**Clip on IPEX-to-SMA cable**

**Secure antenna to panel**

7. [Reinstall the system enclosure](#) and panel when done.
8. If you need to install other components, please refer to respective sections.

### 3.2.4 MezIO® Module Installation

The system comes with a MezIO® module expansion slot. For specific MezIO® module I/O functionalities, please refer to the [MezIO® Module](#) section. For installation, please refer to the following procedure.

1. [Disassemble the system enclosure](#), but do not remove the NVMe heatsink.
2. The MezIO® module expansion slot can be located once the enclosure has been removed.

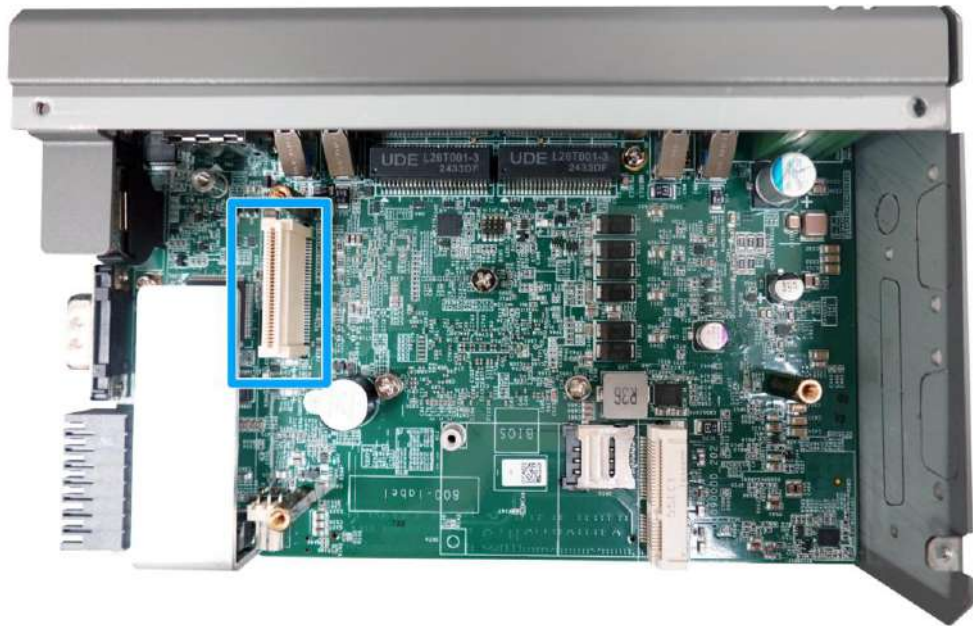

3. Remove the screws indicated in **blue**, for stand-off hex bolt installation to mount the MezIO® module.

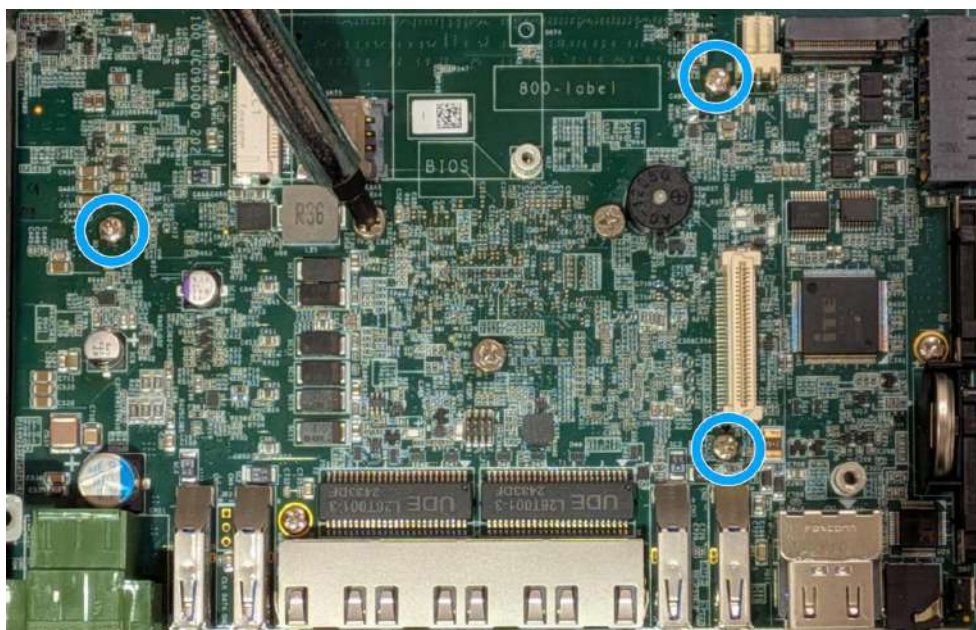

4. The stand-off hex bolts are shipped with MezIO® module. Install the stand-off hex bolts into the locations shown below.

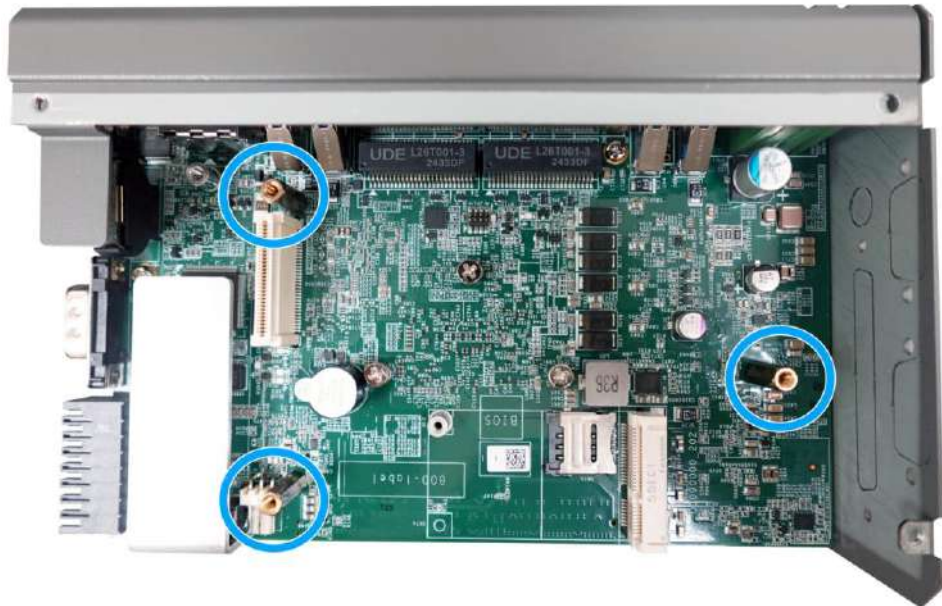

5. To install, match the three (3) screw holes to the standoffs and the MezIO® port, gently lower the module onto the PCBA. The MezIO® port should engage if the three (3) standoffs and screw holes meet.
6. Then using the three (3) screws supplied, secure the module by fastening a screw on each standoff.



7. If you are installing a new MezIO® module into your system, you may need to remove the punch-out plate depending on your MezIO® expansion needs.

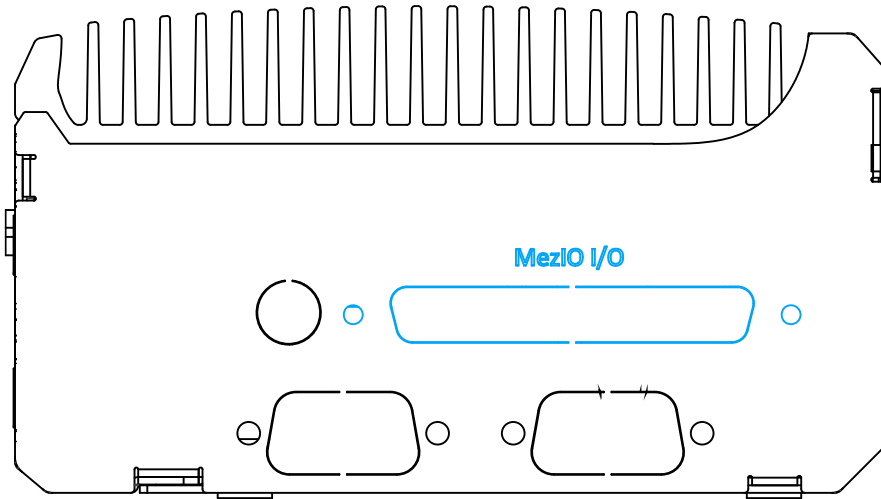

8. [Reinstall the system enclosure.](#)

### 3.3 Installing the System Enclosure

1. Reinstall the DIO panel by securing the screw indicated.



2. Gently slide the L-shaped enclosure back in place making sure the screw hole on the hinge sits on the inside.

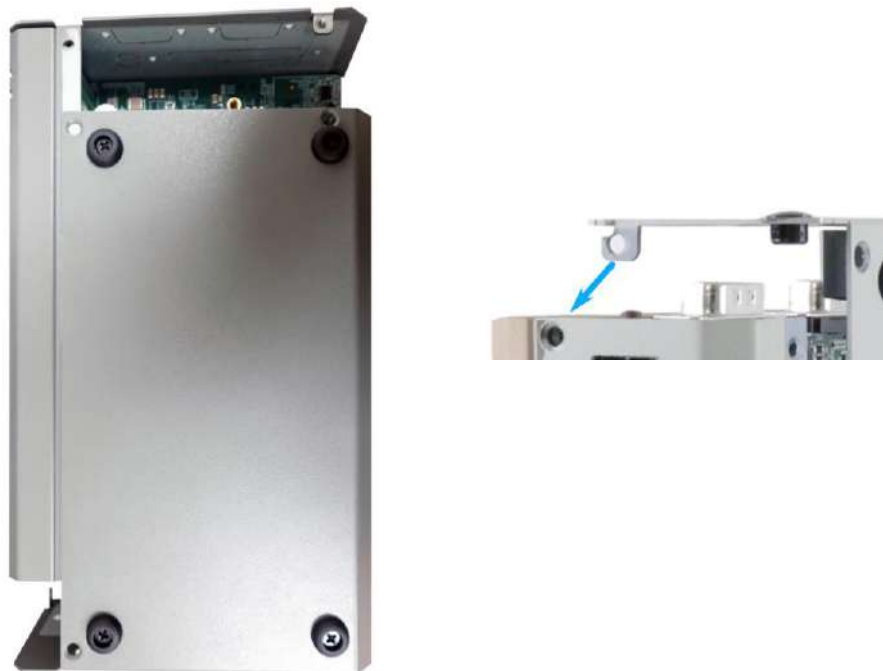

**Place enclosure back in-place**

**Make sure hinge sits on the inside**

3. Install the I/O panel and secure the screws indicated.



4. Complete installing the system enclosure by fastening the screws indicated below, and secure the ground screw..



**COM port hex-bolt**



**Rear panel**



**Bottom of the enclosure**



**Ground screw**

### 3.4 DIN Rail Installation

The DIN rail is easy to install and it is a convenient way to position the system. The DIN rail has been proven to be most beneficial in the industrial environment where space is limited. The mount plate comes with two M4 screws. Please refer to the illustrations below to install the DIN clip/ rail.

1. To install, secure the **DIN rail clip** onto the rear of the system enclosure using the **6mm M4 screws** provided.

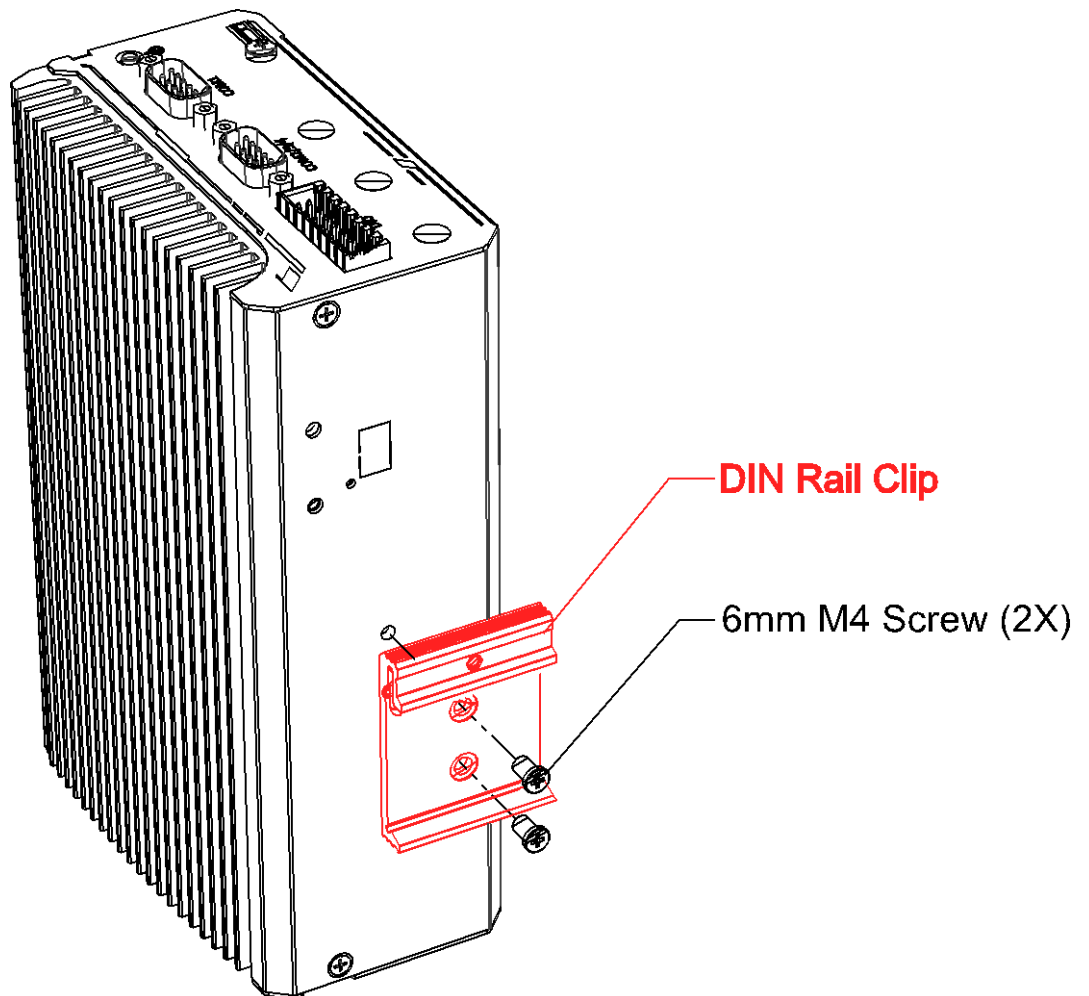

2. To install the mount plate onto the DIN rail, you must come over the top of the DIN rail, tilting downwards, overlap the top clip edge of the mount plate onto the DIN rail first, then firmly press the bottom-front of the enclosure to clip the bottom edge of the mount plate.

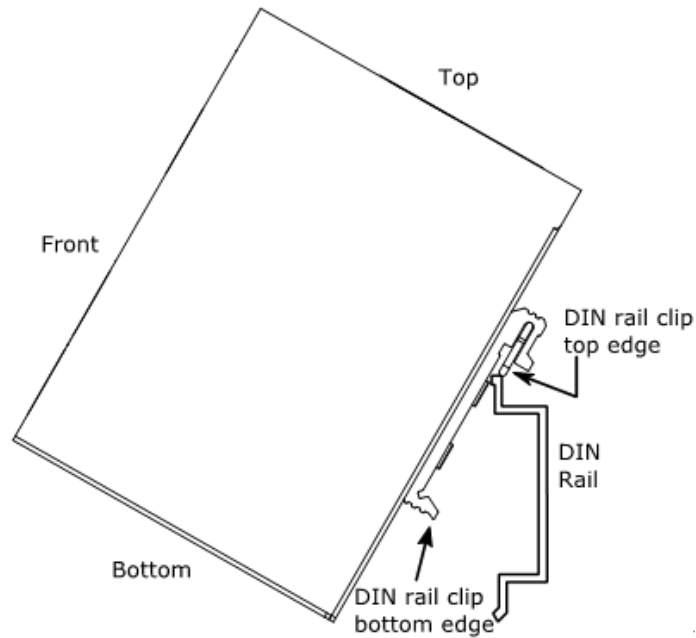

3. Confirm the mount plate has indeed clipped onto the DIN rail for proper fit to complete the installation.

### 3.5 Wall Mount Installation (Optional Accessory)

#### 3.5.1 Standard Wall Mount (Optional Accessory)

The optional wall mount bracket allows the system to be mounted horizontally. Please refer to the following installation procedure to install the wall mount.

1. Remove the rubber pads indicated at the bottom of the system.



2. To install, secure the **wall mount bracket** to the bottom of the system enclosure using the **6mm M4 screws** provided.

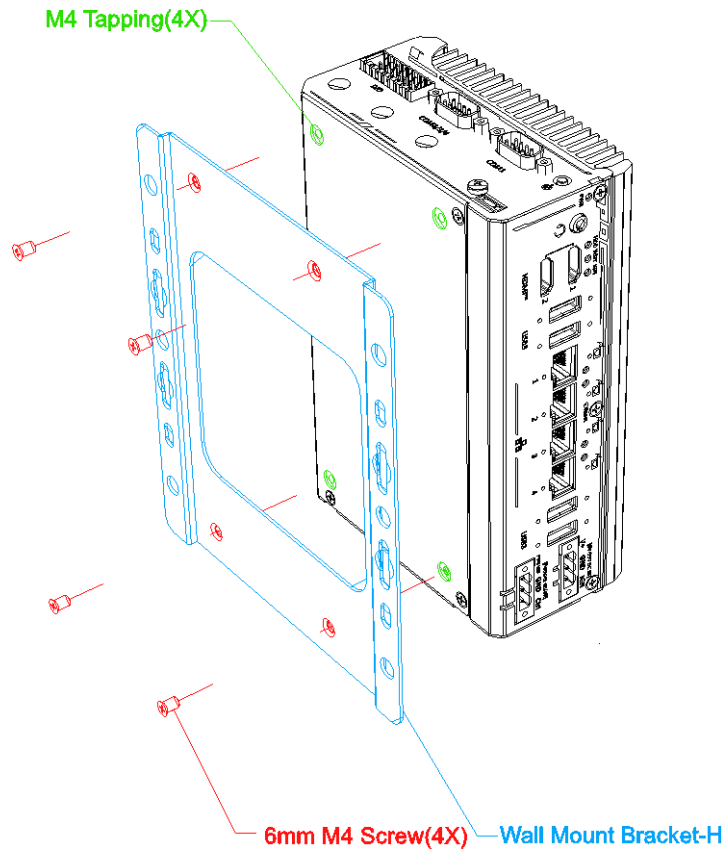

3. Dimension illustration of the installed wall mount bracket for your reference.

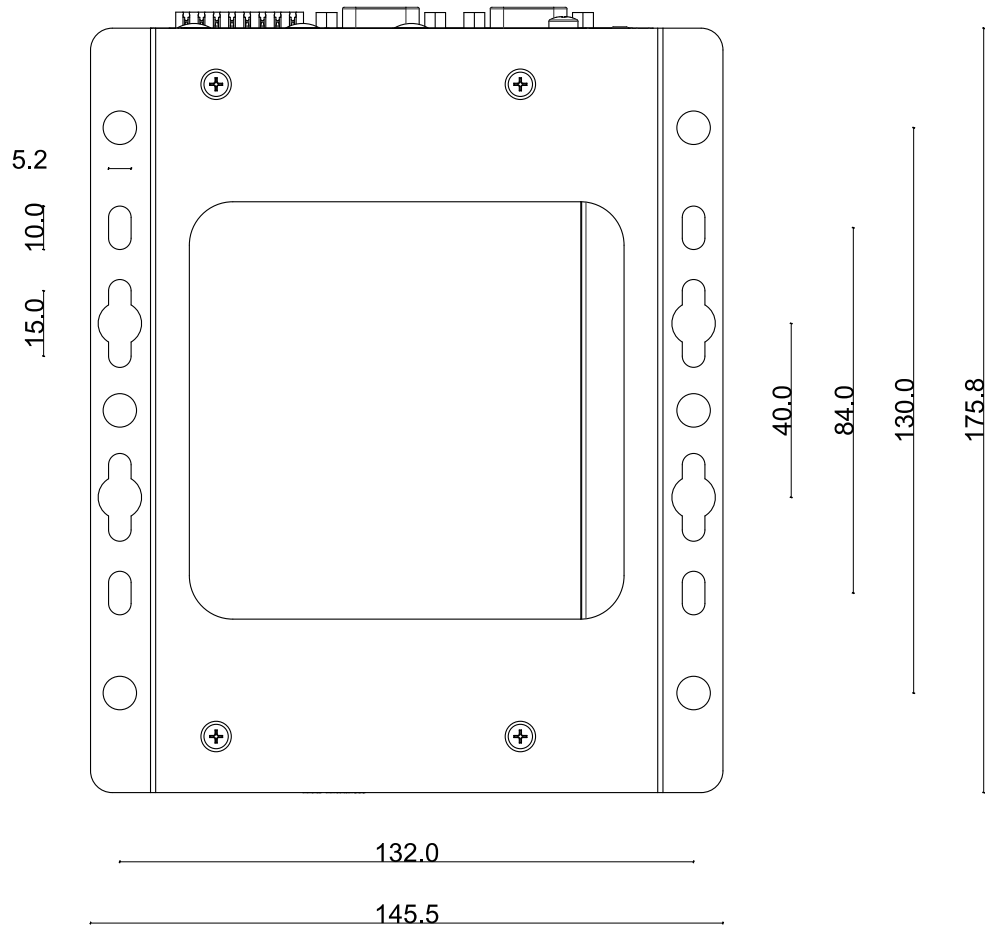

### 3.5.2 Vertical Wall Mount (Optional Accessory)

- To install, secure the **vertical wall mount bracket** to the rear side panel of the system enclosure using the **6mm M4 screws** provided.

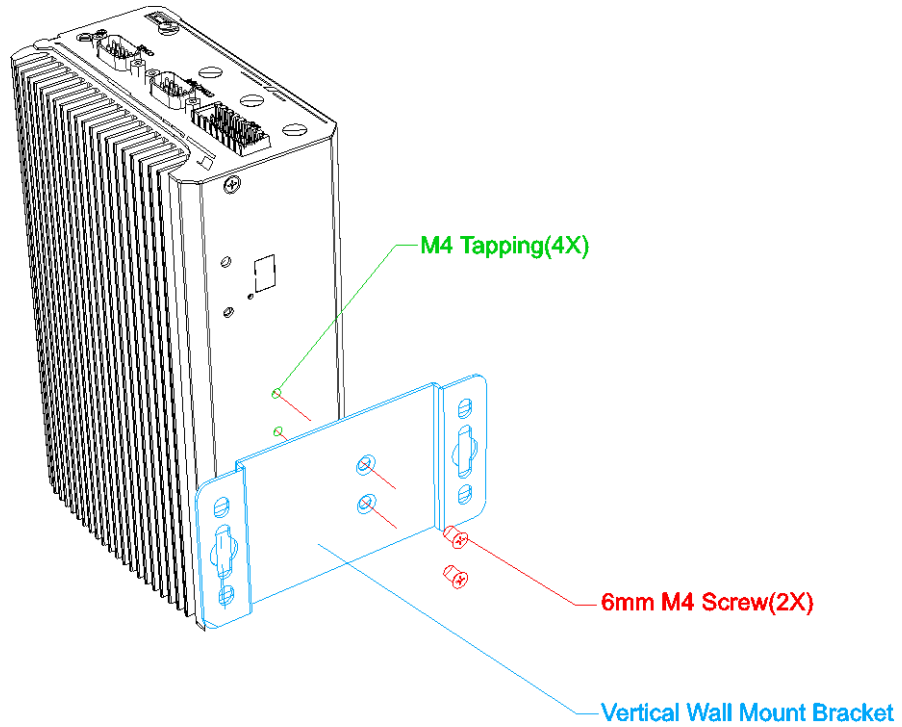

- Dimension illustration of the installed vertical wall mount bracket for your reference.

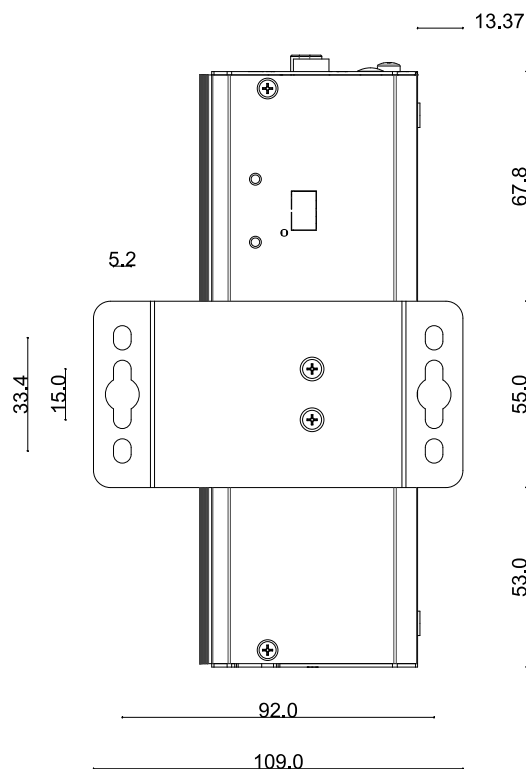

### 3.6 Powering On the System

There are various methods to power on the system

- Pressing the power button
- Via an external non-latched switch
- Sending a LAN packet via Ethernet (Wake-on-LAN)
- Using the ignition signal input (if MezIO-V21 is installed)

We will describe the processes and actions involved for the first four methods in this section and the ignition signal input method will be described in section 3.7.

#### 3.6.1 Powering On Using the Power Button

This is the simplest way to turn on your system. The power button on the front panel is a non-latched switch and behaves as the ATX-mode on/off control. With DC power connected, pushing the power button will turn on the system and the PWR LED indicator will light up. Pushing the button when system is on will turn off the system. If your operating system supports ATX power mode (i.e. Microsoft Windows or Linux), pushing the power button while the system is in operation will result in a pre-defined system behavior, such as shutdown or hibernation.

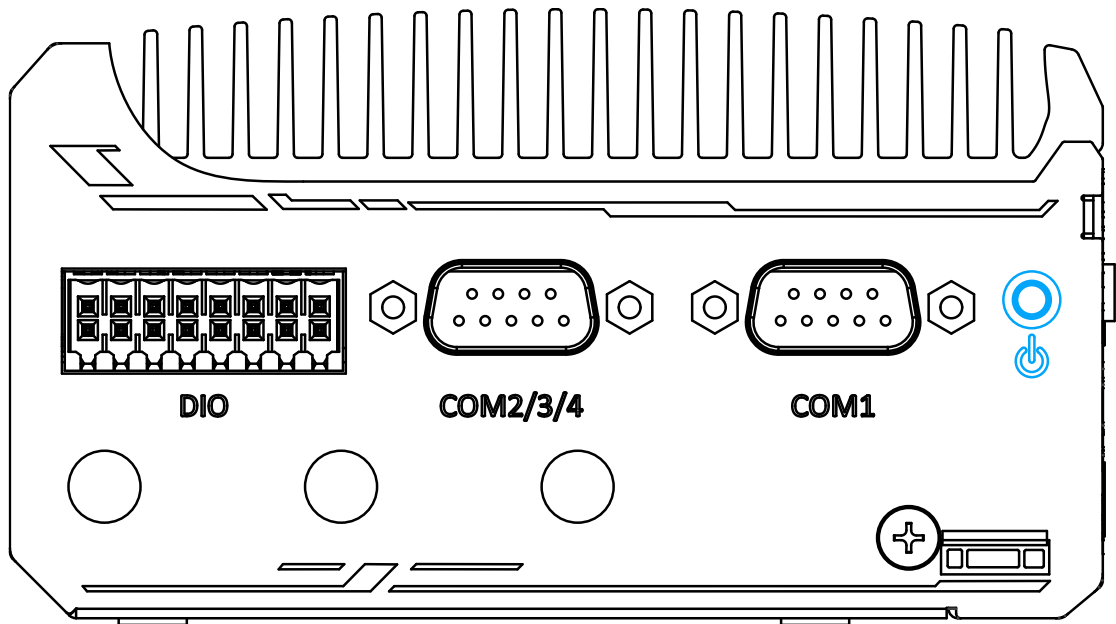

### 3.6.2 Powering On Using An External Non-Latched Switch

For an application which places the system inside a cabinet, it's useful to control powering on/off the system using an external switch. The system provides an on-board connector for connecting a latched/ non-latched switch and behaving either AT-mode or ATX-mode power on/off control.

When using the ATX-mode on/ off control, you need a non-latch switch. The external non-latched switch acts exactly the same as the power button on the front panel. Please follow the steps below to install an external non-latch switch.

1. Acquire a non-latched switch with 3-pin plug.
2. Connect the non-latched switch to the Remote On/ Off plug.

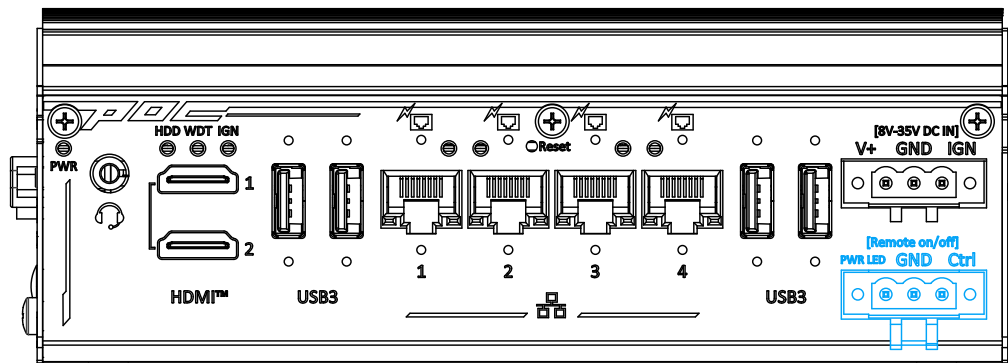

3. With DC power connected, pushing the power button will turn on the system and the PWR LED indicator will light up. Pushing the button when system is on will turn off the system. If your operating system supports ATX power mode (i.e. Microsoft Windows or Linux), pushing the power button while the system is in operation will result in a pre-defined system behavior, such as shutdown or hibernation.

### 3.6.3 Powering On Using Wake-on-LAN

Wake-on-LAN (WOL) is a mechanism to wake up a computer system from a S4/ S5 state via issuing a magic packet. The system's Wake-on-LAN compatible port is shown below.

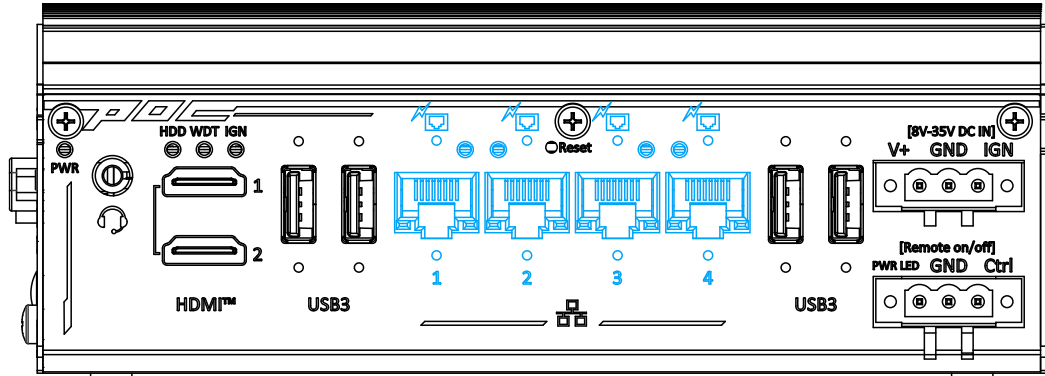

 **NOTE**

*Please make sure the Intel chipset and Ethernet driver has been properly installed prior to setting up WOL function.*

To enable WOL function, please set up WOL settings in the BIOS and in the operating system by follow the steps described below.

1. When the system boots up, press F2 to enter BIOS setup utility.
2. Go to the **[Power]>[Wake On LAN]** and set it to **[Enabled]**.
3. Press F10 to **“Save changes and exit BIOS”** and allow the system boot into the operating system.
4. Once booted into the Windows system, press **“Windows key + E”**, right-click on **“Network>Properties>Change adapter settings”**. Locate and double-click on the adapter Intel® I350 Gigabit Network Connection, click on **Configure**.
5. Click on the **Power Management** tab and check the following options. Click on OK when done.

**Magic Packet**

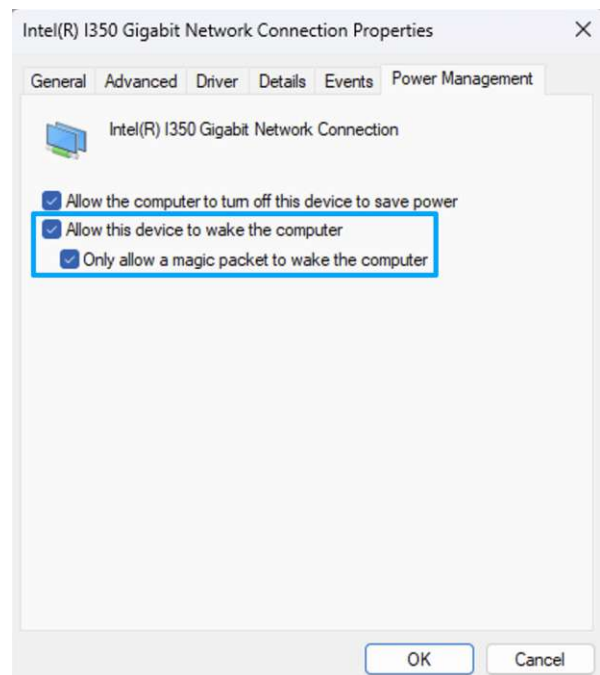

The magic packet is a broadcast frame containing anywhere within its payload 6 bytes of all 255 (FF FF FF FF FF FF in hexadecimal), followed by sixteen repetitions of the target computer's 48-bit MAC address.

For example, NIC's 48-bit MAC Address is 78h D0h 04h 0Ah 0Bh 0Ch

DESTINATION SOURCE MISC

FF FF FF FF FF FF

78 D0 04 0A 0B 0C 78 D0 04 0A 0B 0C

78 D0 04 0A 0B 0C 78 D0 04 0A 0B 0C

78 D0 04 0A 0B 0C 78 D0 04 0A 0B 0C

78 D0 04 0A 0B 0C 78 D0 04 0A 0B 0C

78 D0 04 0A 0B 0C 78 D0 04 0A 0B 0C

78 D0 04 0A 0B 0C 78 D0 04 0A 0B 0C

78 D0 04 0A 0B 0C 78 D0 04 0A 0B 0C

78 D0 04 0A 0B 0C 78 D0 04 0A 0B 0C

MISC      CRC

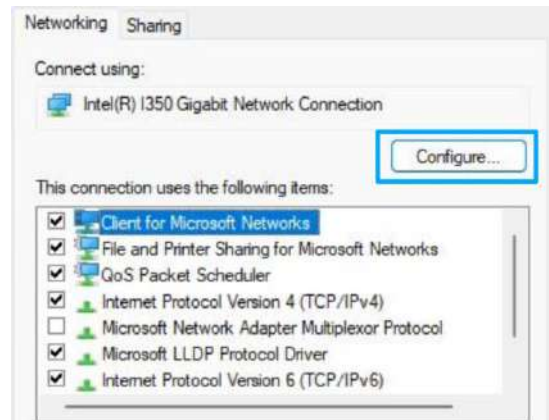

There are some free tools available on Internet that can be used to send a magic packet. Please refer to the following link to understand more about [Magic Packet](#).

# 4 BIOS Settings

The system is shipped with factory-default BIOS settings optimized for best performance and compatibility. In this section, we'll illustrate some BIOS settings you may need to set or change prior to operating system installation. Please always make sure you understand the effect of change before you proceed with any changes. If you are unsure of the function you are changing, it is recommended to change one setting at a time to see its effect(s).

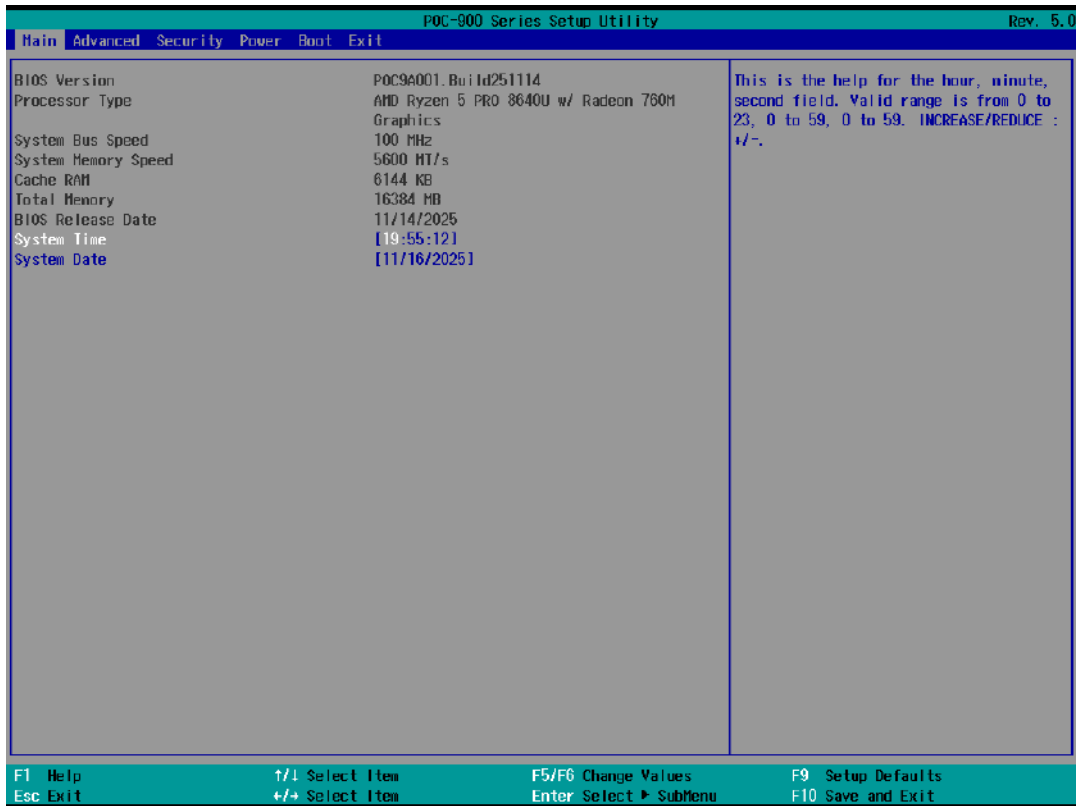

 **NOTE**

*Not all BIOS settings will be discussed in this section. If there is a particular BIOS setting you are after but is not discussed in this section, please contact Neousys Technical Support staff.*

## 4.1 COM1 Port Configuration

The system's [COM1 port](#) supports RS-232 (full-duplex), RS-422 (full-duplex) and RS-485 (half-duplex) mode. You can set the COM1 operating mode via BIOS settings. Another option in BIOS called “*Slew Rate*” defines how sharp the rising/falling edge is for the output signal of COM1. For long-distance RS-422/485 transmission, you may set the “*Slew Rate*” option as “High” to improve signal quality. For RS-422/485 communication, the “*RS-422/485 Termination*” option determines whether to enable/disable internal termination of RS-422/485 transceiver according to your wiring configuration (e.g. with or without external termination).

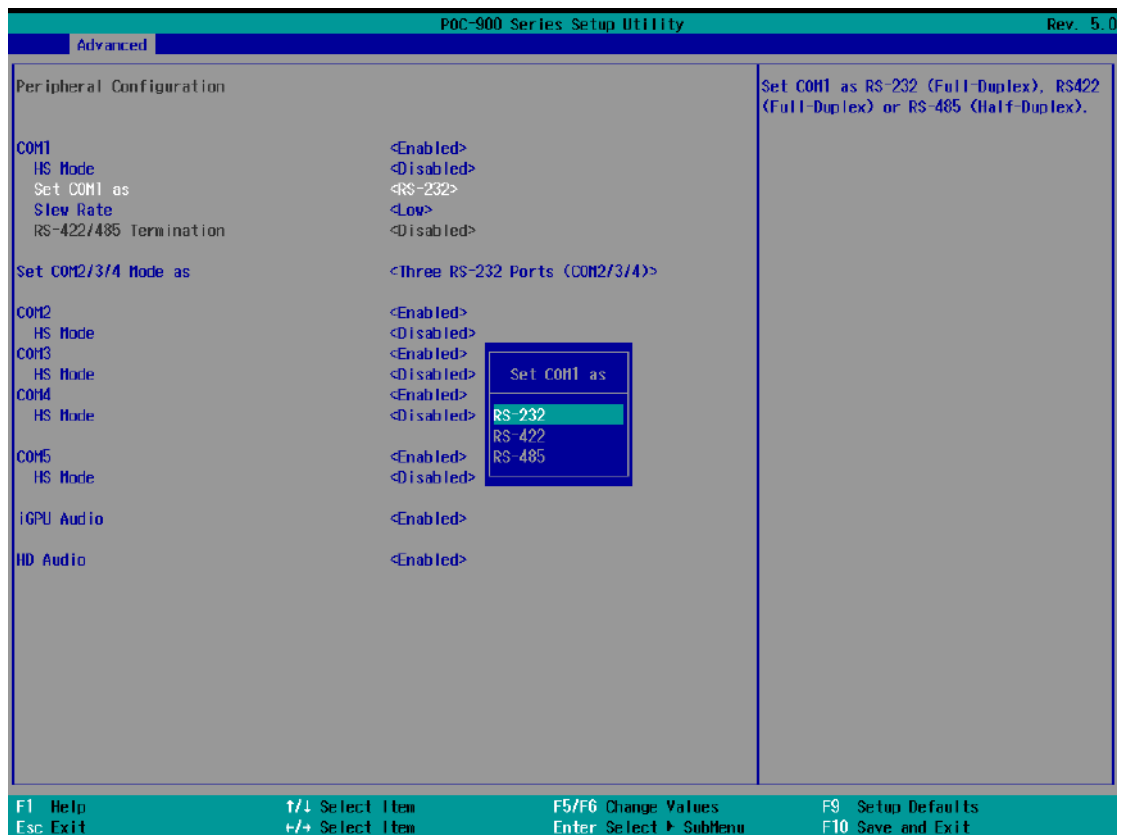

### To set COM1 operating mode:

1. Press **F2** when the system boots up to enter the BIOS setup utility.
2. Go to **[Advanced]** → **[Peripheral Configuration]**.
3. Set the **[Set COM1 Mode as]** option to the desired mode.
4. Once set, press **F10** to save setting and exit.

### 4.1.1 COM Port High Speed Mode

The high speed mode of each COM port effectively allows for the port's baud rate generator to operate at 8x the speed with an effective baud rate of 921,600 bps (115,200 x 8). Please refer to the following instructions on how to enable the high speed mode for your COM port (COM1 used as an example).



**To set COM port high speed mode:**

1. Press **F2** when the system boots up to enter the BIOS setup utility.
2. Go to **[Advanced] > [Peripheral Configuration]**.
3. Enable or set the **[Set COM1 Mode as]** option to the desired mode.
4. Highlight **[HS Mode]** and press ENTER to bring up options, highlight **[Enable]** and press ENTER.
5. Once set, press **F10** to save setting and exit.

### 4.1.2 COM Port Slew Rate

Another option in BIOS called “*Slew Rate*” defines how sharp the rising/falling edge is for the output signal of COM1. For long-distance RS-422/ 485 transmission, you may set the “*Slew Rate*” option as “High” to improve signal quality. For RS-422/485 communication, the “*RS-422/ 485 Termination*” option determines whether to enable/disable internal termination of RS-422/ 485 transceiver according to your wiring configuration (e.g. with or without external termination).

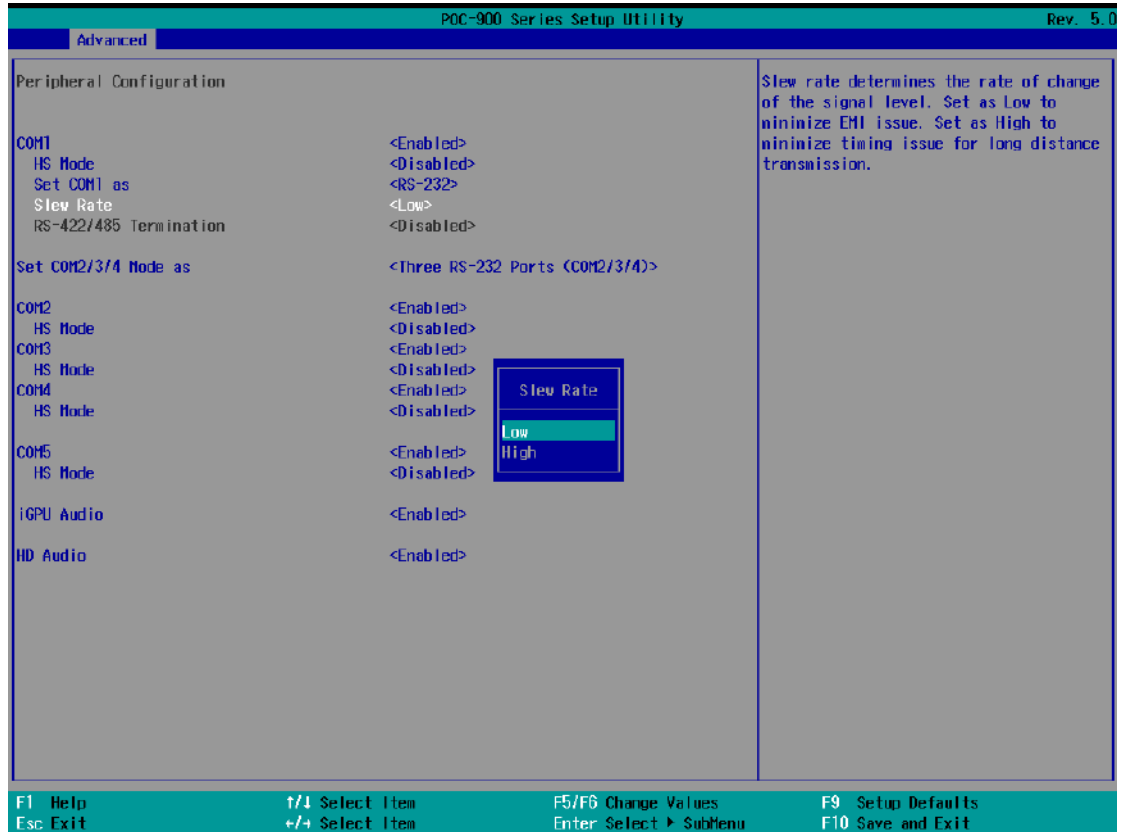

#### To set COM port Slew rate:

1. Press **F2** when the system boots up to enter the BIOS setup utility.
2. Go to **[Advanced]** → **[Peripheral Configuration]**.
3. Select and highlight the COM port > **[Slew Rate]**.
4. Set it to the desired mode **[Low]** or **[High]** and press Enter.
5. Once set, press **F10** to save setting and exit.

## 4.2 COM2/ 3/ 4 Port Configuration

The system's [COM2/ 3/ 4 ports](#) support RS-232 (full-duplex) while COM2 also supports RS-422 (full-duplex) and RS-485 (half-duplex) mode. The operating mode can be configured via the BIOS. Another option in BIOS called “Slew Rate” defines how sharp the rising/falling edge is for the output signal. For long-distance RS-422/485 transmission, you may set the “Slew Rate” option as “High” to improve signal quality. For RS-422/485 communication, the “RS-422/485 Termination” option determines whether to enable/disable internal termination of RS-422/485 transceiver according to your wiring configuration (e.g. with or without external termination).

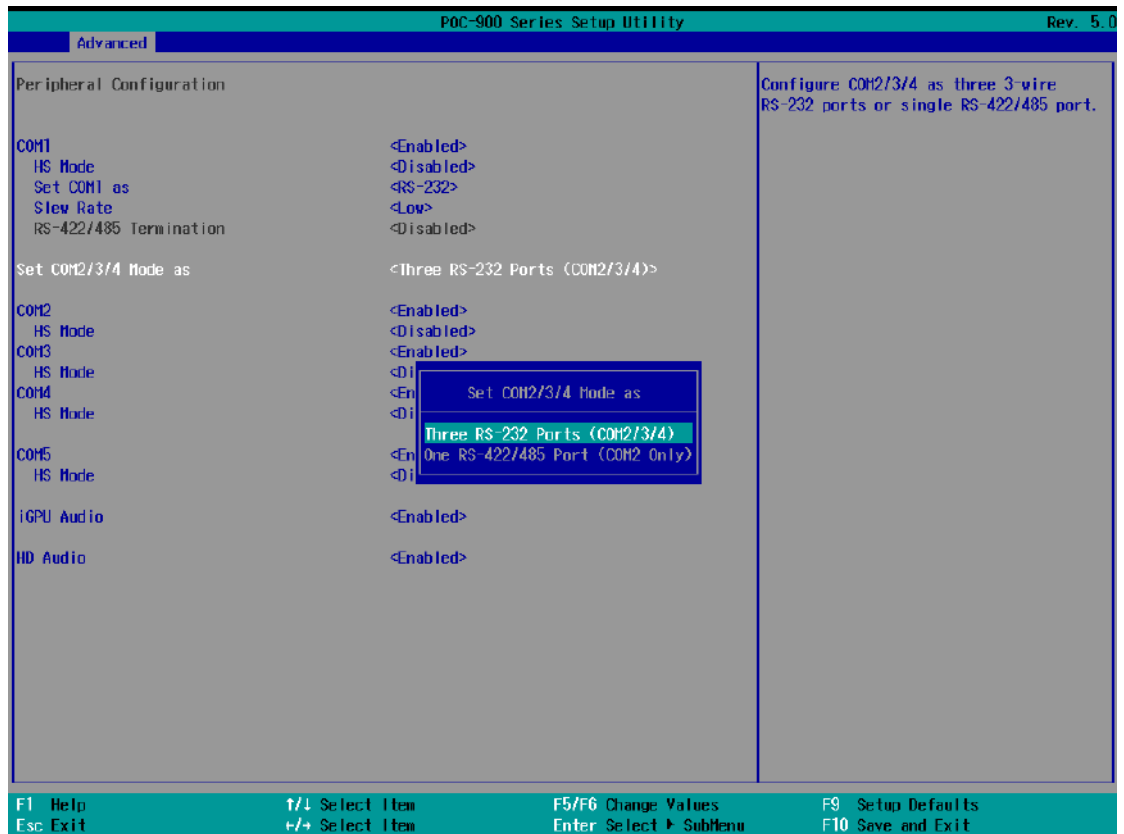

### To set COM2/ 3/ 4 operating mode:

1. Press **F2** when the system boots up to enter the BIOS setup utility.
2. Go to **[Advanced]** → **[Peripheral Configuration]**.
3. Set the **[Set COM2/ 3/ 4 Mode as]** option to the desired mode.
4. Once set, press **F10** to save setting and exit.

### 4.3 TPM Availability

Trusted Platform Module (TPM) is a hardware-based cryptoprocessor to secure hardware by integrating cryptographic keys into devices. The system is designed with on-board TPM 2.0 module. As TPM 2.0 requires 64-bit Windows 11 with UEFI boot mode, it is enabled in BIOS by default.



**To enable TPM availability:**

1. When system boots up, press F2 to enter BIOS setup utility.
2. Go to **[Security] > [TPM Availability]**, press ENTER to bring up Options, Available/ Hidden.
3. Highlight your selection, press Enter and press F10 to “Exit Saving Changes”.

## 4.4 Power over Ethernet

The Power over Ethernet (PoE) functionality is available on following ports, and it allows for the transmission of data and power delivery while utilizing a single Cat5 and higher grade Ethernet cable.

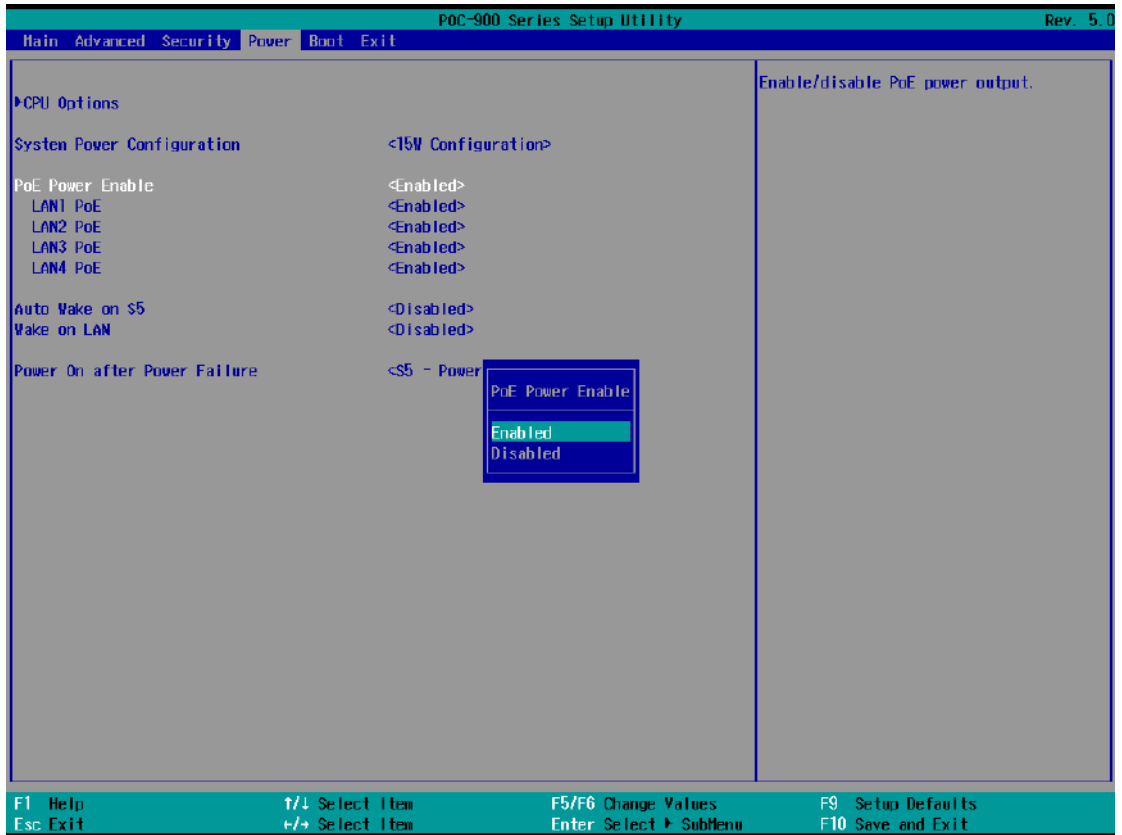

### To enable/disable “PoE Power Enable” option:

1. Press **F2** when the system boots up to enter the BIOS setup utility.
2. Go to [**Power**].
3. You may enable/disable the [**PoE Power Enable**] option.
4. When Enabled, you may set each LAN port’s PoE function by selecting Enabled/ Disabled using the arrow key, press Enter to make your selection.

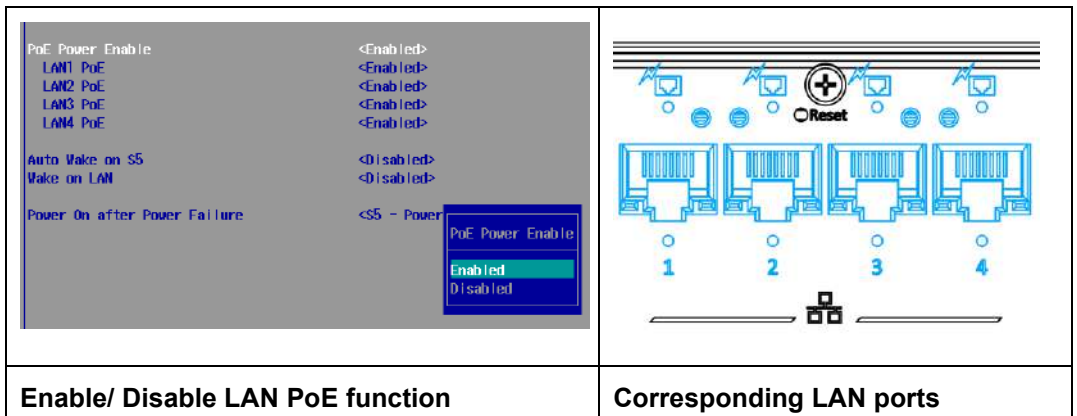

5. Once set, press **F10** to save setting and exit.

## 4.5 Wake-on-LAN

Wake-on-LAN (WOL) is a mechanism which allows you to turn on your system via Ethernet connection. To utilize Wake-on-LAN function, you have to enable this option first in BIOS settings. Please refer to Powering on via Wake-on-LAN function.

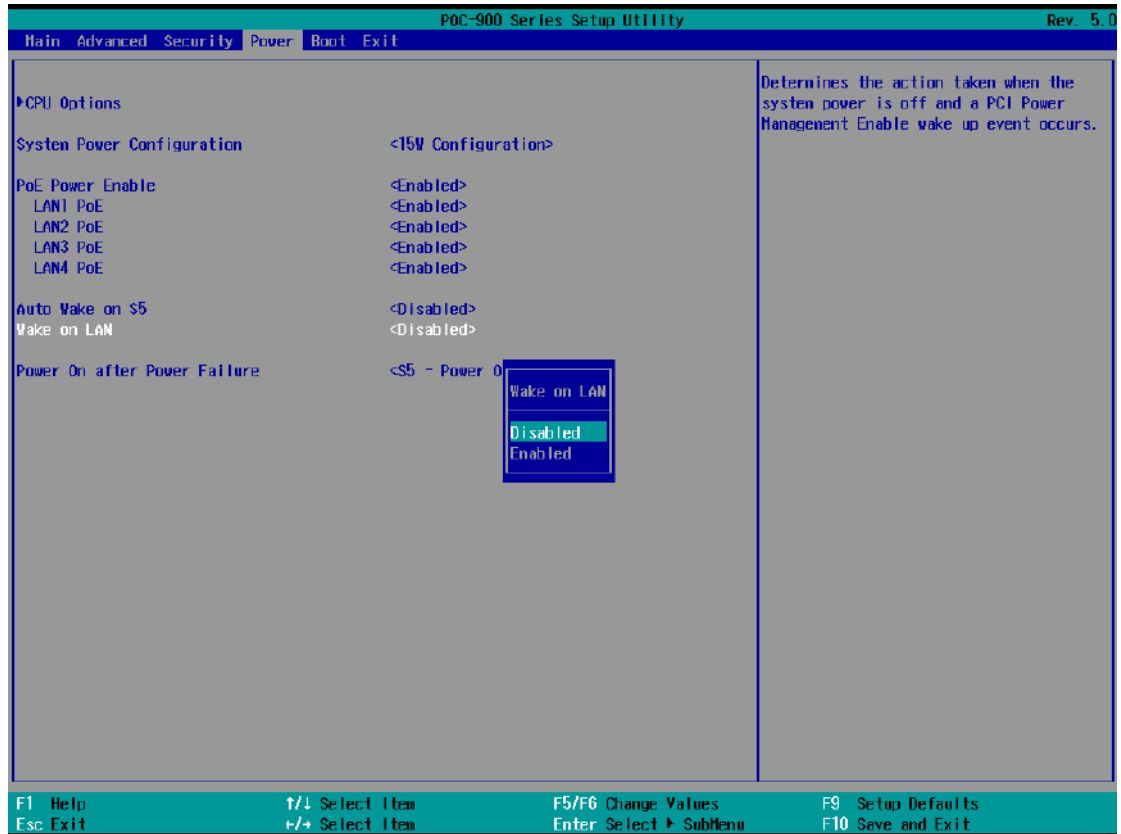

### To enable/disable “Wake on LAN” option:

1. Press **F2** when the system boots up to enter the BIOS setup utility.
2. Go to **[Power]**.
3. You may enable/disable the **[Wake on LAN]** option.
4. Once set, press **F10** to save setting and exit.

## 4.6 Power On after Power Failure

This option defines the system's behavior when DC power is supplied.

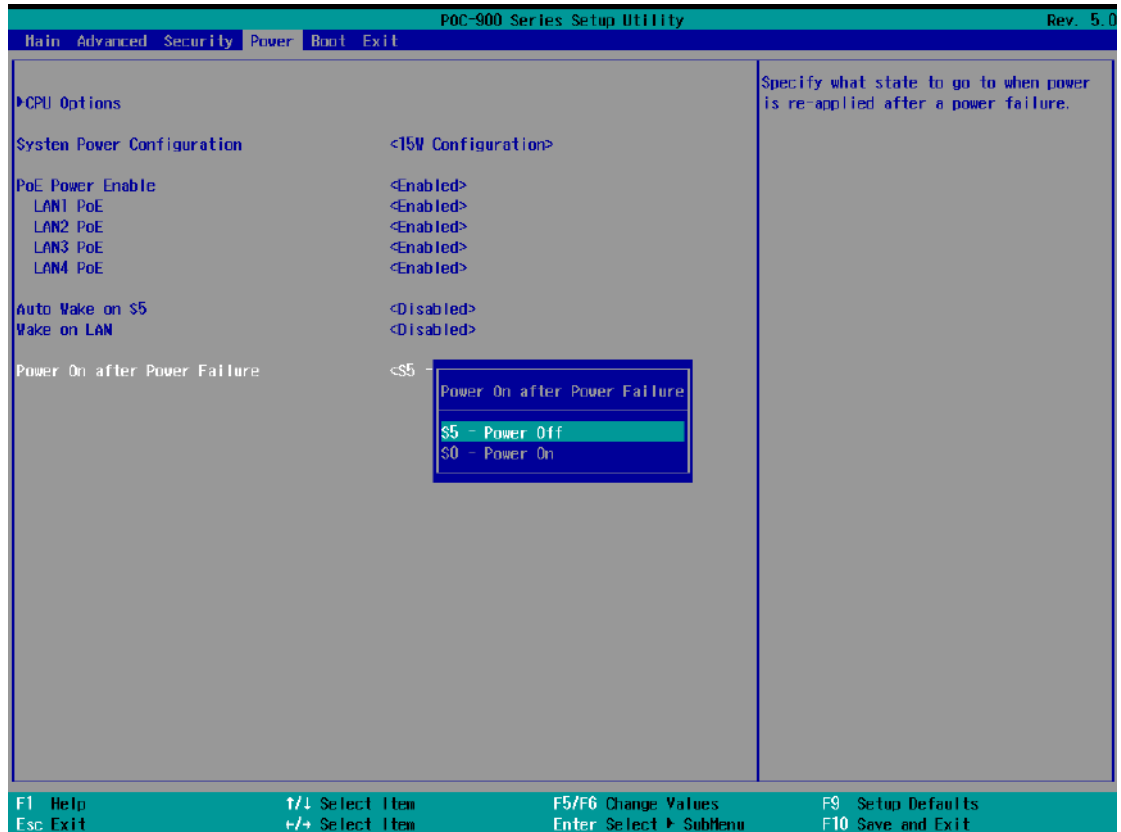

Value	Description
S0 – Power On	System is powered on when DC power is supplied.
S5 – Power Off	System is kept in off state when DC power is supplied.

When you want to use the AT-mode remote on/off control function, you have to set this option to “S0 – Power On”. Please refer to ["Powering On Using An External Latch"](#) for instructions of using AT-mode remote on/off control function.

### To set “Power On after Power Failure” option:

1. Press **F2** when the system boots up to enter the BIOS setup utility.
2. Go to **[Power]**.
3. Set the **[Power On after Power Failure]** option to the desired setting.
4. Once set, press **F10** to save setting and exit.

## 4.7 Boot Menu

The Boot menu in BIOS allows you to specify the system’s boot characteristics by setting bootable device components (boot media) and method. Or, you may press F12 upon system start up and select a device you wish boot from.



Value	Option	Description
Boot Type	UEFI Boot Type	Only UEFI boot media listed are approved as boot media.
Quick Boot	Enabled	The system starts up faster because BIOS skips various hardware function tests
	Disabled	The system starts up slower because BIOS goes through various hardware functions tests
Network Stack	Enabled	The system is available for network access using UEFI.
	Disabled	The system is not available for network access using UEFI.
Add Boot Options	First	Newly detected boot media are placed at the top of the boot order.
	Last	Newly detected boot media are placed at the bottom of the

		boot order.
ACPI Selection	1.0B/ 3.0/ 4.0/ 5.0/ 6..3	Advanced Configuration and Power Interface allows the operating system to control system power management
USB Boot	Enabled	Allow boot from bootable USB devices.
	Disabled	Does not allow boot from bootable USB devices
Timeout	1, 2, 3, etc (in seconds)	Boot delay time in seconds to give the user time to activate the hotkey to access the BIOS
Automatic Failover	Enabled	Automatically checks for the next bootable device when the set default device fails.
	Disabled	Will only boot from the designated device.
<a href="#">WDT for booting</a>	Disabled, 1, 3, 5, 10 (minutes)	WDT ensures a successful system boot by specifying a timeout value
EFI	NA	Extensible Firmware Interface

## 4.8 Position New Boot Device

The “Add Boot Options” allow you to determine whether a newly added device (eg. USB flash disk) is to boot as the first device to boot or the last in the boot sequence.

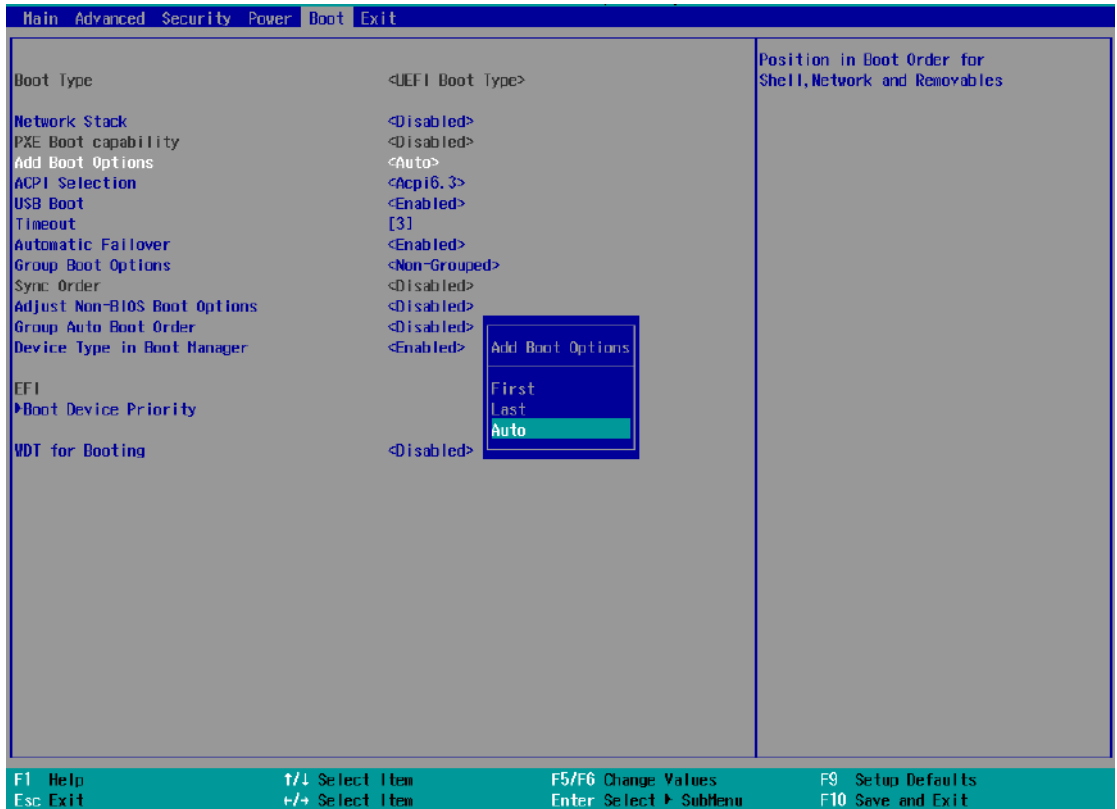

To set the newly-installed boot device as the first or last boot device:

1. Press **F2** when the system boots up to enter the BIOS setup utility.
2. Go to **[Boot] > [Add Boot Options]** menu.
3. Select **[First]** or **[Last]** for your newly-added boot device and press Enter.
4. Once set, press **F10** to save setting and exit.

## 4.9 Watchdog Timer

The watchdog timer secures the boot process by means of a timer. Once the timer expires, a reset command is issued to initiate another booting process. There are two options in BIOS menu, “*Automatically after POST*” and “*Manually after Entering OS*”. When “*Automatically after POST*” is selected, the BIOS automatically stops the watchdog timer after POST (Power-On Self Test) OK. When “*Manually after Entering OS*” is selected, the user must stop the watchdog timer once booted into the OS. This guarantees the system can always boot into the OS, otherwise another booting process will be initiated. For information about programming watchdog timer, please refer to [Appendix A Using WDT & DIO](#).

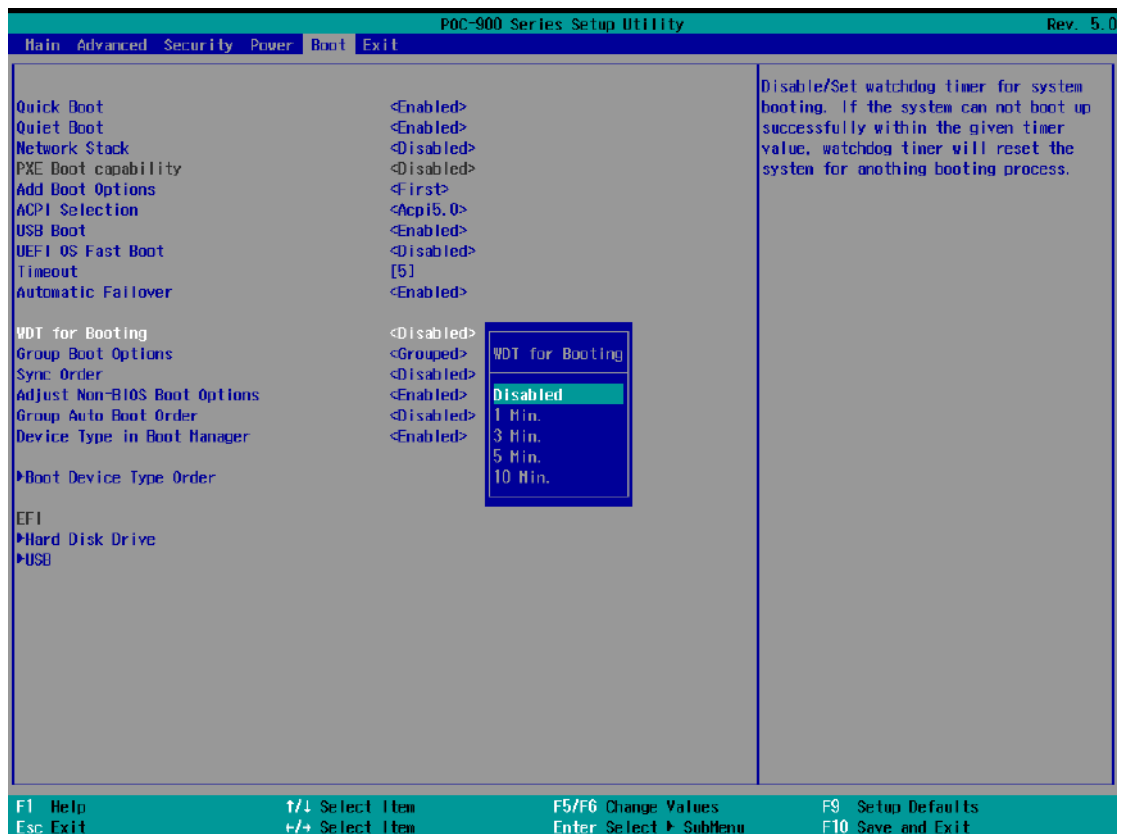

To set the watchdog timer for boot in BIOS:

1. Press **F2** when the system boots up to enter the BIOS setup utility.
2. Go to **[Boot]** menu.
3. Disable or select timeout value for **[WDT for Booting]** option.
4. Once you set a timeout value, the **[WDT Stop Option]** option appears. You can select either “*Automatically after POST*” or “*Manually after Entering OS*”.
5. Once set, press **F10** to save setting and exit.

## 5 OS Support and Driver Installation

### 5.1 Operating System Compatibility

POC-900 series only provide driver support for the following operating systems. The following list contains the operating systems which have been tested in Neosys Technology Inc.

- Microsoft Windows 11 LTSC 24H2
- Ubuntu 22.04.2 LTS or other distribution with kernel version  $\geq 5.19$  \*



#### NOTE

*\*For distributions, graphics driver may not be completely implemented in its kernel. You may encounter restrictions when using these features, such as multiple independent displays. For optimum operation, it is the users' responsibility to manually check for new drivers and upgrades!*

Neosys may remove or update operating system compatibility without prior notice. Please contact us if your operating system of choice is not on the list.

## 5.2 Driver Installation

The system drivers are available online, please click on this [Link](#) to download the drivers.

## 5.3 Driver for Watchdog Timer and DIO

Neosys provides a driver package which contain function APIs for Watchdog Timer control function. You should install the driver package (WDT\_DIO\_Setup.exe) in prior to use these functions. Please download the latest version of WDT\_DIO\_Setup.exe to ensure compatibility.

Please refer to this [Link](#) to download WDT\_DIO.

# Appendix A Using WDT & DIO

The watchdog timer (WDT) function ensures reliable system operation. The WDT is a hardware mechanism to reset the system if the watchdog timer is expired. Users can start the WDT and keeping resetting the timer to make sure the system or program is running. Otherwise, the system shall be reset.

In this section, we'll illustrate how to use the function library provided by Neosys to program the WDT functions. Currently, WDT driver library supports Windows 10 x64 and WOW64 platform. For other OS support, please contact Neosys Technology for further information.

## Installing WDT\_DIO Library

The WDT\_DIO function library is delivered in the form of a setup package named **WDT\_DIO\_Setup.exe**. In prior to program WDT, you should execute the setup program and install the WDT library. Please use the following WDT\_DIO\_Setup packages according to your operating systems and application.

- For Windows 64-bit OS with 64-bit application (x64 mode), please install WDT\_DIO\_Setup\_v2.4.1.0(x64).exe or later versions.



### NOTE

Please download from Neosys website and install the latest WDT\_DIO\_Setup.exe file.

## WDT and DIO Library Installation

To setup WDT & DIO Library, please follow instructions below.

1. Execute **WDT\_DIO\_Setup.2.4.1.0.exe** (or later) and the following dialog may appear. If so, click on "More Info".

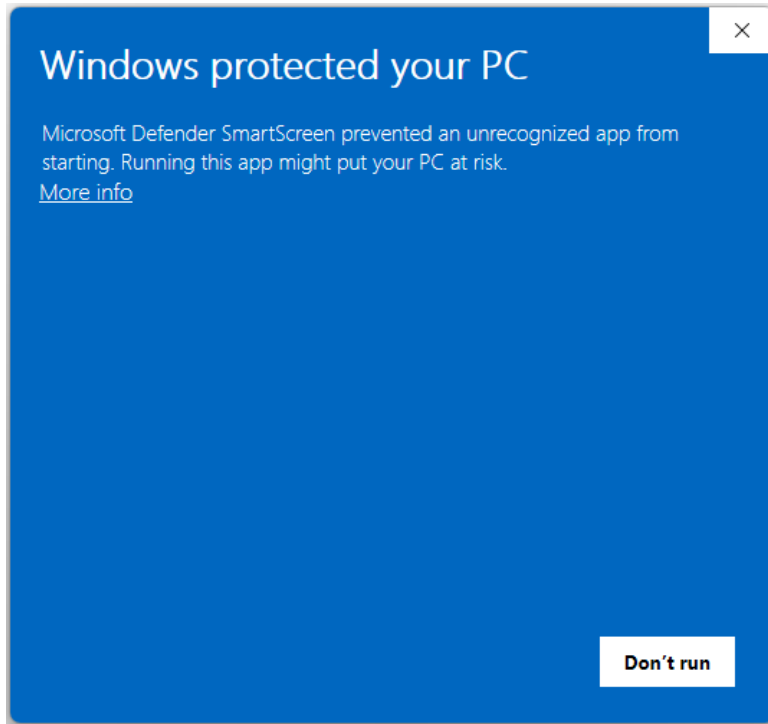

2. Click on "Run anyway" for installation, and click on "Yes" to proceed.

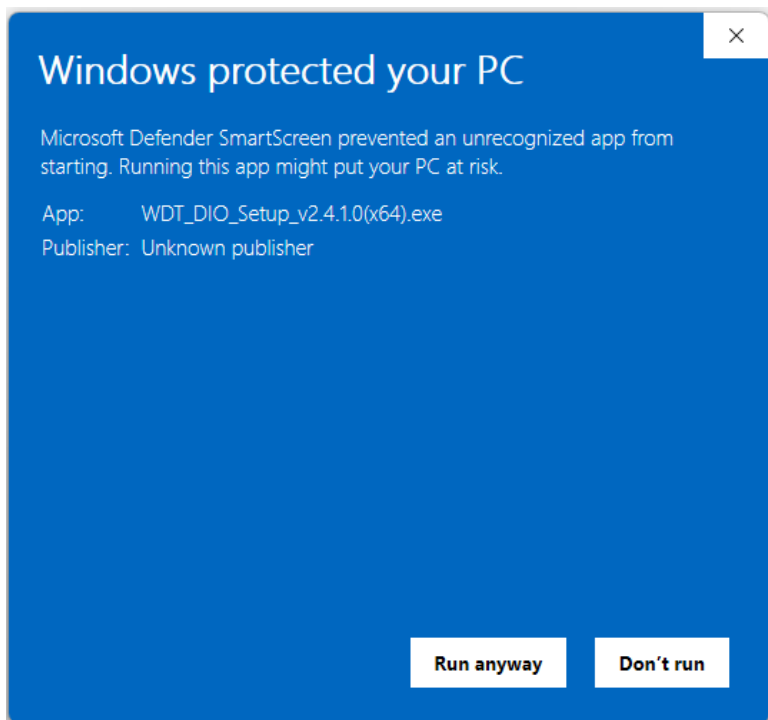

3. Click on Next to begin installation.

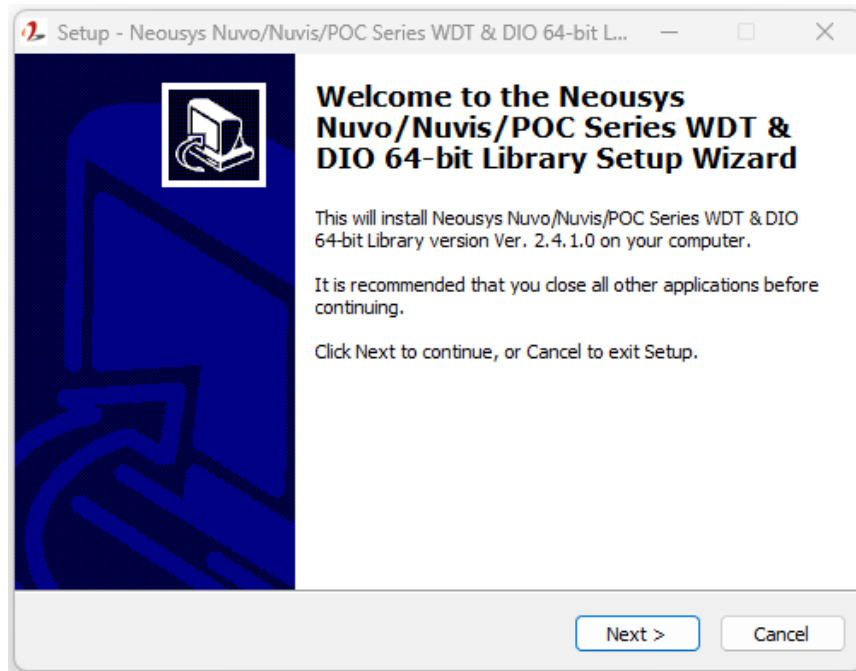

4. Specify the directory you would like to install to, and Click "Next >". The default directory is *C:\Neosys\WDT\_DIO(x64)*.

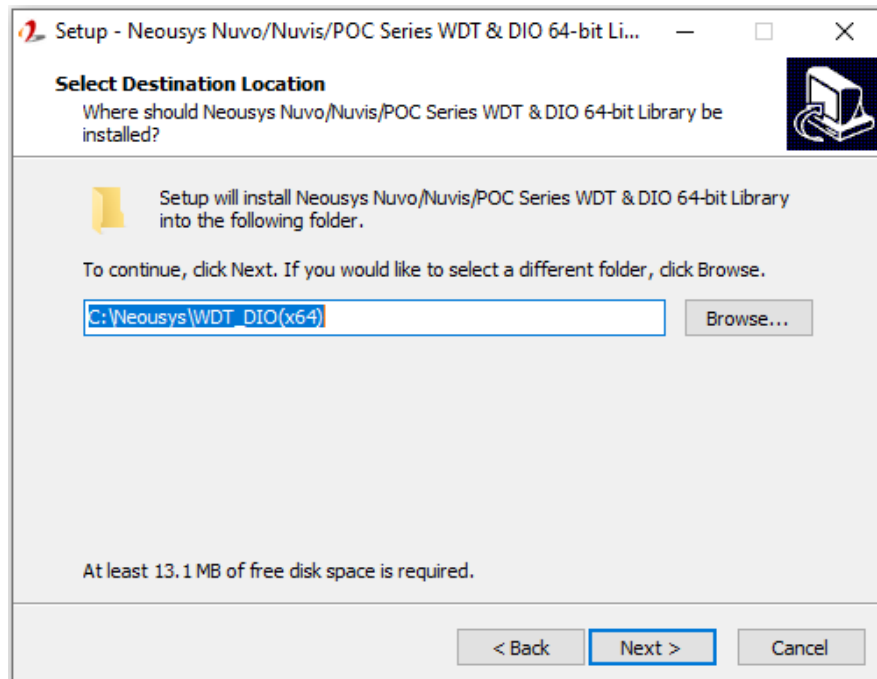

- Once the installation has finished, a dialog will appear to prompt you to reboot the system. The WDT & DIO library will take effect after the system has rebooted.

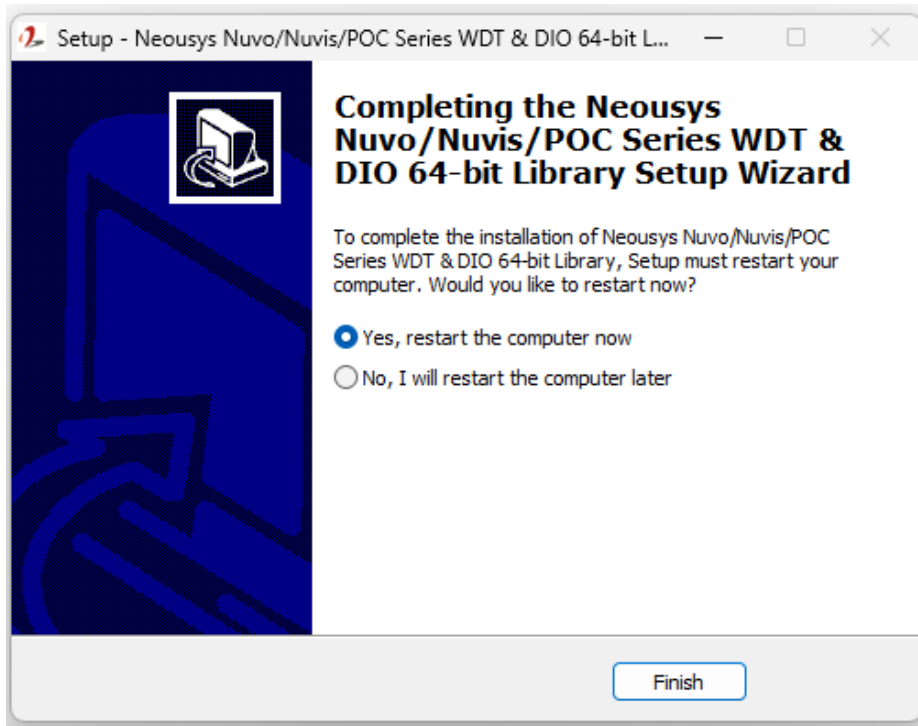

- When programming your WDT or DIO program, the related files are located in

<b>Header File:</b>	\Include
<b>Library File:</b>	\Lib
<b>Function Reference:</b>	\Manual
<b>Sample Code:</b>	\Sample\WDT_Demo (Demo for Watchdog Timer) \Sample\DIO_Demo (Demo for isolated DIO Control) \Sample\COS_Demo (Demo for change-of-state DI)

## WDT Function Reference

### InitWDT

<b>Syntax</b>	BOOL InitWDT(void);
<b>Description:</b>	Initialize the WDT function. You should always invoke InitWDT() before set or start watchdog timer.
<b>Parameter</b>	None
<b>Return Value</b>	<b>TRUE:</b> Successfully initialized <b>FALSE:</b> Failed to initialize
<b>Usage</b>	BOOL bRet = InitWDT()

### SetWDT

<b>Syntax</b>	BOOL SetWDT(WORD tick, BYTE unit);
<b>Description</b>	Set timeout value and unit for watchdog timer. When InitWDT() is invoked, a default timeout value of 255 seconds is assigned.
<b>Parameter</b>	<i>tick</i> WORD value (1 ~ 65535) to indicate timeout ticks. <i>unit</i> BYTE value (0 or 1) to indicate unit of timeout ticks. 0 : unit is minute 1: unit is second
<b>Return Value</b>	If value of unit is correct (0 or 1), this function returns TRUE, otherwise FALSE.
<b>Usage</b>	WORD tick=255; BYTE unit=1; //unit is second. BOOL bRet = SetWDT(tick, unit); //timeout value is 255 seconds

### StartWDT

<b>Syntax</b>	BOOL StartWDT(void);
<b>Description</b>	Starts WDT countdown. Once started, the WDT LED indicator will begin blinking. If ResetWDT() or StopWDT is not invoked before WDT countdowns to 0, the WDT expires and the system resets.
<b>Parameter</b>	None
<b>Return Value</b>	If the timeout value is given in correct format (WDT started), this function returns TRUE, otherwise FALSE
<b>Usage</b>	BOOL bRet = StartWDT()

### ResetWDT

<b>Syntax</b>	BOOL ResetWDT(void);
<b>Description</b>	Reset the timeout value to the value given by SetWDT().If ResetWDT() or StopWDT is not invoked before WDT countdowns to 0, the WDT expires and the system resets.
<b>Parameter</b>	None
<b>Return Value</b>	Always returns TRUE
<b>Usage</b>	BOOL bRet = ResetWDT()

### StopWDT

<b>Syntax</b>	BOOL StopWDT(void);
<b>Description</b>	Stops the countdown of WDT. When WDT has stopped, the WDT LED indicator stops blinking.
<b>Parameter</b>	None
<b>Return Value</b>	Always returns TRUE
<b>Usage</b>	BOOL bRet = StopWDT()

## DIO Functions

### InitDIO

<b>Syntax</b>	BOOL InitDIO(void);
<b>Description</b>	Initialize the DIO function. You should always invoke InitDIO() before write/read any DIO port/channel.
<b>Parameter</b>	None
<b>Return Value</b>	Returns TRUE if initialization successes, FALSE if initialization failed.
<b>Usage</b>	BOOL bRet = InitWDT();

### DIReadLine

<b>Syntax</b>	BOOL DIReadLine(BYTE ch);
<b>Description</b>	Read a single channel of isolated digital input.
<b>Parameter</b>	<b>ch</b> BYTE value specifies the DI channel to be read. <i>Ch</i> should be a value of 0 ~ 3.
<b>Return Value</b>	The status (TRUE or FALSE) of the specified DI channel.
<b>Usage</b>	BYTE ch=3; //DI channel #3  BOOL DIChValue = DIReadLine(ch); //read DI channel #3

### DIReadPort

<b>Syntax</b>	WORD DIReadPort(void);
<b>Description</b>	Read the entire isolated digital input port (4 channels).
<b>Parameter</b>	None
<b>Return Value</b>	A WORD value (0~255) indicates the status of DI port (4 DI channels).
<b>Usage</b>	WORD DIPortValue = DIReadPort ();

### DOWriteLine

<b>Syntax</b>	void DOWriteLine(BYTE ch, BOOL value);
<b>Description</b>	Write a single channel of isolated digital output.
<b>Parameter</b>	<p><b>ch</b>            BYTE value specifies the DO channel to be written. <i>Ch</i> should be a value of 0 ~ 3.</p> <p><b>value</b>            BOOL value (TRUE or FALSE) specifies the status of DO channel.</p>
<b>Return Value</b>	None
<b>Usage</b>	<pre>           BYTE ch=3; //DI channel #3           BOOL DOChValue=TRUE;            DOWriteLine(ch, DOChValue); //write DO channel #3 as           TRUE         </pre>

### DOWritePort

<b>Syntax</b>	void DOWritePort(WORD value);
<b>Description</b>	Write the entire isolated digital output port (4 channels).
<b>Parameter</b>	<p><b>value</b>            WORD value specifies the status of the DO port. <i>Value</i> should be a value of 0~255.</p>
<b>Return Value</b>	None
<b>Usage</b>	<pre>           WORD DOPortValue=0XFF; //11111111b           DOWritePort(DOPortValue); //write DO port as 11111111b         </pre>

# Appendix B PoE On/ Off Control

The system offers two 802.3at PoE+ ports with a unique feature to allow users manually turn on or off the power supply of each PoE port. This can be function can be useful in power device (PD) fault-recovery or power reset.

The function APIs are encapsulated in Neousys WDT\_DIO driver package. Please follow the instructions in [Appendix A Watchdog Timer & Isolated DIO](#) to install the driver package prior to programming PoE on/off control function

## PoE On/ Off Control Function Reference

### GetStatusPoEPort

<b>Syntax</b>	BYTE GetStatusPoEPort (Byte port);
<b>Description</b>	Get current on/off status of designated PoE port.
<b>Parameter</b>	<i>port</i>  BYTE value specifies the index of PoE port. Please refer to the following illustration, <i>port</i> should be a value of 1 - 4.
<b>Return Value</b>	BYTE value indicating PoE on/off status  0 if port is disabled (off)  1 if port is enabled (on)
<b>Usage</b>	BYTE bEnabled = GetStatusPoEPort (1); //Get on/off status of PoE Port#1

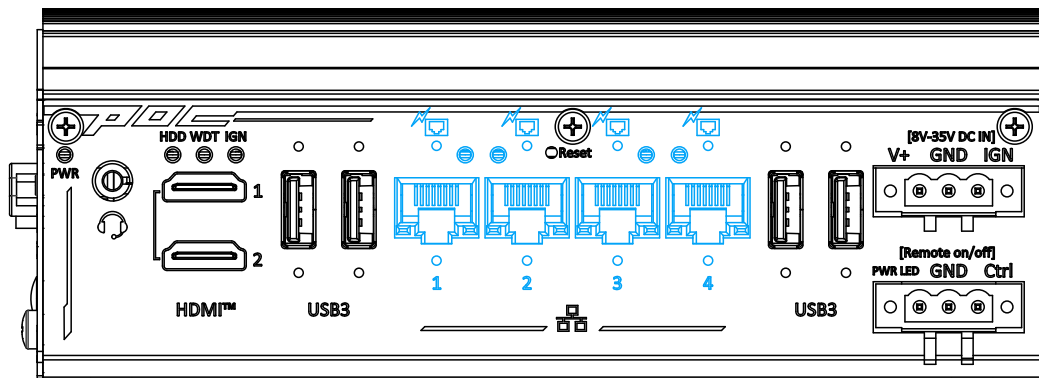

### EnablePoEPort

<b>Syntax</b>	BOOL EnablePoEPort (BYTE port);
<b>Description</b>	Turn on PoE power of designated PoE port.
<b>Parameter</b>	<p><i>port</i></p> <p>BYTE value specifies the index of PoE port. Please refer to the following illustration, <i>port</i> should be a value of 1 - 4</p>
<b>Return Value</b>	<p><b>TRUE</b> if enabled success</p> <p><b>FALSE</b> if fail to enable.</p>
<b>Usage</b>	BOOL bRet = EnablePoEPort (1); //Turn on PoE Port#1

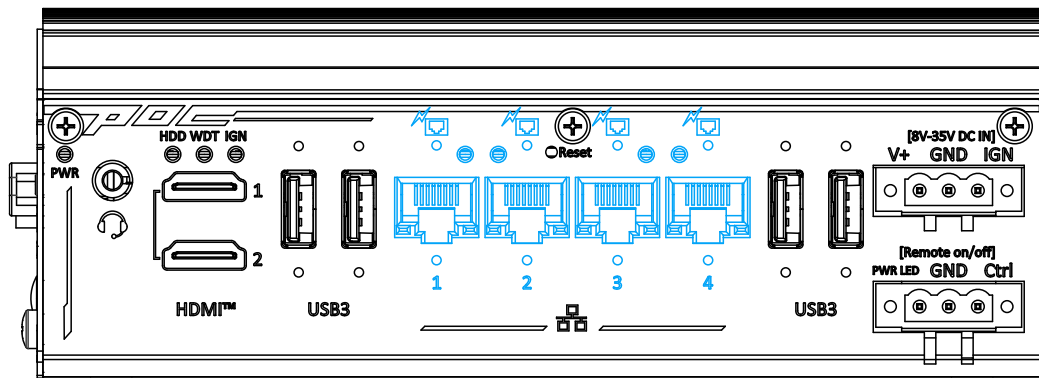

### DisablePoEPort

<b>Syntax</b>	BOOL DisablePoEPort (BYTE port);
<b>Description</b>	Turn off PoE power of designated PoE port
<b>Parameter</b>	<i>port</i>  BYTE value specifies the index of PoE port. Please refer to the following illustration, <i>port</i> should be a value of 1 - 4
<b>Return Value</b>	<b>TRUE</b> if disabled success  <b>FALSE</b> if fail to disable
<b>Usage</b>	BOOL bRet = DisablePoEPort (1); //Turn off PoE Port#1

