

Manual

**NB-IoT**

**People Counter**

---

IMBuildings B.V.

2020

v1.1 (initial release)

## Preface

**Note:** This document is shared by IMBUILDINGS B.V. for the purpose of transferring knowledge only to our customers and/or partners.

This documented is not to be distributed by any other than IMBUILDINGS B.V.

## Revision history

Version, Date, Author(s)	Changes
v1.1 24-01-2022 M. Spijker	Preliminary release

# Index

<b>Preface</b>	<b>1</b>
Revision history	1
<b>Index</b>	<b>2</b>
<b>About IMBUILDINGS™</b>	<b>4</b>
<b>Safety instructions</b>	<b>5</b>
<b>1. Product introduction</b>	<b>6</b>
1.2 Principle of work	6
1.3 Communication	6
1.4 Specifications	6
<b>2. Configurable settings</b>	<b>9</b>
3. Contents of delivery	11
4. Installation Tools	11
5. Accessories	12
<b>6. Installation</b>	<b>14</b>
6.1 Handling the housing	14
6.2 Count directions	16
6.3 Mount the People Counter	16
6.4 Additional information	17
6.5 ENI (Enhanced Noise Immunity)	17
<b>7. Power on</b>	<b>18</b>
7.1 IR Transmitter	18
7.2 IR Receiver	19
7.2.1 Power On:	19
7.2.2 Validation mode	20
7.2.3 Counting mode	20
7.3 Alignment mode	20
7.4 Accuracy of the People Counter	20
<b>8. Ordering information</b>	<b>21</b>
8.1 People Counter sets	21
8.2 People Counter parts	21
8.3 Accessories	21

<b>9. Related information</b>	<b>22</b>
IMBUILDINGS	22
<b>Caring for the environment by recycling.</b>	<b>22</b>
<b>Disclaimer</b>	<b>22</b>
<b>Notes</b>	<b>23</b>

## About IMBUILDINGS™

The focus for IMBUILDINGS is the Smart Building market. Within this market there is a growing need for sensor products.

Customers of IMBUILDINGS are mainly System Integrators who integrate the hardware products within their total solution. These solutions are for example IoT platforms for Facility Management, Building Monitoring, Healthy Schools and so on.

A complete range of sensing products using a variety of connectivity technologies are offered.

We see our customers as partners. Together with our partners a complete range of solutions can be offered with the needs within the market.

**Sensor Development International:** Research and Development company which is focusing on the development of sensor based products. Developed products are also placed into the market by Sensor Development International for the brand IMMOTION®

For IMBUILDINGS a more open product range is required. The development for these demands are executed by Sensor Development International. For example, implementing standardized communication protocols and implementing open data formats.

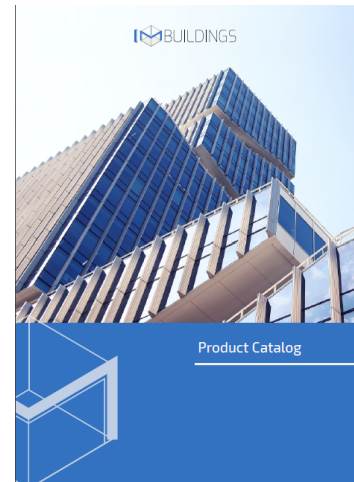

## Safety instructions

To avoid damage or malfunction, please take the following into consideration.

- Do not expose to water,moisture,and conductive surfaces.
- Do not expose to heat from any source, the product is designed to work under normal ambient temperatures.
- Take care when handling the device,to prevent damage to the mechanical or electrical components.
- Avoid handling the circuit board while the device is powered, to minimize the chance of electrostatic damage.

Ambient operating temperature	0-40°C at 0-95% non condensing humidity.
Nominal Voltage	3V
Power supply	2x AA 1,5v lithium batteries*
Maximum power consumption	60mA

\*The manufacturer's instructions for the respective batteries need to be observed

The capabilities,system requirements and / or compatibility with third party products described herein are subject to change without notice.

# 1. Product introduction

The NB-IoT People Counter is a battery powered sensor for counting people crossing a horizontal line. The counter consists of two parts, an infrared (IR) transmitter part and an infrared receiver part, which always work together.



The IR transmitter transmits the infrared signal.

The IR receiver is the main part and holds the intelligence and communication with the outside world.

## 1.2 Principle of work

The IR transmitter device points the IR beam horizontal towards the IR receiver part at a recommended height. When this beam is interrupted, the algorithm in the IR receiver part determines if this was a person and determines the direction A or B.

## 1.3 Communication

The created data is communicated from the internal algorithm microprocessor to the internal gateway microprocessor. The internal gateway processor communicates this information to the internal NB-IoT module which takes care of the communication with the NB-IoT network.

Settings for the NB-IoT interface are done via NFC memory.

## 1.4 Specifications

For the main technical specification please refer to the product sheet.

Technical specifications	
Single operation voltage	Nominal 3.0V
Power supply	2x AA 1,5v lithium batteries
Protection degree	IP20





Image: IR Receiver part

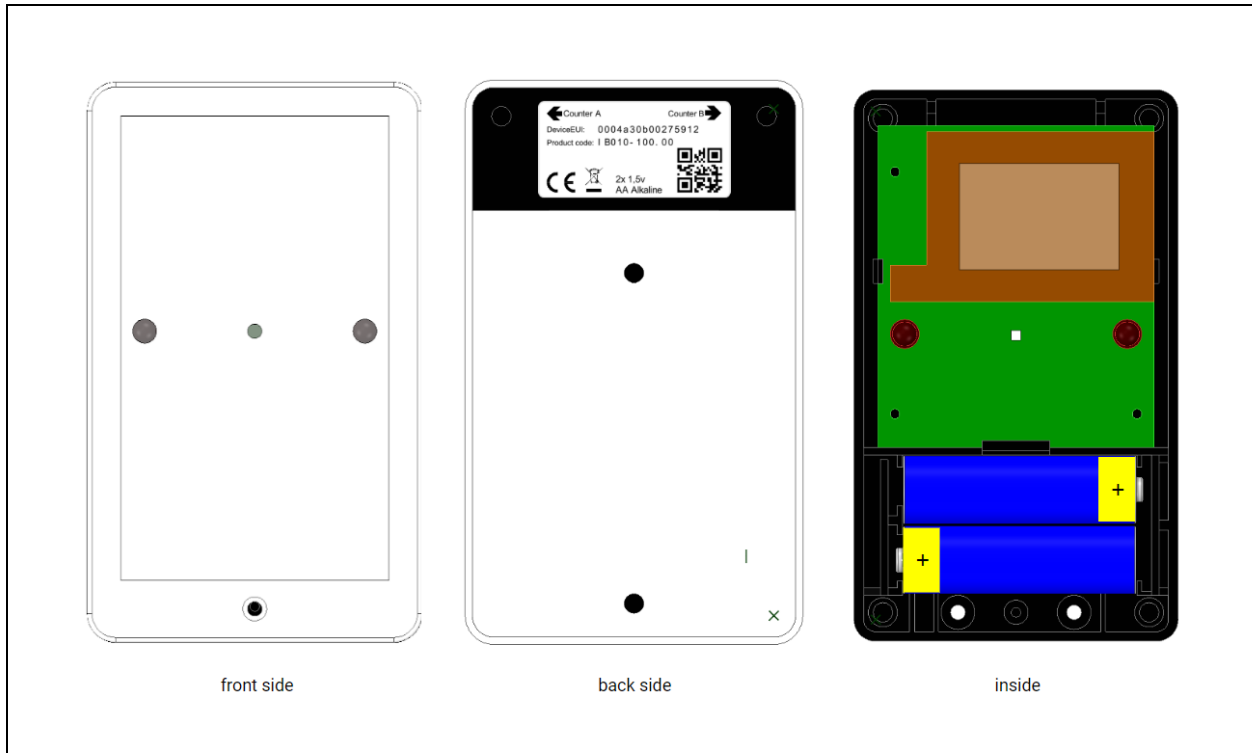
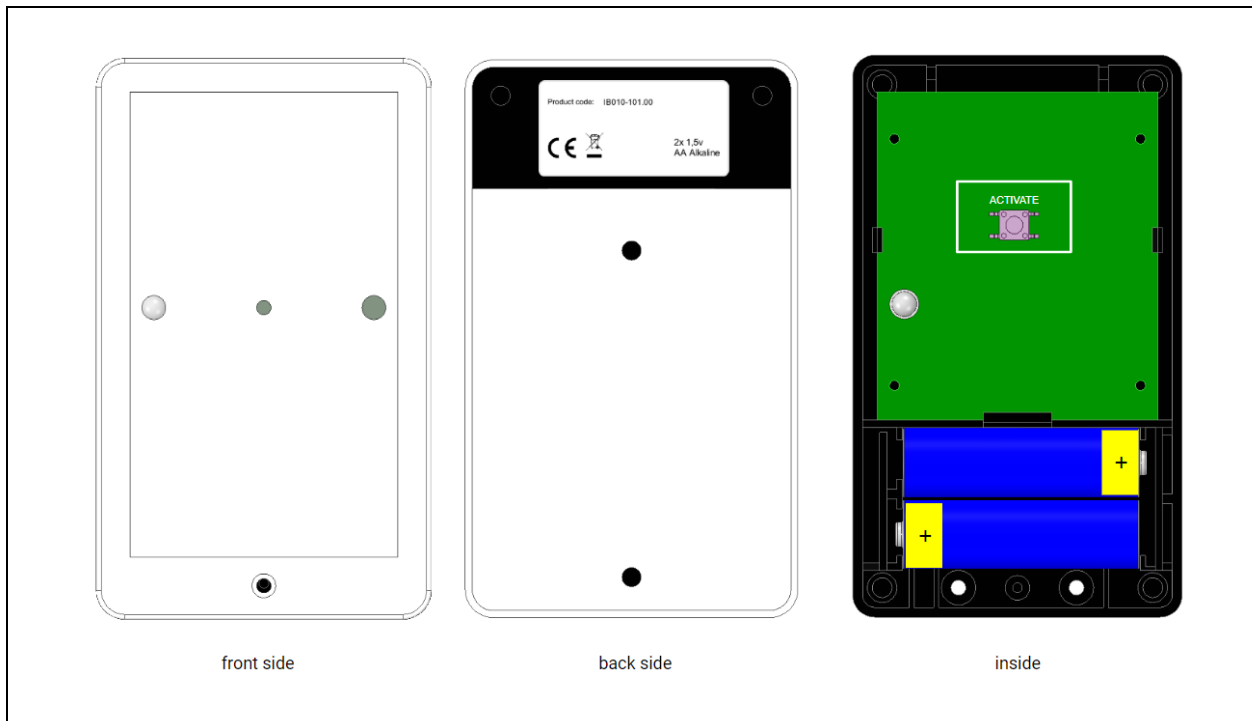

Image: IR Transmitter part



\*batteries shown in the picture are not included. a black sliding bracket on the back side may also be used

## 2. Configurable settings

The table below shows the settings which can be configured using the NFC Memory.

**Table 1:**

Setting	Info	Default Value EU868
Send interval	1 to 240 minutes	15 minutes
Confirmed message	On, Off or first 2	off
Event enable	Yes,No	No
Event Count	1 to 200	1
Event Timeout	1 to 200	1
Enable payload metadata	Yes,No	Yes
Payload type	Refer to the integrator guide for all options	2
Payload variation	Refer to the integrator guide for all options	6
Heartbeat enable	enable a heartbeat from the counter	OFF
heartbeat port	1 to 223	2
heartbeat payload type	Refer to the integrator guide for all options	2
heartbeat payload variant	Refer to the integrator guide for all options	6
heartbeat interval	1 to 240 minutes	60
APN	Provider APN information	-
Operator	Provider operator information	-
NB-IoT Band	Provider band information	-
UDP Listen Port	Source port	7000
Destination Server	IP address of the server	-
Destination Port	Port of the server	-

These settings may have influence on the working of the device.

To set up the device an Android device/phone with NFC is required. For our partners we have an App available.

### 3. Contents of delivery

When the product is ordered it will be shipped in a bulk package.

Contents of a single NB-IoT People Counter set

- NB-IoT People Counter Rx (IR receiver part)
- People Counter Tx (IR transmitter Part)

Both, IR receiver and IR transmitter, includes a white front cover and a sliding bracket and 2x a screw to close the front cover.

Note: Alkaline batteries are not included.

A NB-IoT People Counter set needs 4x AA 1.5V Batteries. Both, IR receiver and IR transmitter, need 2x AA 1.5V Alkaline batteries.

### 4. Installation Tools

For installing this product only a few simple tools are required.

Task	Tool
Determine installation height	Measurement tape
Mount the People Counter	Scissors and double sided tape or screws and a drill / screwdriver
Enable validation mode	Magnet*
Close the front cover	Screwdriver*
Device configuration	Android device with NFC

\* available as accessory

## 5. Accessories

The product comes in bulk packaging without accessories.

There are several accessories available.

Brackets, screwdriver (for closing front cover), magnet (for enabling validation mode)

You are allowed to use and make your own accessories. In case there is a request for a special accessory like a specific bracket we will look into the possibilities to manufacture this and add it to our portfolio.

For outdoor/public use we have robust housing available. As shown in the picture below the People Counter will fit in this robust housing.

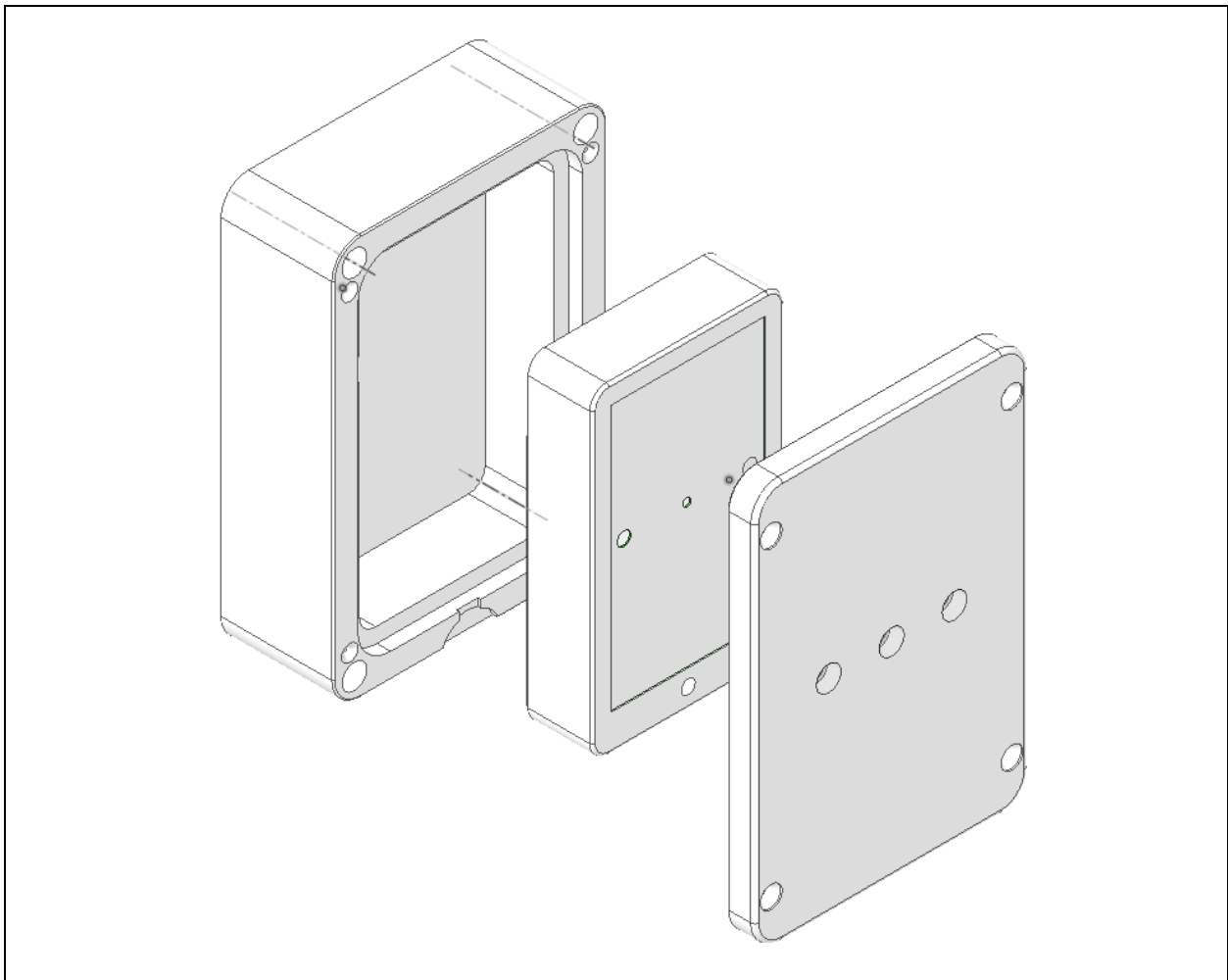

**Plexiglass corner bracket**

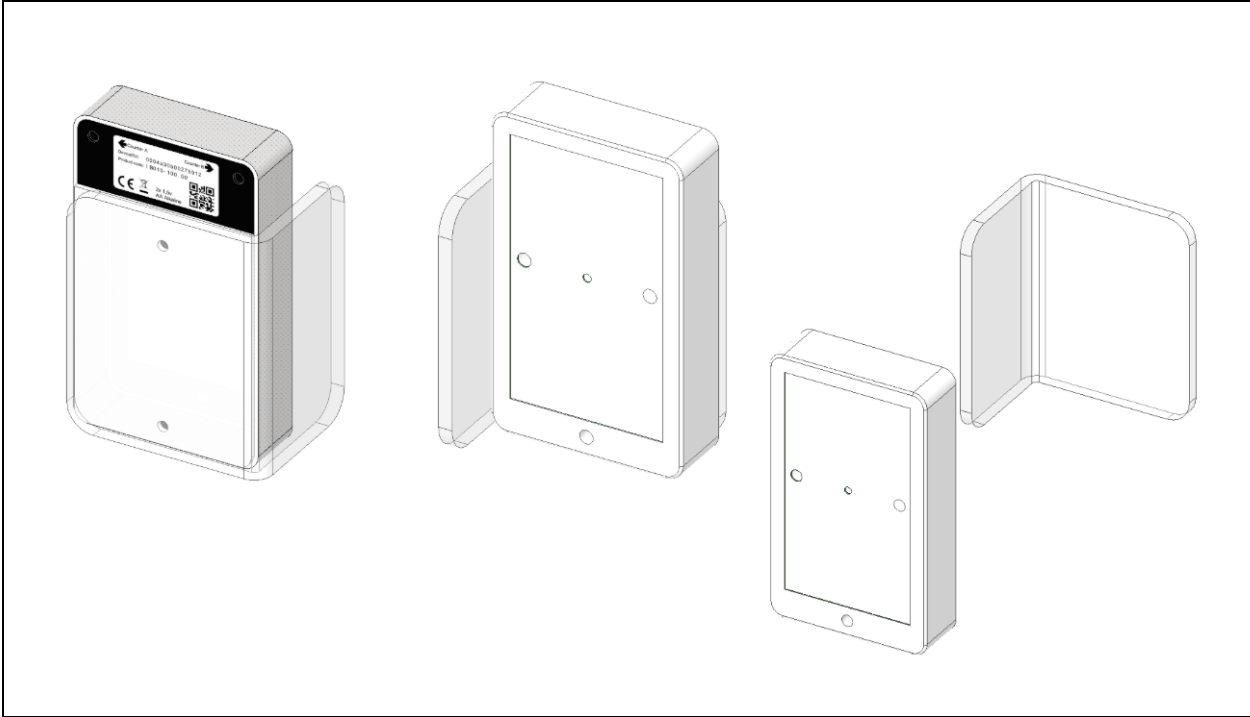

**Rotation bracket**

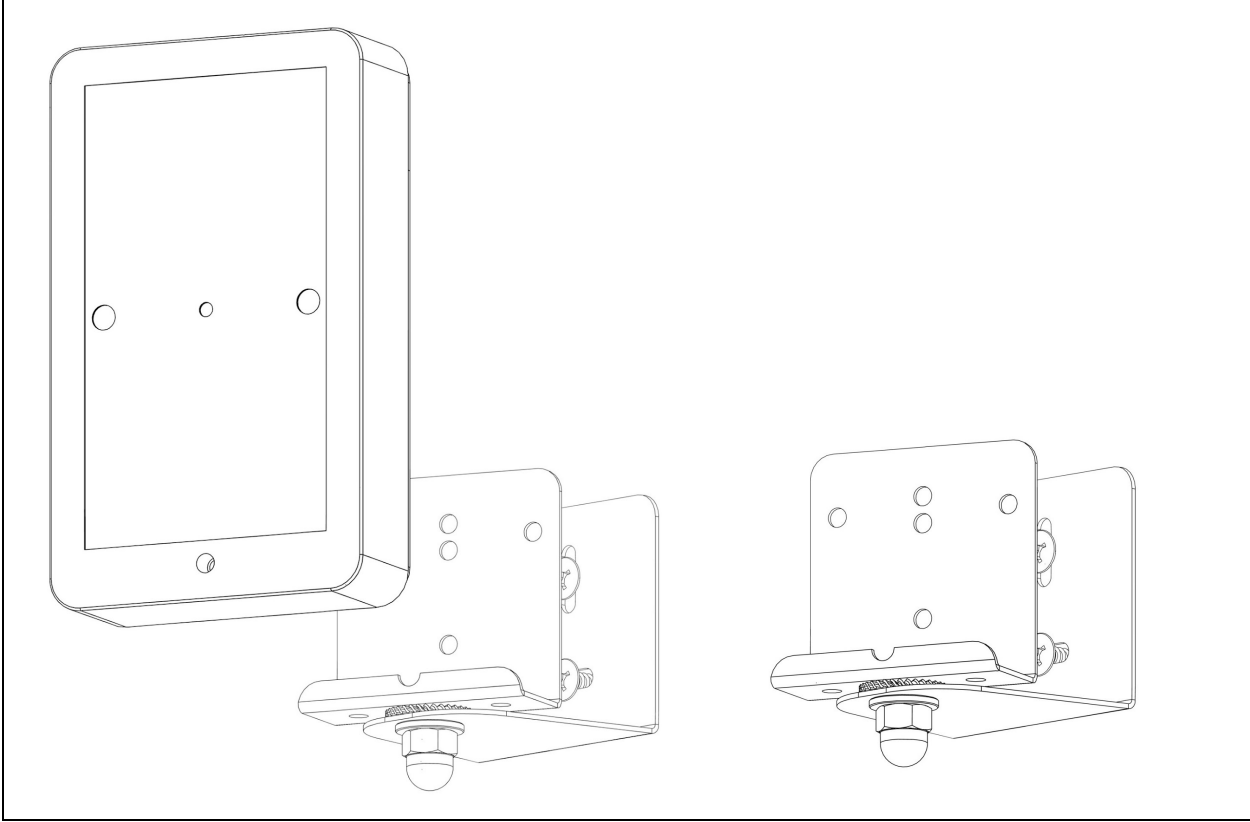

## 6. Installation

Before installing the device physically on the desired location we recommend setting up the NB-IoT settings in advance. This includes the setup needed within your software platform.

And placing the Sim Cards in the devices.

Always be aware where which device is placed. Each device has an IMEI which can be used as a reference.

### 6.1 Handling the housing

**Image: Removing the front cover**

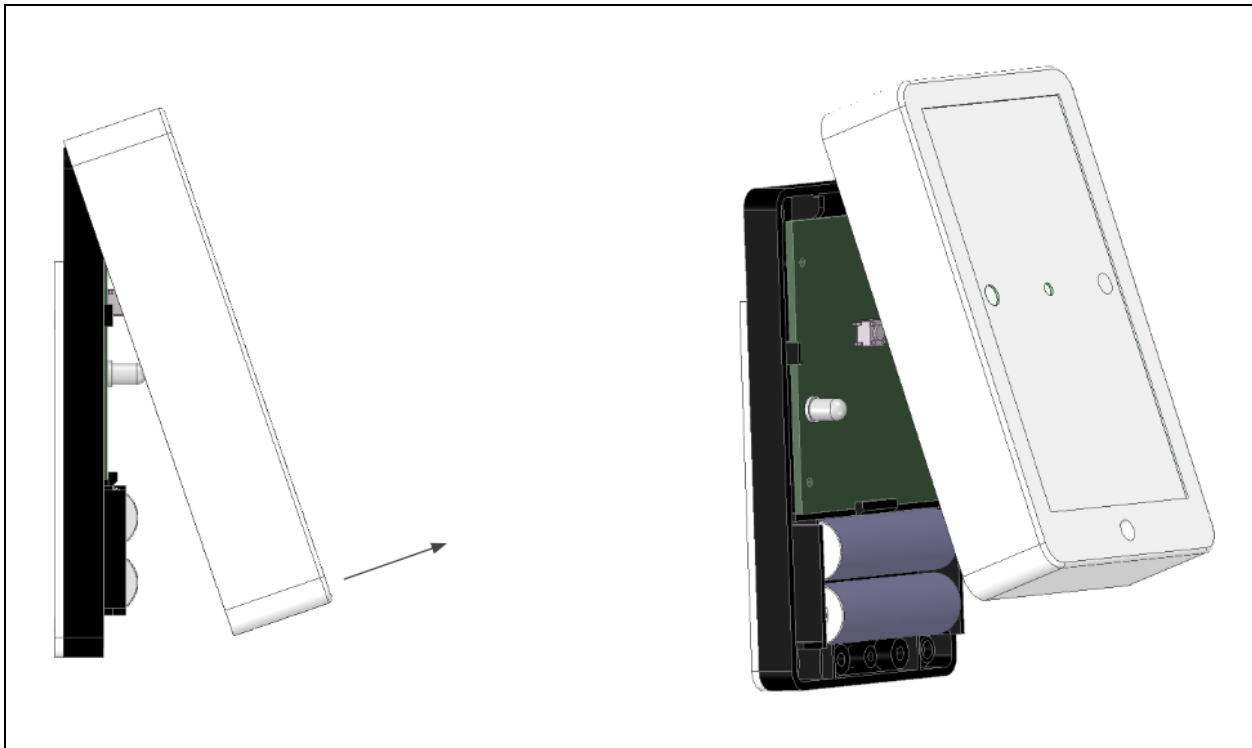
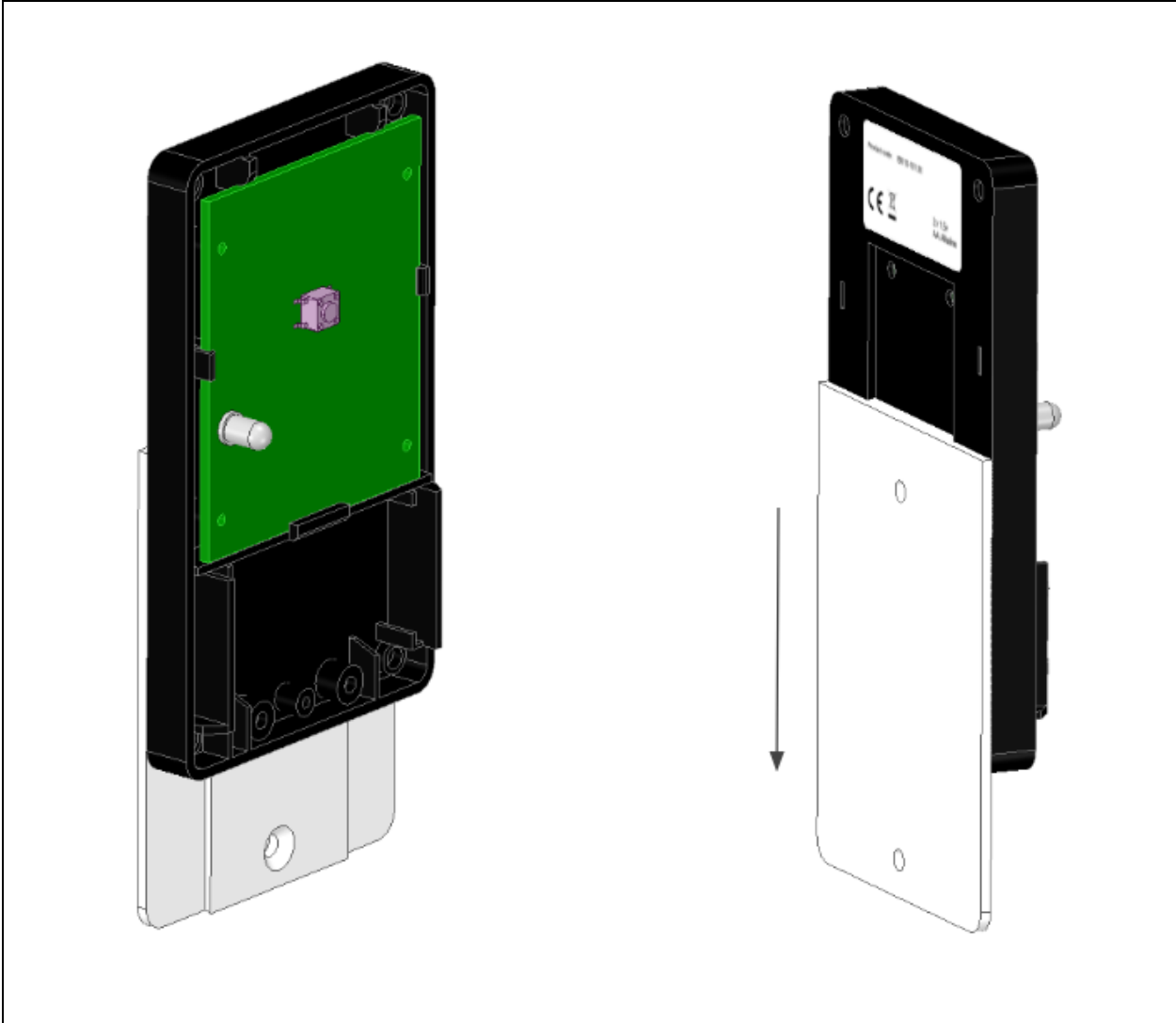

Image: Using the included bracket





## 6.2 Count directions

The NB-IoT People Counter counts bi-directional, described as Counter A (In) and Counter B (Out). Please check the sticker on the backside to view these count directions.



## 6.3 Mounting the People Counter

When mounting the People Counter take care of the following:

- The maximum distance between the transmitter (Tx) and receiver (Rx) is 8 meter.
- To count adults we recommend to use a mounting height between 125cm and 140cm.
- Use a wall or another steady object to mount the People Counter on.

## 6.4 Additional information

The maximum measurement width of 8 meter will decrease when the infrared signal goes through glass or when full sunlight is shining directly into the receiver at a low angle.

## 6.5 ENI (Enhanced Noise Immunity)

The NB-lot People Counter is featured with ENI. The ENI uses DSP technology to filter out disturbances received from the environment like AM anti-shoplifting systems and pulsating infrared sources.

In case there is too much noise received, the red led will light up. In this case, find the cause of the disturbance and try to take it away.

## 7. Power on

### 7.1 IR Transmitter

Place the batteries into the IR transmitter to power on the device.

To activate the IR Transmitter press and release the small Activation Button. The status LED will blink **RED** twice during activation.

**Image: IR Transmitter inside**

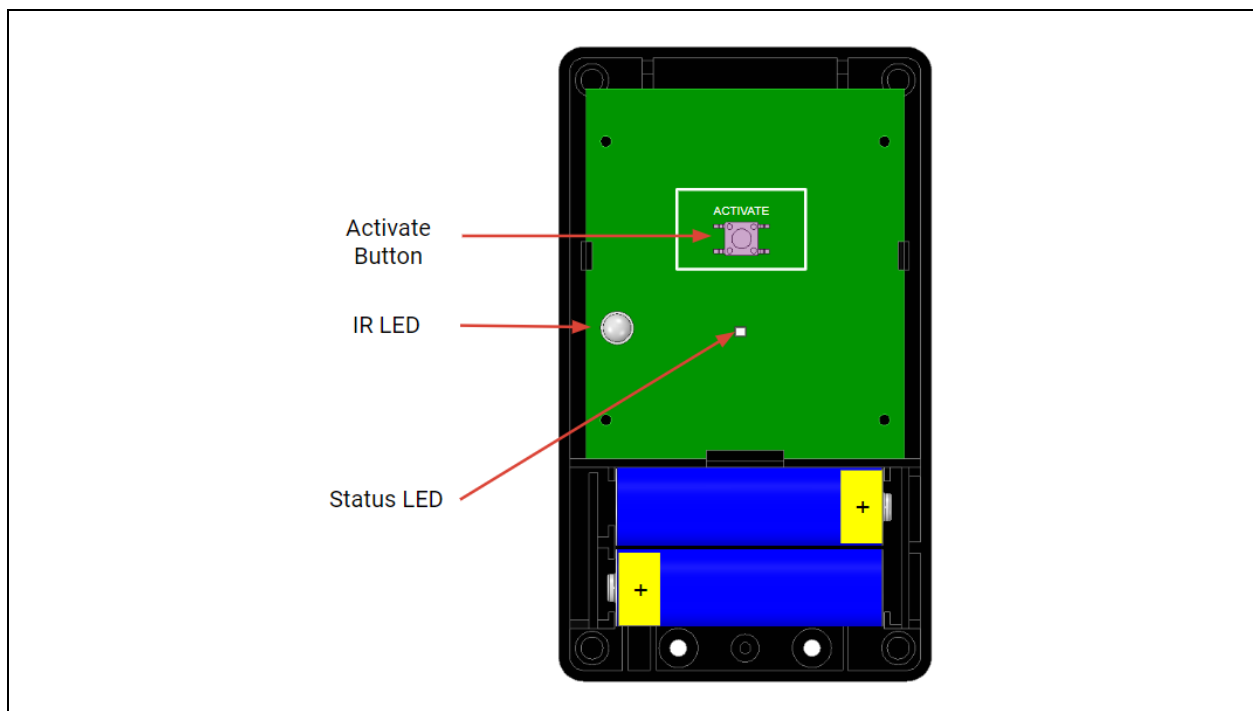

## 7.2 IR Receiver

When placing the batteries in the IR receiver the device will guide through the installation procedure.

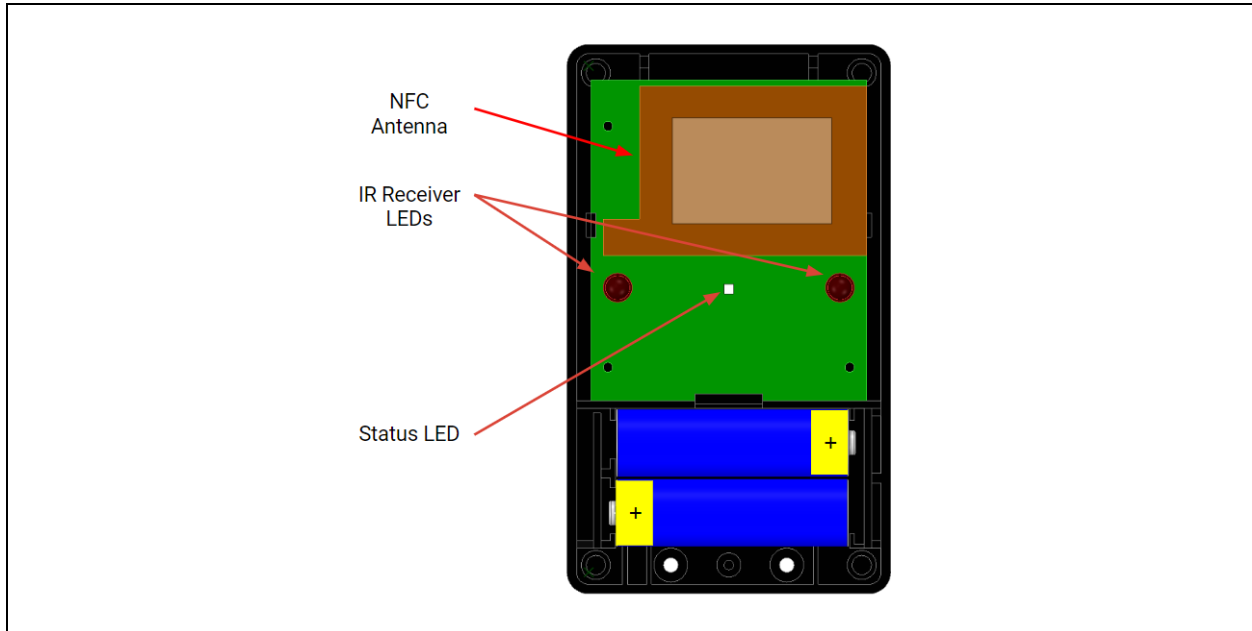

Please read the following about this procedure

### 7.2.1 Power On:

LED blinks orange	Battery voltage too low. Cause: empty batteries or rechargeable batteries placed. <b>The device halts here</b>
LED is orange for 2 seconds	used batteries are detected at power up
LED is blue	No or incomplete settings. <b>The device halts here</b>
LED is blinking blue	Building connection with the LoRaWAN network
LED is green for 2 seconds	Connected. Device is now in validation mode

## 7.2.2 Validation mode

This mode is active for 2 minutes.

*You can enter this mode anytime by sliding a magnet over the magnet area. When using the magnet the device will first go into alignment mode for 1 minute before entering the validation mode.*

Within the validation mode the led will **blink green** when a count is registered. Please make some counts.

**Note:** In case you don't see a green blink please check the alignment of the People Counter first. This is described in the next chapter 'Alignment mode'

When the validation mode is ending the **blue led will blink** indicating the first validation counts are sent away over the NB-IoT connection.

At this moment we recommend checking if the data was received by your software platform.

## 7.2.3 Counting mode

Within this mode the device will not show any LED information.

Once every X\* minutes the data is sent using the NB-IoT connection. This interval was set during the configuration of the device using NFC.

\*X indicates the interval set in the device

## 7.3 Alignment mode

To have accurate counting the receiver needs to 'see' (be in alignment with) the IR transmitter.

The IR receiver contains an alignment mode which helps to point the IR transmitter to the IR receiver. To enable the alignment mode slide the magnet on the top of the IR receiver [magnet area]. When the led is blinking **RED** you need to point the IR transmitter to the IR receiver until the led lights up **GREEN** continuously.

Please try to find the middle of the infrared light beam during the alignment.

## 7.4 Accuracy of the People Counter

The accuracy of the People Counter will be higher when the distance between the IR transmitter and IR receiver gets smaller. When multiple people interrupt the infrared beam at once the People Counter will increase the count value by one.

## 8. Ordering information

All items do have a product code. These codes are on the back side of the product.

Below a list of related products and their product codes:

### 8.1 People Counter sets

Product code	Product name
IB011-001.00	NB-IoT People Counter set White <b>Contains: IB010-001.00, IB010-101.00</b>
IB011-001.02	NB-IoT People Counter set Black <b>Contains: IB011-100.02, IB010-101.00</b>

### 8.2 People Counter parts

Product code	Product name
IB011-001.00	NB-IoT People Counter Rx White <b>IR Receiver part</b>
IB011-100.02	NB-IoT People Counter Rx Black <b>IR Receiver part</b>
IB010-101.00	People Counter Tx <b>IR Transmitter part</b>

### 8.3 Accessories

Product code	Product name
IB001-003.00	Alkaline battery 1.5V (4pcs)
IB001-002.00	Lithium battery 1.5V (4pcs)
IB001-004.00	Magnet key hanger
IB001-005.00	Screw driver (small)

IB002-002.00	People Counter robust housing (2pcs)
--------------	--------------------------------------

## 9. Related information

Additional Documentation is available.  
Please reference our system integrator guide for integration information.

### Caring for the environment by recycling.

Do not dispose of the product with residential or commercial waste.  
IMBuildings B.V. will take care of the correct way of recycling the product.  
For more information contact IMBuildings B.V.

Please recycle product packaging and this document.

### Disclaimer

IMBUILDINGS has taken reasonable measures to provide information in this manual that is complete and accurate, however IMBUILDINGS reserves the right to change any information and/or specification without prior notice.

This guide is produced by the manufacturer in the English language. Operators may elect to translate the guide.

any translated version of the guide is created purely for the convenience of the operator and end user, and the english language version is controlling and shall prevail.

IMBUILDINGS hereby disclaims all liability for any translated versions of this guide created by an operator, for but not limited to, the content of any translated guide, the accuracy of the translation and any issues arising as a result of the translated guide, whether they be of an end user nature, legal nature or otherwise.

## Notes

A large, empty rectangular box with a thin blue border, intended for taking notes. It occupies most of the page below the 'Notes' header.





**IMBUILDINGS B.V.**

Noordwijk 49  
7751AH Dalen  
The Netherlands

+31 524 551454

[info@imbuildings.com](mailto:info@imbuildings.com)

[www.imbuildings.com](http://www.imbuildings.com)

