



## Package Content



RAK7200 device  
(1x)



Micro USB cable  
(1x)

## Product Description

The RAK7200 is a GPS tracker with LoRaWAN functionality. It comes with an Li-Ion battery inside the casing, an a convenient rubber belt for quick mounting.

It is built around the low power LoRa module, which integrates an ultra-low power STM32L073 microcontroller and an SX1276 LoRa long range modem. Additionally, there is the Sony CXD5603GF GPS radio on board.

This LoRa node is perfect for IoT applications such as asset tracking, smart vehicle management and location-based services. You need only flash the latest firmware and do a quick configuration setup via the AT commands in order to make it a part of your LoRaWAN network. With the RAK7200 you get a fully functioning GPS tracker, with low power consumption and the great range that LoRa provides.

## Product Features

- Built-in digital output motion sensor LIS3DH, which has dynamic user selectable full scales of  $\pm 2g/\pm 4g/\pm 8g/\pm 18g$  and it is capable of measuring accelerations with output data rates from 1Hz to 5kHz
- Integrated 9-axis sensor - includes a triple-axis gyroscope, a triple-axis accelerometer, and a triple-axis magnetometer.
- LoRaWAN 1.0.2 protocol stack – OTAA and ABP modes.
- LoRa and GPS antennas are integrated inside the casing.
- Low-power mode cycling.
- Micro USB – configuration and battery charging
- LoRa Bands: EU868, US915, AS923, AU915, KR920, IN865.





## Key Features:

<b>Computing</b>	<ul style="list-style-type: none"> <li>Low power LoRa module, built-in the ultra low power ARM Cortex-M3 STM32L073 microcontroller</li> </ul>
<b>LoRa Module</b>	<ul style="list-style-type: none"> <li>Built-in SX1276 LoRa module</li> </ul>
<b>GPS Module</b>	<ul style="list-style-type: none"> <li>Built-in CXD5603GF GPS modem</li> </ul>
<b>Sensors</b>	<ul style="list-style-type: none"> <li>LIS3DH: digital output motion sensor</li> <li>9-axis sensor: include the triple-axis gyroscope and the triple-axis accelerometer and the triple-axis magnetometer</li> </ul>
<b>Frequency</b>	<ul style="list-style-type: none"> <li>EU868, US915, AS923</li> <li>AU915, KR920, IN865</li> </ul>
<b>LoRaWAN Version</b>	<ul style="list-style-type: none"> <li>LoRaWAN Version: V1.0.2</li> <li>Semtech SX1301 Driver Version: V5.0.1</li> <li>Packet Forwarder Version: V4.0.1</li> </ul>
<b>Activation Way</b>	<ul style="list-style-type: none"> <li>ABP and OTAA</li> </ul>
<b>Transmitting</b>	<ul style="list-style-type: none"> <li>20dBm (Max)</li> </ul>
<b>Receiving</b>	<ul style="list-style-type: none"> <li>-130dBm (Min)</li> </ul>
<b>Peripheral Interface</b>	<ul style="list-style-type: none"> <li>Micro USB</li> </ul>
<b>LED</b>	<ul style="list-style-type: none"> <li>LED1 – indicates the Li-ion Battery is charging.</li> <li>LED2 – indicates the Li-ion Battery is full charge.</li> <li>LED3 – indicates the device is sending data.</li> </ul>
<b>Antenna</b>	<ul style="list-style-type: none"> <li>Built-in LoRa and GPS Antenna</li> </ul>
<b>Power Consumption</b>	<ul style="list-style-type: none"> <li>Normal Mode: Tx@20dB 124mA, Rx:44mA</li> <li>Sleep Mode: 26uA</li> </ul>
<b>Software</b>	<ul style="list-style-type: none"> <li>Support open source code</li> <li>Enhanced AT commands</li> <li>Driver support for Windows</li> </ul>
<b>Working Environment</b>	<ul style="list-style-type: none"> <li>Outdoor</li> </ul>
<b>Physical Dimension</b>	<ul style="list-style-type: none"> <li>Dimension (L x W x H): 74mm x 50mm x 24.5mm</li> <li>Weight: Approximately 83.7g(2.95oz)</li> </ul>
<b>Temperature Range</b>	<ul style="list-style-type: none"> <li>Operation Temperature: -10° C ~ +60° C</li> <li>Extended Temperature: -10° C ~ +80° C</li> <li>Storage Temperature: -10° C ~ +80° C</li> </ul>

## Order Information

Part Number	Package	Description
RAK7200-03	1x RAK7200 device, 1x USB cable	LoRa Tracker device, EU868
RAK7200-04	1x RAK7200 device, 1x USB cable	LoRa Tracker device, US915 / AU915
RAK7200-05	1x RAK7200 device, 1x USB cable	LoRa Tracker device, KR920
RAK7200-06	1x RAK7200 device, 1x USB cable	LoRa Tracker device, AS923
RAK7200-07	1x RAK7200 device, 1x USB cable	LoRa Tracker device, IN865



### About RAKwireless:

RAKwireless is the pioneer in providing innovative and diverse cellular and LoRa connectivity solutions for IoT edge devices. It's easy and modular designs can be used in different IoT applications and accelerate time-to-market. For more information, visit RAKwireless website at [www.rakwireless.com](http://www.rakwireless.com).

Copyright © 2019 Shenzhen RAKwireless Technology Co. Ltd. All rights reserved. RAKwireless, RAK logo, and WisKey™ logo are registered trademarks of Shenzhen RAKwireless Technology Co. Ltd. All other trademarks are the property of their respective owners.

Specifications for

# LoRa Tracker Device RAK7200

Version V1.2 | August 2019



[www.RAKwireless.com](http://www.RAKwireless.com)

*Visit our website for more documents.*

12 PAGES





# Table of Contents

<b>1 Overview.....</b>	<b>4</b>
1.1 Introduction.....	4
1.2 Main Features.....	4
<b>2 LoRa Tracker Device RAK7200.....</b>	<b>5</b>
2.1 Overview.....	5
2.2 Block Diagram.....	5
2.3 Interfaces.....	6
2.4 LEDs.....	6
2.5 Operating Frequencies.....	7
2.6 Working Mode.....	7
2.7 Power Requirements.....	8
2.8 Environmental Requirements.....	8
<b>3 Built-in Antenna.....</b>	<b>9</b>
3.1 GPS Antenna.....	9
3.2 LoRa Antenna.....	10
<b>4 Contact Information.....</b>	<b>11</b>
<b>5 Revision History.....</b>	<b>12</b>
<b>6 Document Summary.....</b>	<b>12</b>

## List of Tables

Table 1   Operating Frequencies.....	7
Table 2   Power consumption.....	7
Table 3   Electrical Characteristics.....	8
Table 4   GPS Antenna Parameters.....	9
Table 5   LoRa Antenna Gain.....	10

## List of Figures

Figure 1   RAK7200 OverView.....	5
Figure 2   Block Diagram.....	5
Figure 3   Interfaces.....	6
Figure 4   LEDs.....	7
Figure 5   Built-in Battery.....	8
Figure 6   GPS Antenna.....	9
Figure 7   GPS Antenna S-parameter.....	10
Figure 8   LoRa Antenna.....	10
Figure 9   LoRa Antenna performance.....	10

# 1 Overview

## 1.1 Introduction

The RAK7200 is a GPS tracker with LoRaWAN functionality. It comes with an Li-Ion battery inside the casing, and a convenient rubber belt for quick mounting.

It is built around the low power LoRa module, which integrates an ultra-low power STM32L073 microcontroller and an SX1276 LoRa long range modem. Additionally, there is the Sony CXD5603GF GPS radio on board.

This LoRa node is perfect for IoT applications such as asset tracking, smart vehicle management and location-based services. You need only flash the latest firmware and do a quick configuration setup via the AT commands in order to make it a part of your LoRaWAN network. With the RAK7200 you get a fully functioning GPS tracker, with low power consumption and the great range that LoRa provides.

## 1.2 Main Features

The main features are listed below:

- Built-in digital output motion sensor LIS3DH, which has dynamic user selectable full scales of  $\pm 2g/\pm 4g/\pm 8g/\pm 18g$  and it is capable of measuring accelerations with output data rates from 1Hz to 5kHz.
- Integrated 9-axis sensor - includes a triple-axis gyroscope, a triple-axis accelerometer, and a triple-axis magnetometer.
- LoRaWAN 1.0.2 protocol stack – OTAA and ABP modes.
- LoRa and GPS antennas are integrated inside the casing.
- Low-power mode cycling.
- Micro USB – configuration and battery charging.
- LoRa Bands: EU868, US915, AS923, AU915, KR920, IN865.

## 2 LoRa Tracker Device RAK7200

### 2.1 Overview

The picture below shows the external dimensions of the RAK7200 tracker device.



Figure 1 | RAK7200 OverView

### 2.2 Block Diagram

The block diagram below shows the internal architecture and external interfaces of the RAK7200 tracker device.

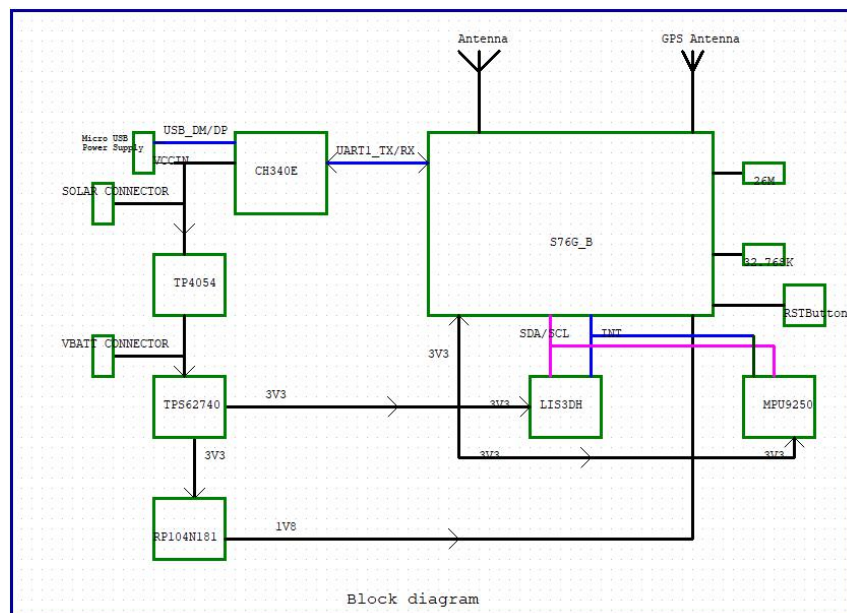

Figure 2 | Block Diagram

## 2.3 Interfaces

The RAK7200 device provides three external interfaces, as shown in the following figure.



Figure 3 | Interfaces

- **Micro USB**  
5V DC power supply and UART communication.
- **Reset Button**  
Reset Button is used to reset the RAK7200 device. Press the Reset Button for more than 1 second, then the device will be reset.
- **BOOT0 Button**  
When upgrade the firmware, you need press and hold the BOOT0 Button, and then press the reset button meanwhile to enter the boot mode.

## 2.4 LEDs

The device provides three LEDs for indicating the operating status, here are their functions:

**LED1 STATUS** – indicates the Li-ion Battery is charging.

**LED2 STATUS** – indicates the Li-ion Battery is full charge.

**LED3 STATUS** – indicates the device is sending data.





Figure 4 | LEDs

## 2.5 Operating Frequencies

The device supports all LoRaWAN frequency bands as below. Which is easy to configure while building the firmware from the source code.

Region	Frequency ( MHz )
Europe	EU868
North America	US915
Asia	AS923
Australia	AU915
Korea	KR920
Indian	IN865

Table 1 | Operating Frequencies

## 2.6 Working Mode

Mode	Power consumption	
Sleep mode	26uA	
Normal mode	Tx @20dB	124mA
	Tx @17dB	108mA
	Tx @13dB	89mA
	Tx @10dB	79mA
	Tx @7dB	69mA
	Rx	44mA

Table 2 | Power consumption

## 2.7 Power Requirements

The RAK7200 tracker device is built-in a rechargeable 3.7V Li-ion battery which can be charged via MicroUSB, the built-in battery is shown in the following figure.



Figure 5 | Built-in Battery

## 2.8 Environmental Requirements

The table below lists the operation and storage temperature requirements.

Parameter	Min.	Typical	Max.
Operation Temp. Range	-10 °C	+25 °C	+60 °C
Extended Temp. Range	-10 °C		+80 °C
Storage Temp. Range	-10 °C		+80 °C

Table 3 | Electrical Characteristics

### 3 Built-in Antenna

The RAK7200 has a built-in passive GPS Antenna and an ipex LoRa Antenna. The performance and parameters of the Antenna are as follows.

#### 3.1 GPS Antenna

The GPS Antenna is shown in the following figure.

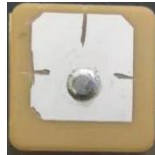

Figure 6 | GPS Antenna

The table below lists the parameters of the built-in GPS Antenna.

Items	Parameter
Outline Dimension	15×15×4mm
Frequency	1575.42MHz
Return Loss	≤ -10
Polarization	RHCP
Gain @Zenith	≥ -4dBi

Table 4 | GPS Antenna Parameters

S-parameter of the GPS Antenna as below.

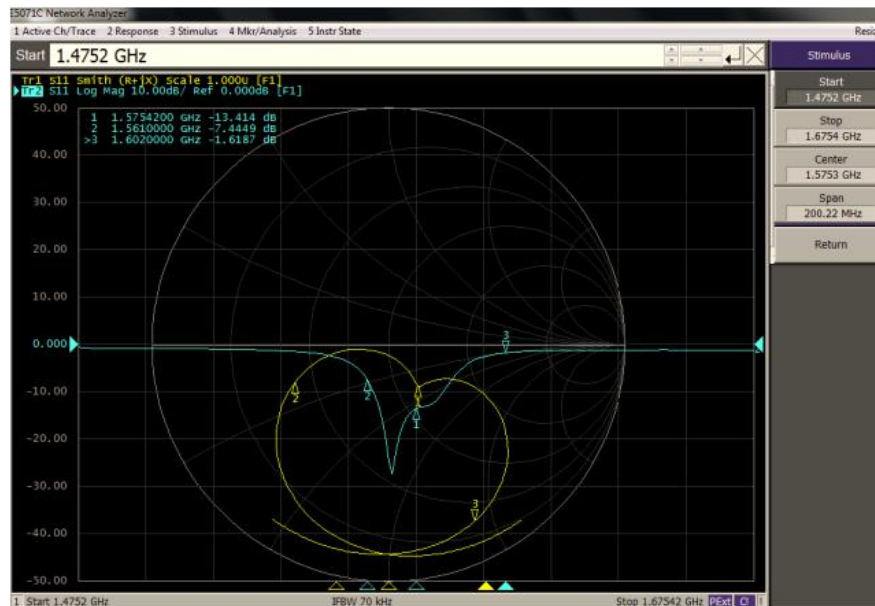

Figure 7 | GPS Antenna S-parameter

### 3.2 LoRa Antenna

The LoRa Antenna is shown in the following figure.



Figure 8 | LoRa Antenna

The table below lists the Efficiency/Gain of the built-in LoRa Antenna.

<b>Freq</b>	863M	928M
<b>EFF</b>	37.40%	40.40%
<b>Gain(dBi)</b>	0.23	1.25

Table 5 | LoRa Antenna Gain

LoRa Antenna return loss as shown below.



Figure 9 | LoRa Antenna performance

## 4 Contact Information

### Shenzhen

 [info@rakwireless.com](mailto:info@rakwireless.com)

 Room 506, Bldg. 3, Minqi Technology Park, No.65 Taoyuan Road,  
Xili Block, Nanshan District, Shenzhen

## 5 Revision History

Revision	Description	Date
1.0	Initial version	2019-02-26
1.1	Remove AT commands chapter	2019-03-25
1.2	Modify main feature content	2019-08-19

## 6 Document Summary

Prepared by	Checked by	Approved by
Hairui & Penn	Hairui	



### About RAKwireless:

RAKwireless is the pioneer in providing innovative and diverse cellular and LoRa connectivity solutions for IoT edge devices. It's easy and modular design can be used in different IoT applications and accelerate time-to-market.

For more information, please visit RAKwireless website at [www.rakwireless.com](http://www.rakwireless.com).