

Features

- 15.6" New Generation Stainless Steel Display
- True Flat Front Bezel Design and Grade 304 Stainless Steel Enclosure (Grade 316 for Option)
- IP66/IP69K Rated with M12 Connectors
- Support Resistive Touch, Projected Capacitive Touch, and Glass
- Touch on/off Button on the Side Edge for Hygienic Cleaning
- Support Ergonomic Versatile Mounting: Yoke Mounting / Space-saving VESA 75 x 75 mm Mounting

Specifications

IO Port	
VGA	1 x M12 12-pin for VGA with waterproof cover and chain
HDMI	1 x M12 HDMI with waterproof cover and chain
Speaker	1 x 2W IP65 speaker (option)
OSD Control Membrane	OSD on the rear side
Power Connector	1 x M12 3-pin for DC power with waterproof cover and chain

Display	Standard	High Brightness Optional
Display Type	15.6" TFT-LCD	15.6" TFT-LCD
Max. Resolution	1366 x 768	1366 x 768
Max. Color	16.7M	16.7M
Luminance (cd/m ²)	350	1000
View Angle	160(H) /160(V)	160(H) /160(V)
Contrast	500:1	500:1
Backlight Lifetime	50,000 hrs	50,000 hrs
Option	Optical Bonding	Optical Bonding

Touch Screen	
Type	Resistive Touch (For R model) Projected Capacitive Touch (For P model) Glass (For G model)
Interface	USB
Light Transmission(%)	Resistive Touch : 80% / Projected Capacitive : 90%

Power	
Power Input	DC 9~36V
Power Consumption	ViTAM-116P: 12.3W ViTAM-116PH: 15W

Mechanical	
Construction	304 Stainless steel chassis(default), 316 Stainless steel chassis(optional)
Mounting	VESA Mount 75 x 75, Yoke mount (option)
IP Rating	Total IP66/IP69K
Dimensions	440 x 290 x 55 mm
Net Weight	6.4 kg

Dimensions

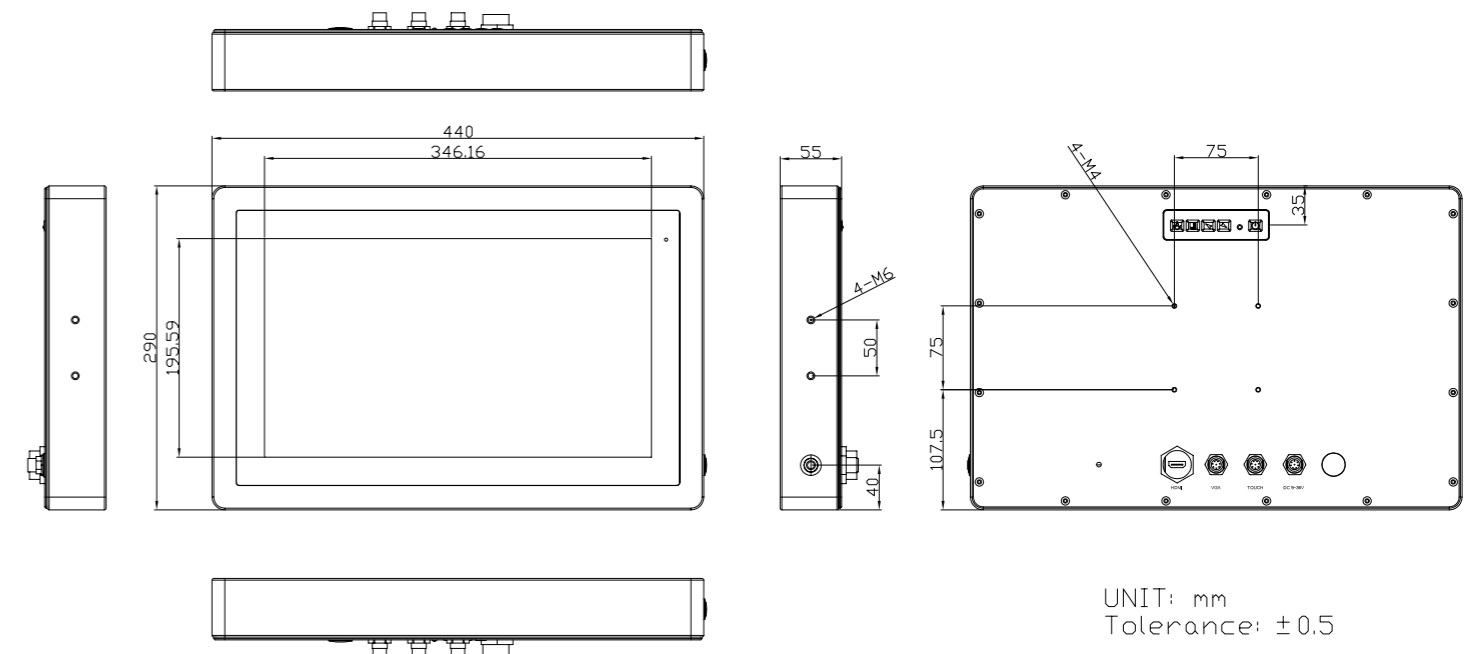

Environmental	
Operating Temperature	0~50°C
Storage Temperature	-30~70°C
Storage Humidity	10 to 90% @ 40°C, non- condensing
Certificate	CE/FCC Class A

Ordering Information	
ViTAM-116P	15.6" WXGA IP66/IP69K stainless steel display, VGA/HDMI input, OSD on the rear side, projected capacitive touch, 9~36V DC power input with Adapter
ViTAM-116R	15.6" WXGA IP66/IP69K stainless steel display, VGA/HDMI input, OSD on the rear side, 5 wire resistive touch window, 9~36V DC power input with Adapter
ViTAM-116G	15.6" WXGA IP66/IP69K stainless steel display, VGA/HDMI input, OSD on the rear side, protection glass, 9~36V DC power input with Adapter
ViTAM-116PH	15.6" WXGA IP66/IP69K stainless steel display, VGA/HDMI input, OSD on the rear side, projected capacitive touch, 9~36V DC power input with Adapter, 1,000 nits LCD
ViTAM-116RH	15.6" WXGA IP66/IP69K stainless steel display, VGA/HDMI input, OSD on the rear side, 5 wire resistive touch window, 9~36V DC power input with Adapter, 1,000 nits LCD
ViTAM-116GH	15.6" WXGA IP66/IP69K stainless steel display, VGA/HDMI input, OSD on the rear side, protection glass, 9~36V DC power input with Adapter, 1,000 nits LCD