

# FMC172

## Wideband Low Latency FMC Module

The FMC172 is an analog-to-digital (A/D) and digital-to-analog (D/A) FMC daughter card that provides one 10-bit A/D channel at 6.4 GSPS and one 10-bit D/A channel at 6 GSPS. The sample clock is supplied internally and is locked to either internal or external reference. A trigger input is also available for customized sampling control and to enable synchronization across multiple cards.

The FMC172 is mechanically and electrically compliant to the FMC standard (ANSI/VITA 57.1). It can be used in a conduction-cooled environment with Abaco carrier cards.

The FMC172 utilizes LVDS connectivity to the host carrier, to enable latency from the RF to RF connector under 20ns. Coupled with >6GHz of instantaneous bandwidth in both transmit and receive, the FMC172 is ideal for

ultra low latency applications. The analog signal input and output are AC-coupled and connected to SSMC coax connectors on the front panel.

The FMC172 allows flexible control of sampling frequency, and calibration through I2C communication. The ADC has individual calibration circuits for fine-tuning of gain, offset, and phase.

The card is equipped with power supply and temperature monitoring and offers several power-down modes to switch off unused functions or protect the card from overheating.

The FMC172 is ideal for applications where low latency high bandwidth sampling are the driving requirements such as DRFMs.

### FEATURES:

- Single-channel, 10-bit A/D up to 6.4GSPS
- Single-channel, 10-bit D/A up to 6.0GSPS
- VITA 57.1 FMC compliant
- Conduction-cooled version available (Deviation from Standard)
- AC-coupled analog signals
- 5 SSMC front panel connectors
- Sampling frequency and calibration through I2C communication
- Flexible clock tree enables:
  - Internal clock source
  - External reference clock
- Trigger signal to enable multi-board synchronization
- Power-down modes to switch off unused functions for system power savings
- MIL-I-46058c Conformal Coating compliant (optional)

# FMC172 Wideband Low Latency FMC Module

## Specifications

### Application:

- Software Defined Radio
- Direct RF Down Conversion
- Radar/Sonar Electronic Warfare
- Direction Finding
- Ultra-Wideband Satellite Digital Receiver and Transmitter
- Wireless communication transceivers and base stations
- Medical equipment
- Aerospace and test & measurement instruments support

### Support:

- StellerIP is available for this product. It provides a simple way to design FPGA firmware with automated code.
- This module can be used on any FMC/ FMC+ compatible carrier card in air-cooled and some conduction-cooled carriers
- User manual
- Performance report
- Support provided on Abaco Systems support forum private boards
- Reference designs available for FPGA carriers

## Block diagram

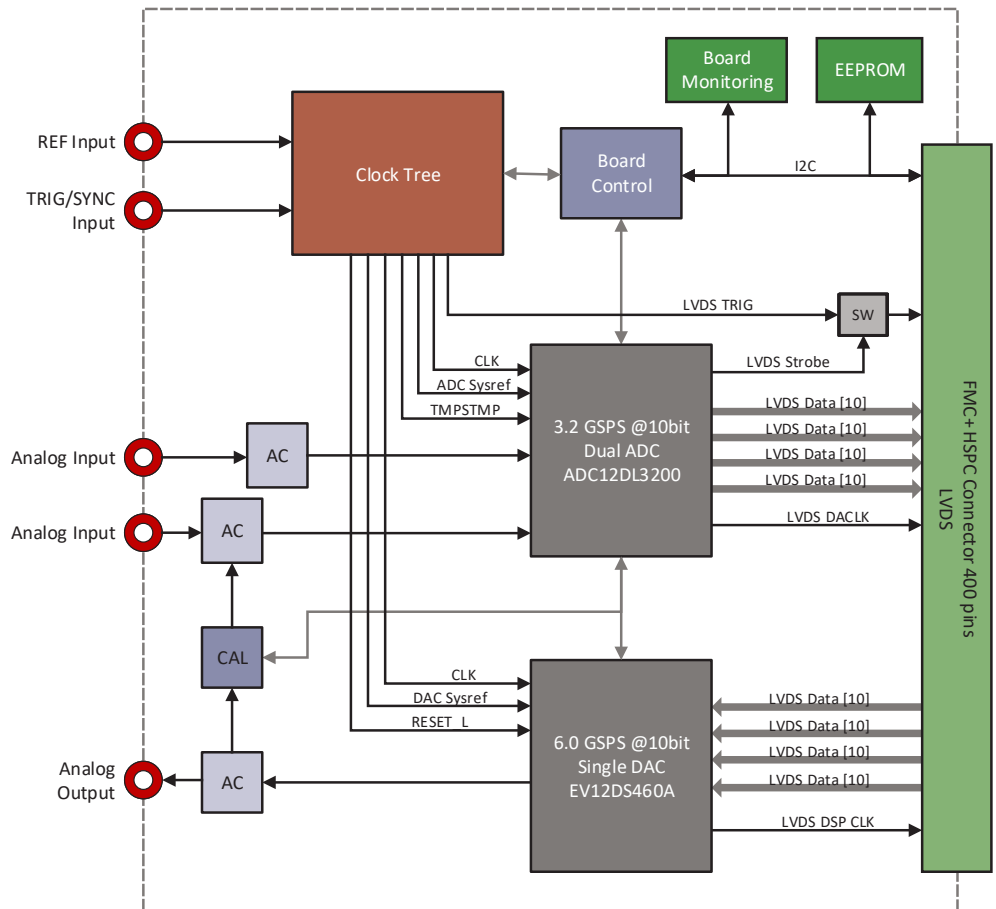

WE INNOVATE. WE DELIVER. YOU SUCCEED.

Americas: 866-OK-ABACO or +1-866-652-2226 Asia & Oceania: +81-3-5544-3973

Europe, Africa, & Middle East: +44 (0) 1327-359444

Locate an Abaco Systems Sales Representative visit: [abaco.com/products/sales](http://abaco.com/products/sales)

[abaco.com](http://abaco.com) | @AbacoSys

©2019 Abaco Systems. All Rights Reserved. All other brands, names or trademarks are property of their respective owners. Specifications are subject to change without notice.

