

# G22

## Intel Core i7 CPU Board 3U CompactPCI Serial

- » Intel Core i7, 3rd generation
- » Quad-core 64-bit processor
- » 4 HP system master and peripheral slot
- » PICMG CPCI-S.0 CompactPCI Serial
- » 4 or 8 GB DDR3 DRAM soldered, ECC
- » mSATA and microSD card slots
- » Standard front I/O: 2 DisplayPorts, 2 Gb Ethernet, 2USB 2.0
- » Standard rear I/O: 7 PCIe, 4 USB 2.0, 4 USB 3.0, 5 SATA, DisplayPort/HDMI
- » Rear I/O via mezzanine board: up to 8 Gigabit Ethernet
- » Intel Turbo Boost, Hyper-Threading, AMT 8.0
- » Open CL support

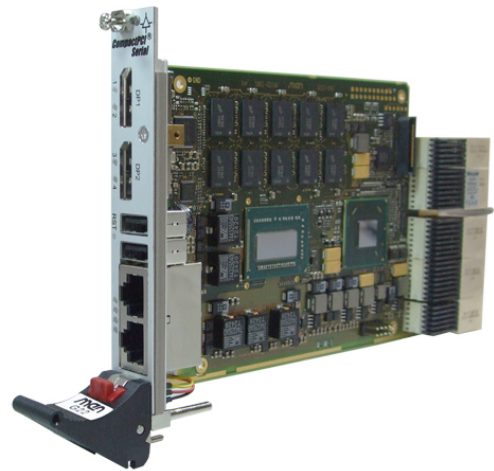

The G22 is a versatile 4HP/3U single-board computer supporting a multitude of modern serial interfaces according to the CompactPCI Serial standard. It is thus perfectly suited for data-intensive applications which require high computing-power. The CPU card is equipped with the Intel third-generation Core i7 processor running at up to 3.3 GHz maximum turbo frequency and offering the latest multi-core processor architecture from Intel with full 64-bit support. The processor frequency can be stepped down via the BIOS to lower power consumption and make the board more suitable for high temperatures. The G22 supports the Intel Active Management technology which makes it possible to access the board via the network even when it is in soft-off or standby state.

For system security, a Trusted Platform Module is available on request.

The memory configuration of the G22 includes a state-of-the-art fast DDR3 DRAM which is soldered to the board to guarantee optimum shock and vibration resistance. An mSATA disk connected via a SATA channel and a microSD card device which is connected via a USB interface offer

nearly unlimited space for user applications.

The board delivers an excellent graphics performance. Two DisplayPort interfaces are accessible at the board front. Using an external adapter two HDMI or two DVI ports can also be realized. The standard front I/O comprises two PCIe-driven Gigabit Ethernet and two USB 2.0 ports.

Serial interfaces at the rear I/O connectors are 4 USB 2.0, 4 USB 3.0, 5SATA interfaces, one DisplayPort or HDMI, 5 PCI Express x1 links, and two PEG x8 links. Up to eight Gigabit Ethernet interfaces can be implemented using a rear I/O adapter board.

A board management controller provides thermal supervision of the processor and a watchdog for the operating system.

The G22 operates in Windows and Linux environments as well as under real-time operating systems that support Intel's multi-core architecture.

The G22 comes with a tailored passive heat sink. All components are soldered for protection against shock and vibration according to applicable DIN, EN or IEC industrystandards. Optionally, the board comes with an M12 Ethernet connector. The G22 is ready for coating so that it can be used in humid and dusty environments and has a guaranteed minimum standard availability of 7 years.

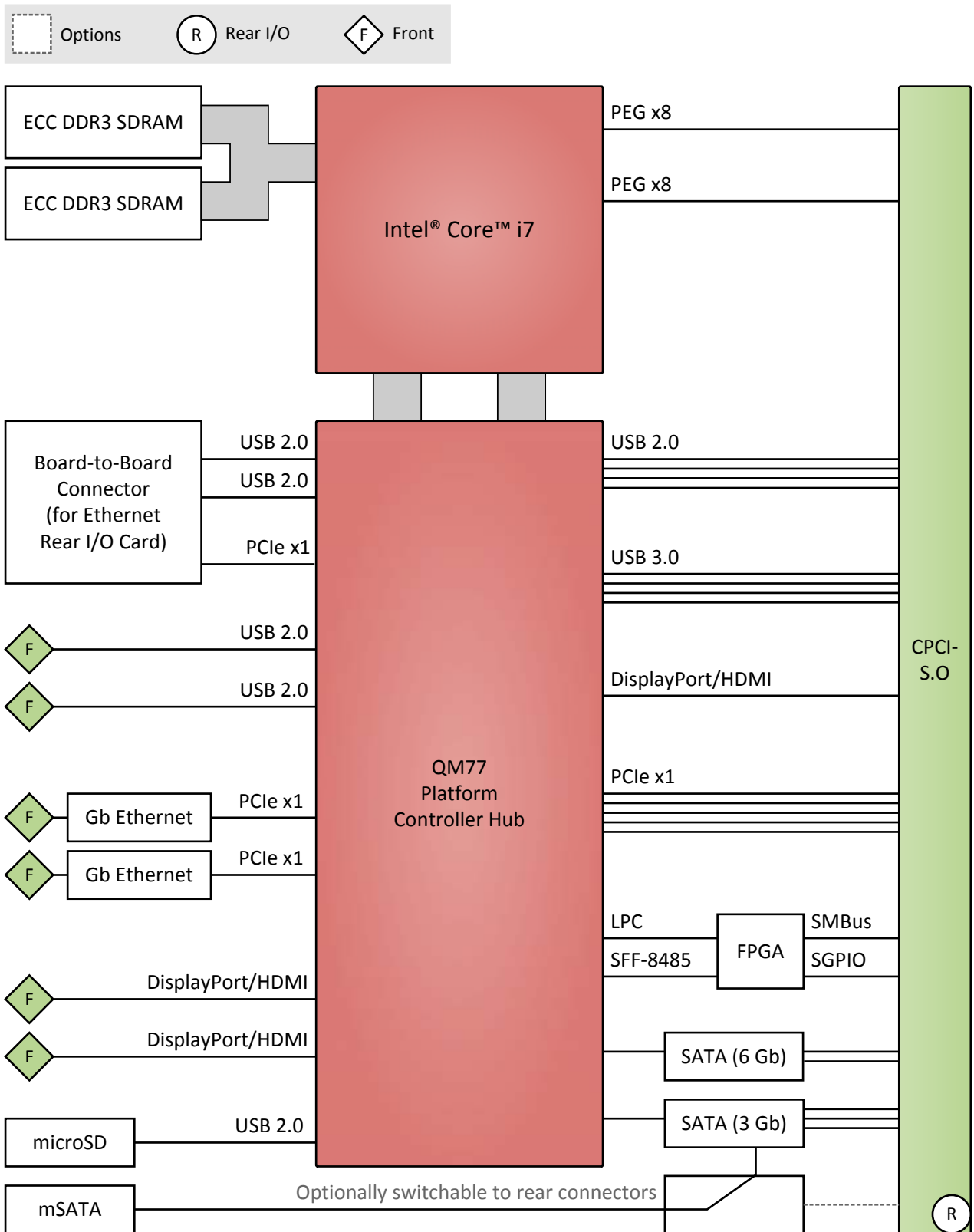

## CPU

- Intel Core i7-3615QE
  - 2.3 GHz processor core frequency
  - 3.3 GHz maximum turbo frequency
  - 1066 MHz system bus frequency
- Chipset
  - QM77 Platform Controller Hub (PCH)

## Board Management Controller

- Power supervision and watchdog
- Temperature measurement
- 2 board status LEDs
- 2 user LEDs
- Reset button

## Memory

- 6 MB last level cache integrated in i7 processor
- Up to 8 GB SDRAM system memory
  - Soldered
  - DDR3 with ECC support
  - Up to 1066 MHz memory bus frequency
- 64 Mbits boot Flash
- Serial EEPROM 2 KB for factory settings
- mSATA disk slot
  - Connected via one SATA port from the PCH
- Serial GPIO (SGPIO)
  - One interface via CPCI-S.0 rear connector
  - Compliant with SFF 8485 specification
- One microSD card slot
  - Via USB

## Mass Storage

- Serial ATA (SATA)
  - Five channels via rear I/O (six if the link to the mSATA disk is not required, can be switched in BIOS)
  - Four ports with transfer rates up to 3 Gbit/s (SATA Revision 2.x)
  - Two ports with transfer rates up to 6 Gbit/s (SATA Revision 3.x)
  - RAID level 0/1/5/10 support
  - Hot-plug together with G501

## Graphics

- Integrated in QM77 chipset
  - Maximum resolution: up to 2560x1600
- Two DisplayPort connectors at front panel
  - Optionally two DVI/HDMI ports via external adapter
- One DisplayPort at CPCI-S.0 rear connector
  - Optionally SDVO or DVI/HDMI port

**I/O**

- USB 2.0
  - Two USB 2.0 host ports via Type A connector at front panel
  - Up to eight USB 2.0 host ports via CPCI-S.0 rear connector (depending on the number of used USB 3.0 ports)
  - Two USB 2.0 host ports for connection of the rear I/O card
  - EHCI implementation
  - Data rates up to 480 Mbit/s
- USB 3.0
  - Four USB 3.0 host ports via CPCI-S.0 rear connector
  - Data rate up to 5 Gbit/s
- Ethernet
  - Two 10/100/1000Base-T Ethernet channels at the front
  - RJ45 connectors at front panel
  - Ethernet controllers are connected by two x1 PCIe links
  - Two onboard LEDs to signal LAN link, activity status and connection speed

**Front Connections**

- Two DisplayPort
- Two USB 2.0 (Type A)
- Two Ethernet (RJ45)

**Rear I/O**

- 5 SATA (6 switchable in BIOS)
- 1 DisplayPort
- 4 USB 2.0
- 4 USB 3.0
- 5 PCI Express x1 links
- 2 PEG x8 links
- SGPIO

**PCI Express**

- Two x8 PCI Express graphics links via CPCI-S.0 rear connector
  - Data rate 985 MB/s (8 Gbit/s per lane)
- Five x1 PCIe links via CPCI-S.0 rear connector
  - Data rate 500 MB/s (5 Gbit/s per lane)
- Two x1 PCIe links to connect local 1000Base-T Ethernet controllers
  - Data rate 250 MB/s (2.5 Gbit/s per lane)
- One x1 PCIe link via for connection of the rear I/O card
  - Data rate 500 MB/s (5 Gbit/s per lane)

**Miscellaneous**

- Real-time clock with supercapacitor backup, battery-buffered

**CompactPCI Serial**

- Compliance with CompactPCI Serial PICMG CPCI-S.0 Specification
- System or peripheral slot

**Electrical Specifications**

- Supply voltage/power consumption:
  - +12V (9..16V), 4 A nominal, 5.8 A maximum
  - +5V (-5%/+5%) standby voltage optional

**Mechanical Specifications**

- Dimensions: conforming to CompactPCI Serial specification for 3U boards
- Front panel: 4HP with ejector
- Weight:
  - 208 g (w/o heat sink)
  - 398 g (with heat sink and mSATA adapter)

## Environmental Specifications

- Temperature range (operation):
  - Depends on system configuration (CPU, hard disk, heat sink...)
  - Maximum: +85°C
  - Minimum: -40°C (all processors)
  - Airflow: min. 1.5 m/s, typical power dissipation tbd, with Windows XP operating system, 1 Gb Ethernet, without CPU clock reduction
- Temperature range (storage): -40..+85°C
- Relative humidity (operation): max. 95% non-condensing
- Relative humidity (storage): max. 95% non-condensing
- Altitude: -300 m to + 3,000 m
- Shock: 50 m/s<sup>2</sup>, 30 ms
- Vibration (function): 1 m/s<sup>2</sup>, 5 Hz - 150 Hz
- Vibration (lifetime): 7.9 m/s<sup>2</sup>, 5 Hz - 150 Hz
- Conformal coating on request

## MTBF

- 455,629 h @ 40°C according to IEC/TR 62380 (RDF 2000)

## Safety

- Flammability (PCBs)
  - PCB manufactured with a flammability rating of 94V-0 by UL recognized manufacturers
- Electrical Safety
  - Insulation measurement test according to EN 50155 (12.2.9.1)
  - Voltage withstand test according to EN 50155 (12.2.9.2)
  - Information technology equipment test according to EN 60950

## EMC Conformity

- EN 55022 (radio disturbance)
- IEC 61000-4-2 (ESD)
- IEC 61000-4-3 (electromagnetic field immunity)
- IEC 61000-4-4 (burst)
- IEC 61000-4-5 (surge)
- IEC 61000-4-6 (conducted disturbances)

## BIOS

- InsydeH2O UEFI Framework

## Intel Active Management Technology

- Out of Band (OOB) Access
  - Power off Access
  - Independent of OS status
  - Power status control
  - Keyboard-Video-Mouse (KVM) Viewer (VNC-compatible)
  - IDE-Redirect
  - Serial-over-LAN
- Manageability Engine in Chipset
- Network Filters in Chipset
- Dedicated Flash Storage Area

## Software Support

- Windows
- Linux
- VxWorks (on request)
- QNX
- For more information on supported operating system versions and drivers see Software.

## Options

### **CPU**

- Intel Core i7
- Intel Core i5
- Intel Core i3
- Intel Celeron
- For more details please see the overview matrix of supported processor types

### **Memory**

- System RAM
  - 2 GB, 4 GB, 8 GB or 16 GB (16 GB when components available)
- mSATA disk
  - 0 MB up to maximum available
- microSD card
  - 0 MB up to maximum available

### **I/O**

- Ethernet
  - One Gigabit Ethernet on M12 connector instead of two interfaces on RJ45

### **Rear I/O**

- PCI Express
  - 8 PCI Express lanes
- Ethernet
  - Up to eight Gigabit Ethernet interfaces on the backplane using rear I/O card (e.g. GM1)

### **Operating Temperature**

- Depends on system configuration (CPU, hard disk, heat sink...)
- Maximum: +85°C
- Minimum: -50°C

### **Cooling Concept**

- Also available with conduction cooling in MEN CCA frame

**Some of these options may only be available for large volumes.**

- Please ask our sales staff for more information.

## Germany

### **MEN Mikro Elektronik GmbH**

Neuwieder Straße 3-7  
90411 Nuremberg  
Phone +49-911-99 33 5-0

sales@men.de  
[www.men.de](http://www.men.de)

## USA

### **MEN Micro Inc.**

860 Penllyn Blue Bell Pike  
Blue Bell, PA 19422  
Phone 215-542-9575

sales@menmicro.com  
[www.menmicro.com](http://www.menmicro.com)

## France

### **MEN Mikro Elektronik SAS**

18, rue René Cassin  
ZA de la Châtelaine  
74240 Gaillard  
Phone +33-450-955-312

sales@men-france.fr  
[www.men-france.fr](http://www.men-france.fr)

## China

### **MEN Mikro Elektronik (Shanghai) Co., Ltd.**

Room 808-809, Jiaxing Mansion, No. 877 Dongfang Road  
200122 Shanghai  
Phone +86-21-5058-0961

sales@men-china.cn  
[www.men-china.cn](http://www.men-china.cn)

### **Up-to-date information, documentation and ordering information:**

[www.men.de/products/g22/](http://www.men.de/products/g22/)

*The date of issue stated in this data sheet refers to the Technical Data only. Changes in ordering information given herein do not affect the date of issue. All brand or product names are trademarks or registered trademarks of their respective holders.*

*MEN is not responsible for the results of any actions taken on the basis of information in the publication, nor for any error in or omission from the publication.*

*MEN expressly disclaims all and any liability and responsibility to any person, whether a reader of the publication or not, in respect of anything, and of the consequences of anything, done or omitted to be done by any such person in reliance, whether wholly or partially, on the whole or any part of the contents of the publication.*

*The correct function of MEN products in mission-critical and life-critical applications is limited to the environmental specification given for each product in the technical user manual. The correct function of MEN products under extended environmental conditions is limited to the individual requirement specification and subsequent validation documents for each product for the applicable use case and has to be agreed upon in writing by MEN and the customer. Should the customer purchase or use MEN products for any unintended or unauthorized application, the customer shall indemnify and hold MEN and its officers, employees, subsidiaries, affiliates, and distributors harmless against all claims, costs, damages, and expenses, and reasonable attorney fees arising out of, directly or indirectly, any claim or personal injury or death associated with such unintended or unauthorized use, even if such claim alleges that MEN was negligent regarding the design or manufacture of the part.*

*In no case is MEN liable for the correct function of the technical installation where MEN products are a part of.*

© 2017 MEN Holding